

GLD-LED-100W

Crestron Green Light® 100W Dimmable LED Drivers

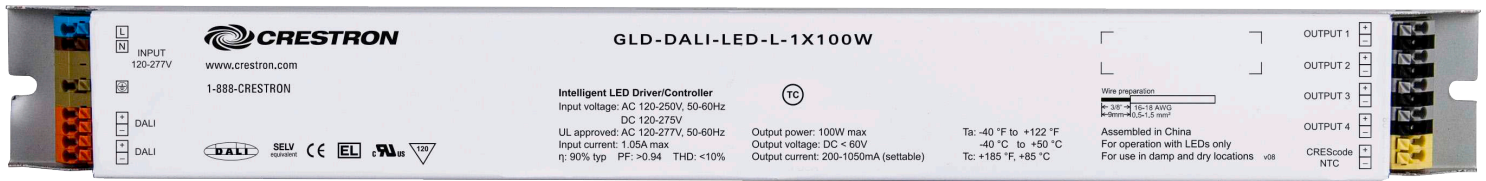

- > Programmable, dimmable, high-power LED drivers
- > DALI® or 0-10V controllable
- > Superior, smooth dimming to below 1%
- > Excellent color stability, even at low dimming levels
- > Linear or logarithmic dimming curve
- > High efficiency over a wide power and voltage range
- > CREScode™ programmable for use with a wide variety of LED fixtures
- > Lowers costs by reducing inventory requirements
- > Multiple outputs with independent LED current settings
- > 2-channel models support tunable white lighting and direct-indirect fixtures
- > NTC interface for robust thermal management
- > Available in long or short case form factors
- > Compatible with 120V, 230V, and 277V AC systems
- > 100W power rating (50W also available)

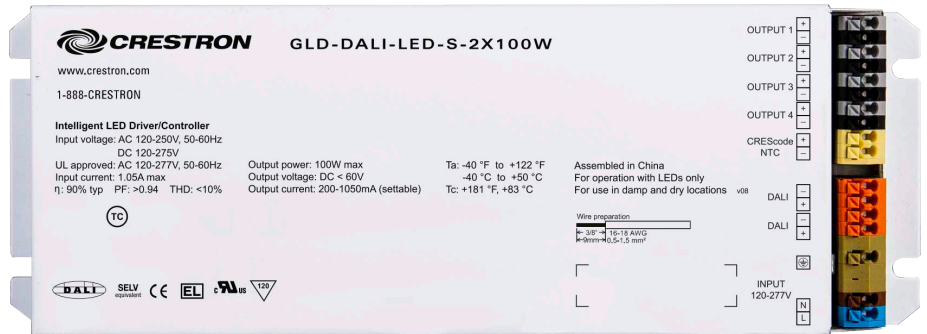

Multiple Outputs

To support a wider variety of fixture configurations, Crestron Green Light LED drivers include multiple LED outputs. The outputs are controlled as one, however the output current for each can be set separately by the fixture manufacturer. The single-channel 100W models provide four outputs, while the 2-channel 100W models provide two outputs per channel.

DALI® Lighting Control

DALI (Digital Addressable Lighting Interface) is a lighting control protocol that allows multiple lighting fixtures to be networked using a single daisy-chained control wire. Up to 64 fixtures can exist on a single DALI channel. DALI provides a bidirectional interface enabling independent control and monitoring of each individual fixture. DALI is optimal for use in applications that require granular control of each fixture, such as open office floor plans, AV-equipped conference rooms, and daylight harvesting. In addition to DALI dimmable LED drivers, Crestron® offers a full line of lighting control products utilizing DALI technology.

0-10V Dimming Control

This simple interface affords essential dimming control using a 0 to 10 Volt DC control signal. Crestron Green Light 0-10V Dimmable LED Drivers afford high-quality, single-channel dimming, and are compatible with both current sink and current source controls.

CREScode™ Programmability

Crestron Green Light Dimmable LED Drivers are programmable using the [CREScode LED Driver Configuration Tool](#), allowing each LED driver to be matched perfectly to its fixture at the factory. The hardware/software utility provides a simple means of selecting the dimming curve and setting the minimum dimming level, NTC temperature and output current. The output current can be set individually for each LED output. The use of programmable LED drivers reduces inventory requirements, allowing a single driver model to be used with numerous different fixtures.

Crestron Green Light® Dimmable LED Drivers (GLD-LED) provide manufacturers of dimmable LED lighting fixtures with a high-performance, cost-saving LED driver solution. Offered in two compact case styles, the GLD-LED series fits easily into a wide range of enclosures and fixture designs. The choice of DALI® or 0-10V control enables compatibility with virtually any lighting control system. All models are operable between 120V and 277V, reducing inventory costs for manufacturers serving multiple regions.

Superior, High-Power Dimming

Employing a combination of duty-cycle and current dimming technologies, Crestron Green Light LED drivers provide smooth, deep dimming with excellent color stability to below 1%. A choice of 50W and 100W models affords high-power capability for use with a wide range of LED fixtures. (Refer to the GLD-LED-50W spec sheet for 50W models.)

2-Channel Option

Models featuring DALI control are available in either single or 2-channel configurations. The 2-channel option provides two independently controllable channels in one housing, offering a cost-saving, space-efficient solution for use with tunable white lighting and fixtures with separate direct and indirect lighting components.

GLD-LED-100W Crestron Green Light® 100W Dimmable LED Drivers

OEM Fixture Partner Program

Crestron works directly with leading global fixture manufacturers to provide complete access to its entire line of ballasts and drivers. Crestron works with each partner to ensure excellence in quality, performance and function to deliver superior dimming, ease of commissioning, and complete control. All Crestron products are backed by our unparalleled training, design assistance, and support services.

To learn more about our OEM Fixture Partners or to become one, please email OEM@crestron.com.

SPECIFICATIONS

Input

Voltage: 120-277 Volts AC
Frequency: 50/60 Hz
Current (100W models): 1.05 Amps maximum @ 120V/60Hz; 0.5 Amp maximum @ 230V/50Hz; 0.45 Amp maximum @ 277V/60Hz

Output

Number of Class 2 LED Outputs: Single-channel 100W models = 4;
2-channel 100W models = 2 per chan.
Number of Dimming Channels: 1 or 2 depending on model
Voltage: 57 Volts typical, 60 Volts maximum
Power: 100 Watts maximum
Current Range: configurable from 200 mA to 1050 mA per output
Current Accuracy: ±5%

Wiring Data

Wire type: solid or stranded copper
Wire strip length: 9mm, 0.35 in.
Wire core cross section: 0.5 - 1.5 mm², AWG 20 - 16
Maximum LED wiring length:

AWG value	20	19	18	17	16
Distance (m)	14	18	22	28	36
Distance (ft)	46	59	72	92	118

Dimming

Type: Constant current
Range: 0-100%
Curve: configurable for linear or logarithmic
Control Interface: DALI® or 0-10V (current sink and current source compatible) depending on model

General

Standby power: <0.5 Watt
Inrush current: 35 Amps 240 µS @ 120V/60Hz; 67 Amps 240 µS @ 230V/50Hz; 75 Amps 240 µS @ 277V/60Hz
Surge protection: 3 kV L to N, 4 kV L/N to ground
Efficiency: 90% at full load, ≥87% above 50 Watt output
Power Factor: >0.94

THD: <10% at full load

Thermal Management: Supports LED temperature feedback using 47k Ohm NTC thermistor (not included)

Configurable Parameters (via CREScode™): Output current (per LED output), dimming curve, minimum dimming level, NTC temperature

Connections

INPUT 120-277V: (1) 3-position pushbutton terminal block for Line, Neutral and Ground
DALI (DALI models only): (2) 2-position pushbutton terminal blocks for interface to DALI bus
0-10V (LV models only): (1) 2-position pushbutton terminal block for 0-10V control input
OUTPUT 1 – 4: (4) 2-position pushbutton terminal blocks for LED outputs
CREScode/NTC: (1) 2-position pushbutton terminal block for interface to CREScode configuration tool during factory setup, and for 47k Ohm NTC thermistor during operation

Note: All terminal blocks accommodate 20 to 16 AWG (0.5 to 1.5 mm²) solid or stranded copper conductors

Environmental

Temperature Range: -40° to 122°F (-40° to 50°C)
Maximum Tc (long case models): 185°F (85°C)
Maximum Tc (short case models): 181°F (83°C)
Life Expectancy: 50,000 hours at or below maximum rated ambient temperature
MTBF: 480,000 hours

Enclosure

Metal, painted

Dimensions

Long Case: Height: 1.61 in (41 mm);
Width: 14.57 in (370 mm);
Depth: 1.18 in (30 mm)
Short Case: Height: 3.15 in (80 mm);
Width: 9.06 in (230 mm);
Depth: 1.18 (30 mm)

Weight

Long Case: 31.1 oz (880 g)
Short Case: 31.1 oz (880 g)

Certifications

CE;
UL: Recognized Component for US and Canada according to UL1310 and UL8750; US: Class 2 output; Canada: Non-Class 2 output; IEC 61347-1, IEC 61347-2-13, IEC 62384 + A1, EN 55015 + A1, EN 55022 + A1, IEC 61000-3-2, IEC 61547 + A1, IEC 62386-101/102/207;
FCC: Title 47CFR Part 15 Class B

GLD-LED-100W Crestron Green Light® 100W Dimmable LED Drivers

MODELS & ACCESSORIES

Available Models

- GLD-DALI-LED-L-1X100W: 100W DALI Dimmable LED Driver, Long Case
- GLD-DALI-LED-S-1X100W: 100W DALI Dimmable LED Driver, Short Case
- GLD-DALI-LED-L-2X100W: 2 Channel 100W DALI Dimmable LED Driver, Long Case
- GLD-DALI-LED-S-2X100W: 2 Channel 100W DALI Dimmable LED Driver, Short Case
- GLD-LV-LED-L-1X100W: 100W 0-10V Dimmable LED Driver, Long Case
- GLD-LV-LED-S-1X100W: 100W 0-10V Dimmable LED Driver, Short Case

Available Accessories

- GLDA-LED-PROG-CRESCODE: CREStoCode™ LED Driver Configuration Tool

Notes:

The specific patents that cover Crestron products are listed online at: patents.crestron.com.

Crestron, the Crestron logo, CREStoCode, and Crestron Green Light are either trademarks or registered trademarks of Crestron Electronics, Inc. in the United States and/or other countries. DALI is either a trademark or registered trademark of ZVEI - Zentralverband Elektrotechnik- und Elektronikindustrie in the United States and/or other countries. Other trademarks, registered trademarks, and trade names may be used in this document to refer to either the entities claiming the marks and names or their products. Crestron disclaims any proprietary interest in the marks and names of others. Crestron is not responsible for errors in typography or photography. Specifications are subject to change without notice. ©2014 Crestron Electronics, Inc.

DIMENSIONAL DIAGRAMS

Long Case

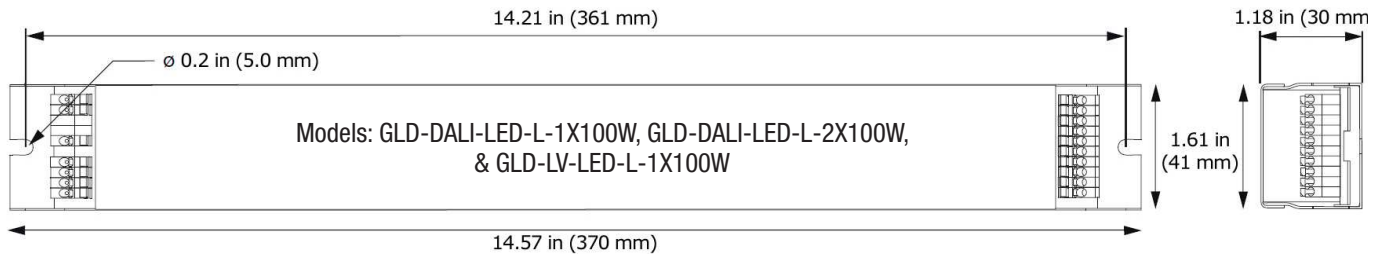

Short Case

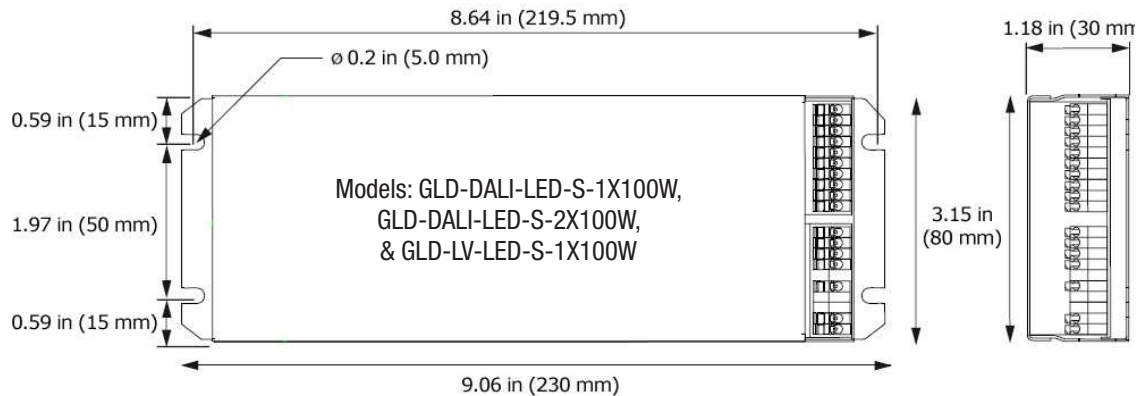

EFFICIENCY DATA

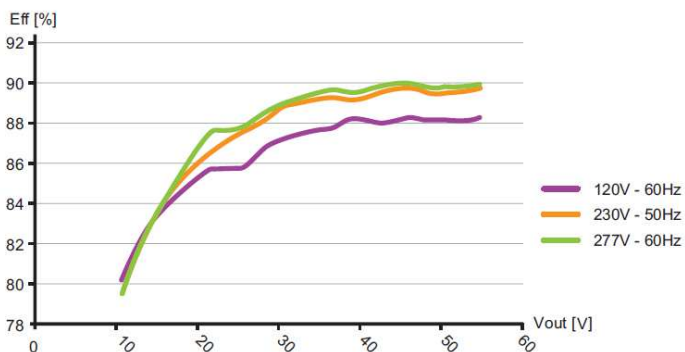

Efficiency vs Vout at Ta 25 °C / 77 °F

POWER FACTOR DATA

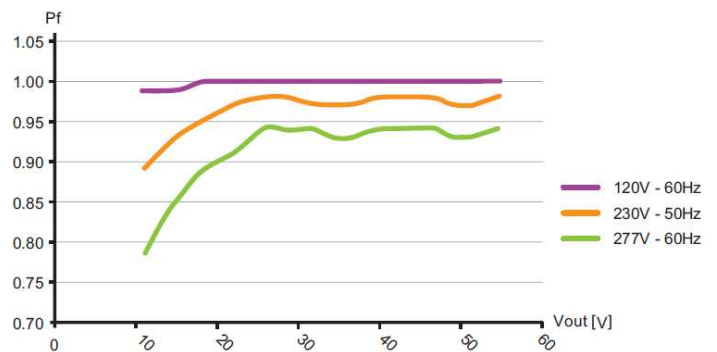

Power factor vs Vout at Ta 25 °C / 77 °F

GLD-LED-100W Crestron Green Light® 100W Dimmable LED Drivers

WIRING DIAGRAMS

DALI

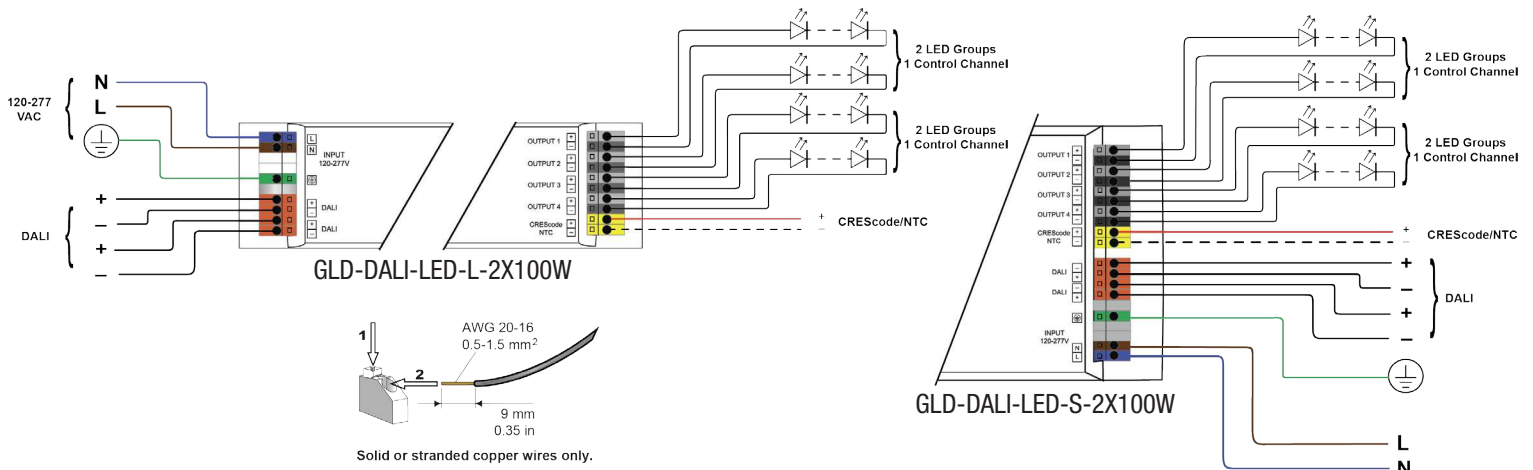
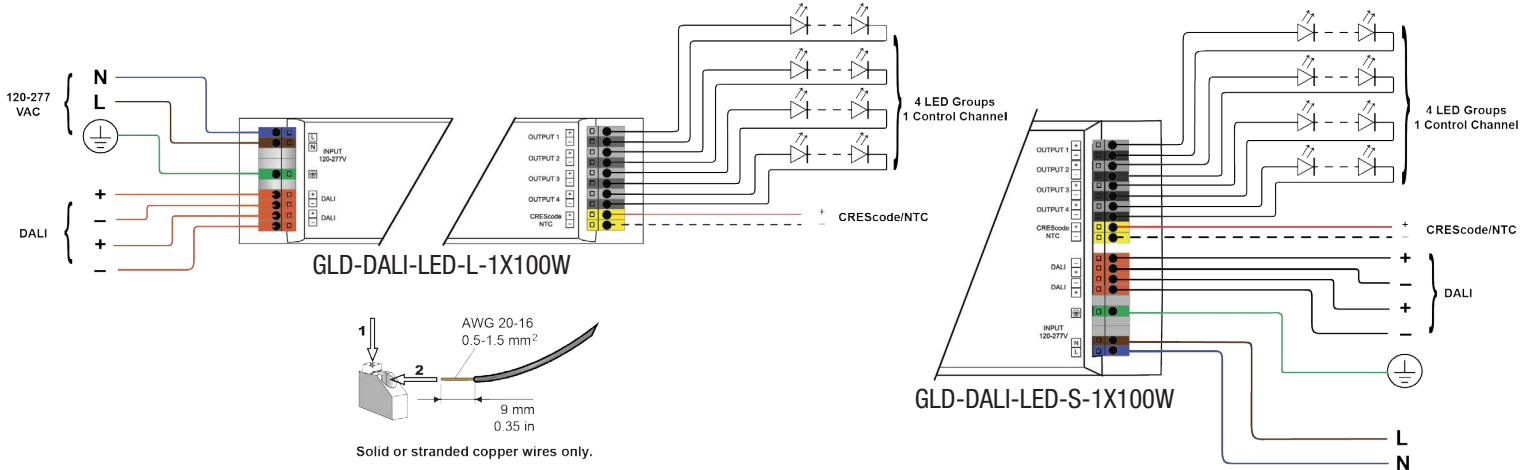

0-10V

