

Crestron® Shading Solutions Architectural Series

- > Quiet operation
- > Smooth, silent starts, and stops
- > Offers programmable stop points. QMT™ tracks the position of the shade and is able to adjust it to predetermined locations at the touch of a button.
- > Provides maximum window coverage with the smallest possible light gaps, 0.75 in (19 mm) between the shade fabric and the window frame. Light gaps are symmetrical on both sides of shade.
- > Easy-to-read and easy-to-use controls are immediately understood
- > Does not require group controls or relay systems to create shade groups and sub-groups
- > 24 V low-voltage power
- > Power failure memory for the lifetime of the product
- > 8 year limited warranty

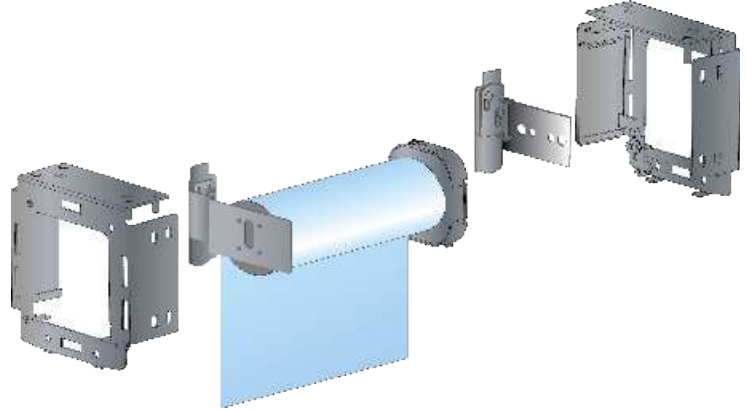

The Crestron Shading Solutions Architectural Series utilizes the quiet, precision controlled Quiet Motor Technology (QMT). The Crestron QMT is housed inside the roller shade assembly and controls the movement of the shade, keeps track of the shade's position, and adjusts the shade to the user's desired preset positions.

SPECIFICATIONS

Power

Operating Voltage: Low Voltage Class 2, 24 V DC (Power Supply required)

Performance

System allows for symmetrical light gaps as small as 0.75 in (19 mm) on each side.

Presets can be created to stop at any point along the shade's travel as well as full open and close limits.

Limits are programmable and adjustable from the motor or Crestron control system.

Grouping

System keypads can control any motor or group of motors without a separate group controller or additional interface.

System groups and subgroups can be reconfigured at the point of control without rewiring and without access to the QMT.

Notes:

This product may be purchased from an authorized Crestron dealer. To find a dealer, please contact the Crestron sales representative for your area. A list of sales representatives is available online at www.crestron.com/salesreps or by calling 800-237-2041.

Specifications subject to change without notice. Crestron is not responsible for errors in typography or photography.

Crestron, the Crestron logo and QMT are trademarks or registered trademarks of Crestron Electronics, Inc. in the United States, other countries or both. Other trademarks and trade names may be used in this document to refer to either the entities claiming the marks and names or their products. Crestron disclaims proprietary interest in the marks and names of others. ©2012 Crestron Electronics, Inc.

MOUNTING OPTIONS

Depending on window dimensions, brackets can be mounted inside the window frame, outside the window frame, or in a pocket.

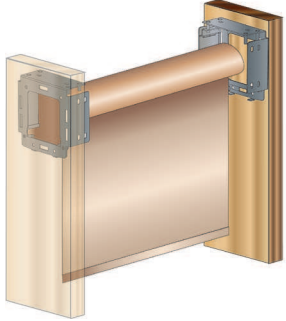

Inside Mount

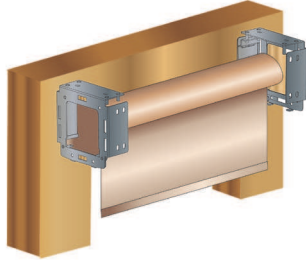

Outside Mount

DRIVE SIDE OPTIONS

QMT can be mounted on the left or right of the shade.

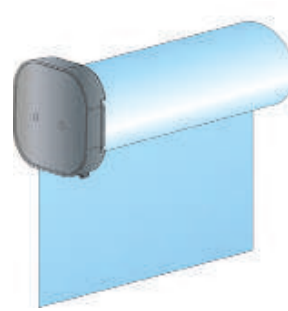

Left Drive Side



Right Drive Side

FABRIC DROP OPTIONS



Regular Roll



Reverse Roll

HEM BAR OPTIONS

There are four options for the Hem bar:



Open Pocket



Sealed Pocket



Architectural Wrapped



Architectural Exposed

Architectural Exposed bar option available in the following finishes:

White, Ivory, Clear Anodized, Black, Bronze or Custom.

FABRIC OPTIONS

- **Transparent:** Transmits light so that objects or images are seen through the weave.
- **Translucent:** Transmits diffused light, eliminating the perception of distinct images
- **Blackout:** Provides advanced light blockage and privacy.

BRACKET OPTIONS

Crestron Shading Solutions Architectural Series brackets employ a one-piece design to maximize ease and flexibility of installation.

1) Single Bracket

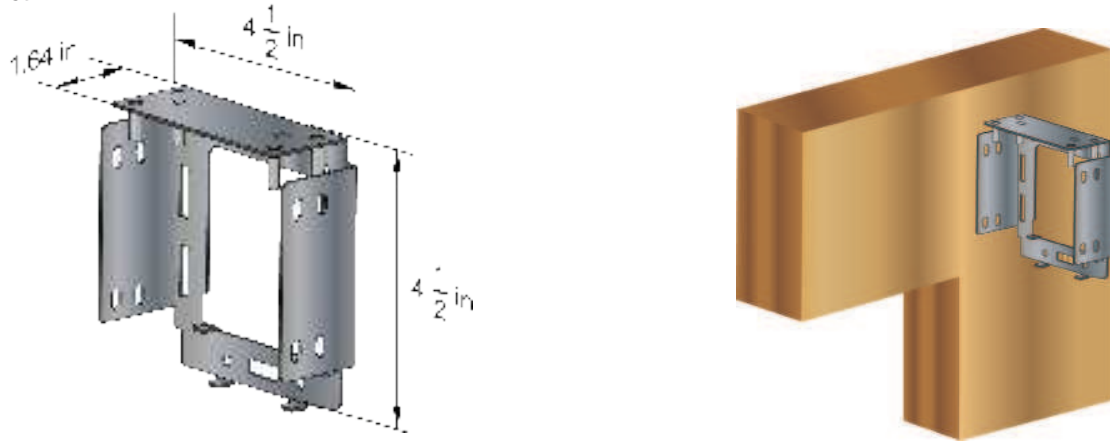

2) Dual Mount Bracket

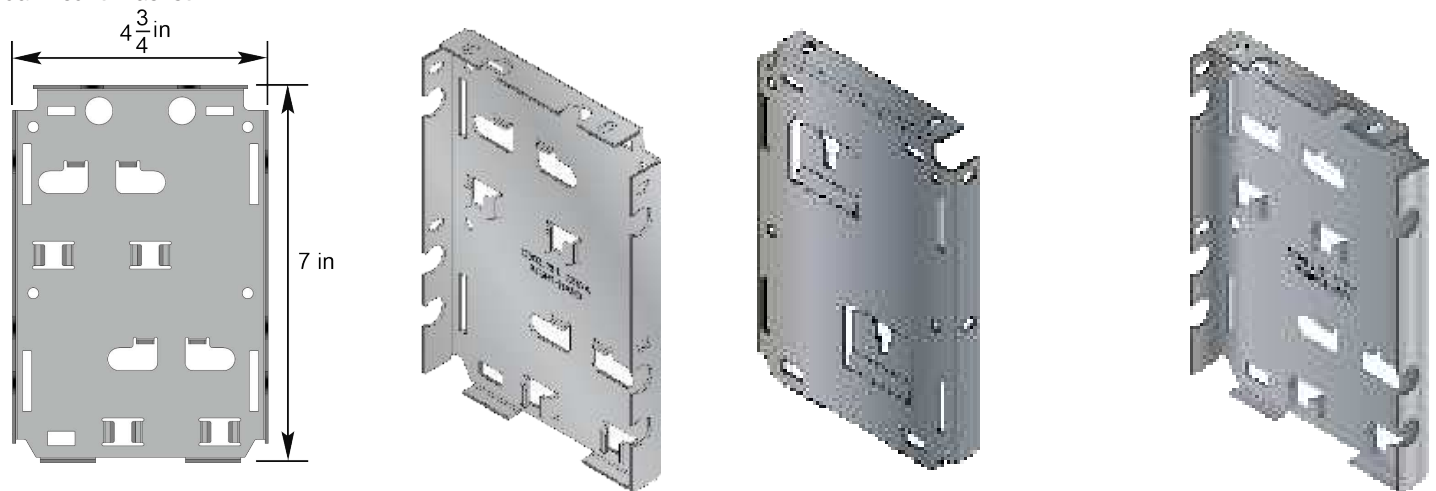

3) XL Bracket

