

C2N-MNETRPT

infiNET™ Wireless Expander

- > infiNET™ mesh network technology
- > Extends wireless range up to 150 feet (46 m) indoors
- > Automatic discovery for fast, easy setup
- > Wi-Fi friendly channel assignment

The C2N-MNETRPT is a 2-way RF wireless expander designed to extend the coverage of an infiNET™ wireless network. Requiring only an AC power source, the C2N-MNETRPT can be installed where needed to fill a “dead” space between two or more infiNET devices.

Crestron® infiNET wireless technology provides reliable 2-way communications throughout a residential or commercial structure without the need for physical control wiring. Employing a 2.4 GHz mesh network topology, each infiNET device on the network (including the C2N-MNETRPT) functions as an expander, passing command signals through to every other device within range (approximately 150 feet or 46 meters indoors), ensuring that every command reaches its intended destination without disruption. Each infiNET device that is added to the network effectively increases the range and stability of the entire network by providing multiple redundant signal paths.^[1]

Setting up a complete infiNET network is simple, utilizing dynamic discovery to locate and acquire each device and expander automatically.

SPECIFICATIONS

Wireless

RF Transceiver: infiNET™ 2-way RF, 2.4 GHz ISM Channels 11-26 (2400 to 2483.5 MHz), IEEE 802.15.4 compliant

Range (typical): 150 feet (46 m) indoor, 250 feet (76 m) outdoor to nearest mesh network device(s), subject to site-specific conditions

Gateway: Requires a C2N-MNETGW infiNET gateway

Controls & Indicators

PWR: (1) green LED, indicates operating power supplied from power pack

MNET: (1) yellow LED, indicates communication with the infiNET network

SETUP: (1) Recessed pushbutton with red LED, used to link the repeater to a gateway

Connectors

COM: (1) 6-pin RJ11 female;
RS-232 PC console port

PWR: (1) 2.5 x 5.5 mm DC power connector;
12 Volt DC power input, power pack included



Power Requirements

Power Pack (US/North America): 0.5 Amps @ 12 Volts DC;
120 Volts AC, 60 Hz power pack, model PW-1205 included

Power Pack (International): 1.5 Amps @ 12 Volts DC;
230 Volts AC, 50 Hz power pack, model PWI-1215 included

Enclosure

Metal with black finish, freestanding or surface mount

Environmental

Temperature: 32° to 104°F (0° to 40°C)

Humidity: 10% to 90% RH (non-condensing)

Dimensions

(Without antenna)

Height: 1.24 in (32 mm)

Width: 2.47 in (63 mm)

Depth: 3.88 in (99 mm)

Weight

8.3 oz (240 g)

C2N-MNETRPT infiNET™ Wireless Expander

MODELS & ACCESSORIES

Available Models

C2N-MNETRPT: infiNET™ Wireless Expander

C2NI-MNETRPT: infiNET™ Wireless Expander - International Version, 230V

Included Accessories

PW-1205: Power Pack, Wall, 12VDC, 0.5A, 120VAC (Qty. 1 included with C2N-MNETRPT)

PWI-1215: Power Pack, Desktop, 12VDC, 1.5A, 230VAC (Qty. 1 included with C2NI-MNETRPT)

Notes:

1. Battery-powered infiNET devices do not provide expander functionality, and may have reduced RF range capabilities. Consult the specifications for each network device to confirm its actual wireless capabilities.

This product may be purchased from an authorized Crestron dealer. To find a dealer, please contact the Crestron sales representative for your area. A list of sales representatives is available online at www.crestron.com/salesreps or by calling 800-237-2041.

The specific patents that cover Crestron products are listed online at: patents.crestron.com.

Crestron, the Crestron logo, and infiNET are either trademarks or registered trademarks of Crestron Electronics, Inc. in the United States and/or other countries. Other trademarks, registered trademarks, and trade names may be used in this document to refer to either the entities claiming the marks and names or their products. Crestron disclaims any proprietary interest in the marks and names of others. Crestron is not responsible for errors in typography or photography. Specifications are subject to change without notice.

©2013 Crestron Electronics, Inc.

Front

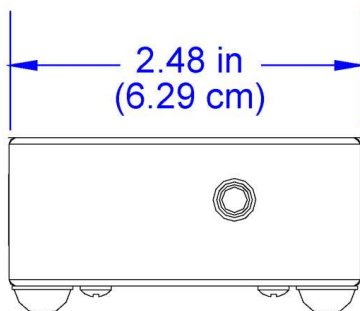

Back

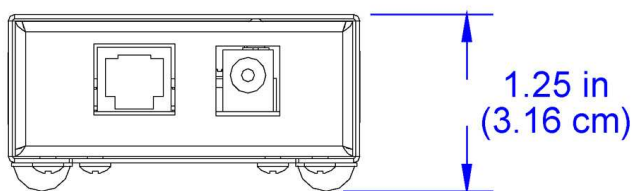

Top

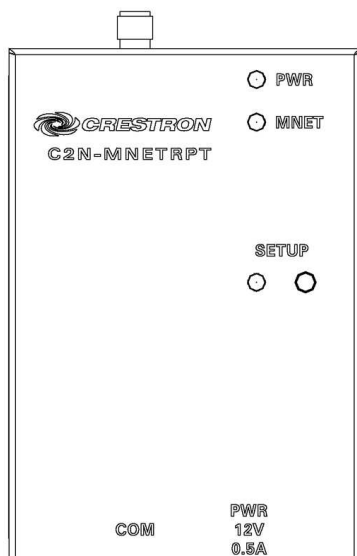

Side

