

C2N-FTB-D

FlipTop™ Control Center

- > Stylish flush-mount FlipTop™ housing
- > Integrated keypad with dual bargraphs
- > Easy pull-out universal cable management
- > Optional cable retractors
- > Dual AC power outlets
- > Cresnet® communications
- > Black anodized or brushed aluminum finish

The C2N-FTB-D FlipTop™ Control Center by Crestron® provides an ingenious control and connectivity solution in a stylish flush mount tabletop design. Popping open the “FlipTop” lid exposes a pushbutton keypad, perfectly angled for easy access and intuitive operation. The built-in cable storage compartment keeps interface cables at the ready for plugging in laptop computers, mobile devices, AV sources, and other equipment.

FlipTop Control Centers are ideal for use with AV distribution systems like Crestron [DigitalMedia™](#), allowing the signal transmitters and receivers to be installed out of sight beneath the tabletop, with the user interface cables organized neatly within the cable storage compartment. The integrated keypad can be used to select sources, adjust the volume, and control display devices among other functions.

FlipTop Housing

Handsomely finished in a choice of black anodized or brushed aluminum, the C2N-FTB-D lends a contemporary metallic accent to conference tables and podiums. It mounts flush in virtually any flat, horizontal surface up to 1-13/16 inch (46 mm) thick for a clean, low-profile appearance.

Integrated Keypad

The customizable keypad provides 10 to 20 programmable pushbuttons for control of AV, lighting, and other functions. All button caps are custom engravable^[1] and include LED feedback indicators. Two LED bargraphs are also provided to display level settings and other parameters. To prevent accidental button presses, the keypad is automatically disabled whenever the lid is not fully opened.

Cable Storage Compartment

The C2N-FTB-D provides easy pull-out storage for [Crestron Certified Interface Cables](#)^[2] and a wide variety of other AV, data, and communication cables. Eight grommets are provided in the bottom of the storage compartment to accommodate either premade or custom cables, allowing each cable to be pulled out smoothly as needed. When not in use, the user end of each cable stows neatly within the storage compartment while excess cable simply drops out-of-sight below the box.

Cable Retractor Option

For an even more refined cable management solution, the C2N-FTB-D accommodates up to three Crestron [CBLR2 Series Cable Retractors](#). Crestron cable retractors feature a patented mechanism that ensures smooth operation while eliminating hanging cable loops beneath the table.^[3]



Dual AC Power Outlets

For complete connectivity, the C2N-FTB-D includes two AC power receptacles within the FlipTop compartment.

SPECIFICATIONS

Buttons & Indicators

Keypad: Programmable keypad allowing variable combinations of large and small engravable buttons, 10 minimum (all large) to 20 maximum (all small)^[1]

Button Feedback: (1) red LED per button, programmable

Bargraphs: (2) red 8-segment LED bargraphs, programmable

PWR: (1) green LED, indicates DC power supplied from the Cresnet® control network

NET: (1) yellow LED, indicates communication with the Cresnet system

SETUP (bottom): (1) miniature pushbutton and red LED, used for touch-settable ID (TSID)

Communications

Cresnet: Cresnet slave mode

Connectors - Front Panel

125V~50/60Hz 10A: (2) Grounded AC sockets;

AC power pass-thru outlets;

Maximum Load: 10 Amps (total) @ 125 Volts AC, 50/60 Hz

C2N-FTB-D FlipTop™ Control Center

Connectors – Bottom Panel

125V~50/60Hz 10A: (1) 9 ft grounded AC line cord;
Passes through to front panel AC power outlets

NET: (2) 4-pin 3.5mm detachable terminal blocks;
Cresnet slave ports, paralleled;
Connect to Cresnet control network

G: 6-32 screw, chassis ground lug

Power Requirements

Cresnet Power Usage: 2 Watts (0.083 Amp @ 24 Volts DC)

Environmental

Temperature: 41° to 104°F (5° to 40°C)

Humidity: 10% to 90% RH (non-condensing)

Heat Dissipation: 6 BTU/hr

Enclosure

Chassis: Metal, black

Cover: Aluminum, black anodized or brushed aluminum finish

Keypad: Plastic, black, engravable buttons^[1]

Mounting: Flush tabletop mount, 1-13/16 in (46 mm) maximum surface thickness, 5-5/16 in (135 mm) deep x 6-3/8 in (162 mm) wide cutout (template provided)

Dimensions

Height: 5.39 in (137 mm) with lid closed

Width: 6.75 in (172 mm)

Depth: 5.71 in (145 mm), 7.21 in (184 mm) with mounting brackets

Weight

3.75 lb (1.70 kg)

MODELS & ACCESSORIES

Available Models

C2N-FTB-D-B: FlipTop™ Control Center, Black Anodized

C2N-FTB-D-BALUM: FlipTop™ Control Center, Brushed Aluminum [Special Order]

Available Accessories

FT-BTNB-L: Single Large Engravable Button Cap for FlipTop™ Boxes with Keypads

FT-BTNB-S: Dual Small Engravable Button Caps for FlipTop™ Boxes with Keypads

CBLR2 Series: Cable Retractors

CBLRA-BRKT-3-FT: Cable Retractor Mounting Bracket for Small FlipTops™

CBLRA-INSERT-BLANK: Blank Spacer Insert for Cable Retractor Mounting Brackets

CBLRA-INSERT-2WIRE: 2-Wire Spacer Insert for Cable Retractor Mounting Brackets

CBL Series: Crestron® Certified Interface Cables

CRESNET-NP: Cresnet® Control Cable, non-plenum

CRESNET-P: Cresnet® Control Cable, plenum

CRESNET-HP-NP: Cresnet® “High-Power” Control Cable, non-plenum

Notes:

1. Ships with 10 single large button caps. Dual small button caps and all custom engraving sold separately.
2. Interface cables sold separately.
3. Adding the cable retractor option removes all eight of the standard grommets cable holes. Cable retractors and related accessories are sold separately. See the [CBLR2](#) spec sheet for more information.

This product may be purchased from an authorized Crestron dealer. To find a dealer, please contact the Crestron sales representative for your area. A list of sales representatives is available online at www.crestron.com/salesreps or by calling 800-237-2041.

The specific patents that cover Crestron products are listed online at: patents.crestron.com.

Crestron, the Crestron logo, Cresnet, DigitalMedia, FlipTop, and FlipTops are either trademarks or registered trademarks of Crestron Electronics, Inc. in the United States and/or other countries. Other trademarks, registered trademarks, and trade names may be used in this document to refer to either the entities claiming the marks and names or their products. Crestron disclaims any proprietary interest in the marks and names of others. Crestron is not responsible for errors in typography or photography. Specifications are subject to change without notice.
©2014 Crestron Electronics, Inc.

C2N-FTB-D FlipTop™ Control Center

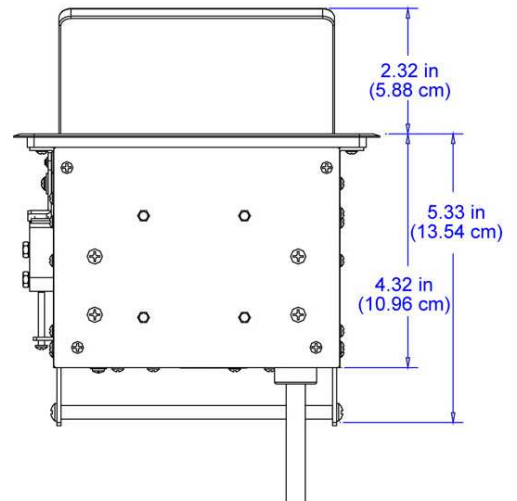
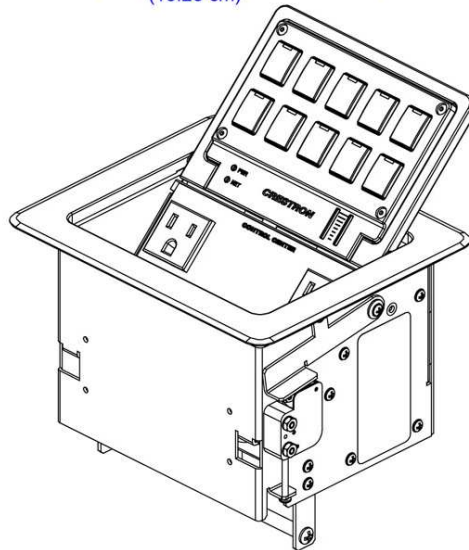
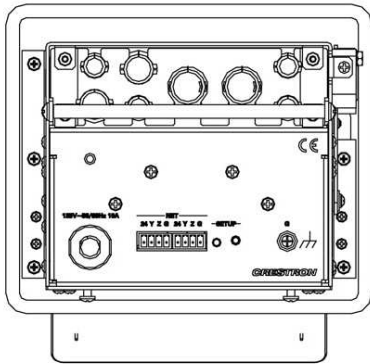
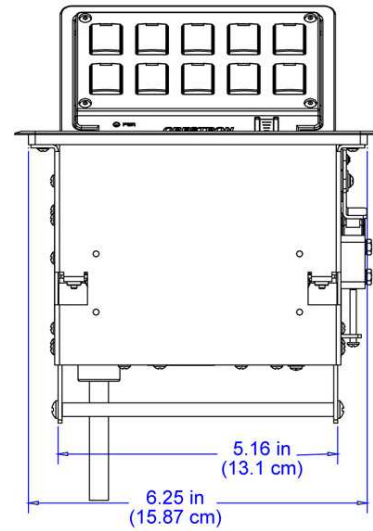
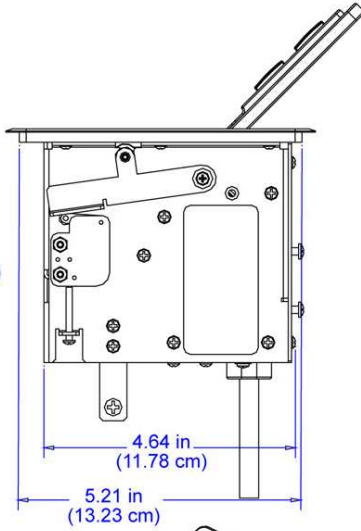
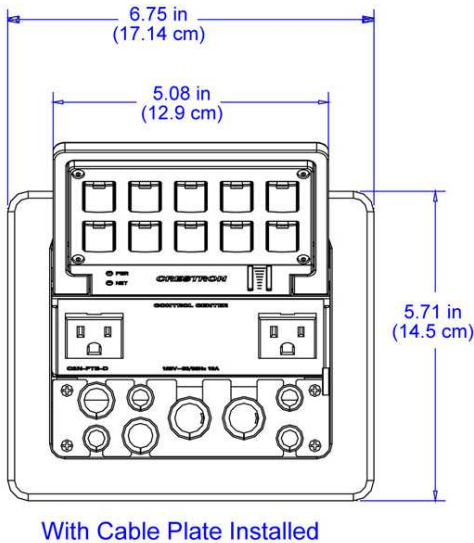

With Mounting Hardware Installed

