



**SPECIFICATION
FOR
LCD Module
RX043A-0204**

MODULE:	RX043A-0204
CUSTOMER:	

REV	DESCRIPTION	DATE
1	FIRST ISSUE	2013.03.02

TZD	INITIAL	DATE
APREPARED BY		
CHECKED BY		
APPROVED BY		

CUSTOMER	INITIAL	DATE
APPROVED BY		



Revision History

Data	Rev. No.	Page	Summary
2013.03.02	1.0		FIRST ISSUE

ROGIN ELECTRONICS



Contents

General Description

1. Optical Characteristics
2. Electrical Characteristics
3. Outline dimension
4. Input Terminal Pin Assignment
5. Timing Characteristic
6. Reliability Test Result
7. Packing
8. Cautions and Handling Precautions

ROGIN ELECTRONICS



General Description

* Description

This is a color active matrix TFT (Thin Film Transistor) LCD (liquid crystal display) that uses amorphous silicon TFT as a switching device. This model is composed of a Transmissive type TFT-LCD Panel, driver circuit, back-light unit. The resolution of a 4.3" TFT-LCD contains 480RGB x 272 pixels, and can display up to 16.7M colors.

* Features

- Low Input Voltage: VCC: 2.5V~3.3V
- Display Colors of TFT LCD: 262K colors
- CPU Interface: 24bit parallel (RGB) input timing
- Internal Power Supply Circuit.

General Information Items	Specification	Unit	Note
	Main Panel		
Display area(AA)	95.04(H) * 53.856(V) (4.3 inch)	mm	-
Driver element	a-Si TFT active matrix	-	-
Display colors	262k	colors	-
Color Gamut	50	%	-
Number of pixels	480(RGB) *272	dots	-
Pixel arrangement	RGB vertical stripe	-	-
Pixel pitch	0.198(H) *0.198(V)	mm	-
Viewing angle	6:00	o'clock	-
Drive IC	ILI6480	-	-
Display mode	Transmissive/ Normally White	-	-
Operating temperature	-20~+70	°C	-
Storage temperature	-30~+80	°C	-

* Mechanical Information

Item		Min.	Typ.	Max.	Unit	Note
Module size	Horizontal(H)	-	105.5	-	mm	-
	Vertical(V)	-	67.2	-	mm	-
	Depth(D)		2.95		mm	-
Weight		-	TBD	-	g	-



1. Optical Characteristics

The following items are measured under stable conditions. The optical characteristics should be measured in a dark room or equivalent state

ITEM	SYMBOL	CONDITION	MIN.	TYP.	MAX.	UNIT	REMARK
Transmittance	T		5.6	5.9		%	Note 2
Contrast Ratio	CR	*1)	250	350	--	--	Note 3
Response Time	Tr+ Tf	*3)	-	30	45	ms	Note 4
Viewing Angle	Vertical	θ *2)	CR \geq 10	90	110	--	Note 5
	Horizontal	ϕ *2)				110	
Color Filter Chromacicity with C light	White	x y	$\theta = \phi = 0^\circ$	0.282	0.302	0.322	Note 6
				0.318	0.338	0.358	
	Red	x y	$\theta = \phi = 0^\circ$	0.586	0.606	0.626	
				0.305	0.325	0.345	
	Green	x y	$\theta = \phi = 0^\circ$	0.283	0.303	0.323	
				0.547	0.567	0.587	
Blue	x y	$\theta = \phi = 0^\circ$	0.127	0.147	0.167		
			0.121	0.161	0.181		
NTSC			-	50%	-		

Note 1.Ambient condition : $25^\circ\text{C} \pm 2^\circ\text{C}$, $60 \pm 10\% \text{RH}$, under 10 Lux in the darkroom .

Note 2.Measure device : BM-5A (TOPCON) , viewing cone= 2° , $I_L=20\text{mA}$.

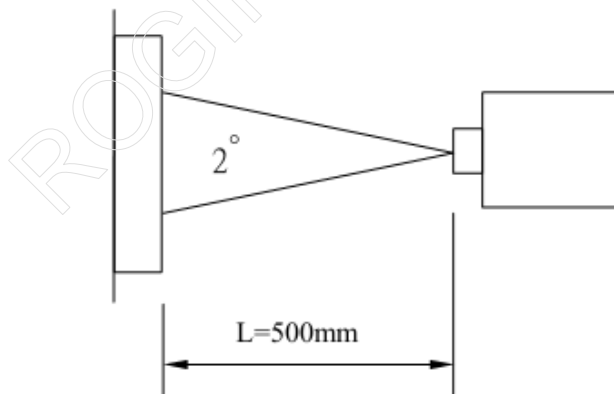

Note 3. Definition of Contrast Ratio :

$$\text{CR} = \text{White Luminance (ON)} / \text{Black Luminance (OFF)}$$



Note 4. Definition of response time : The response time is defined as the time interval between the 10% and 90% amplitudes.

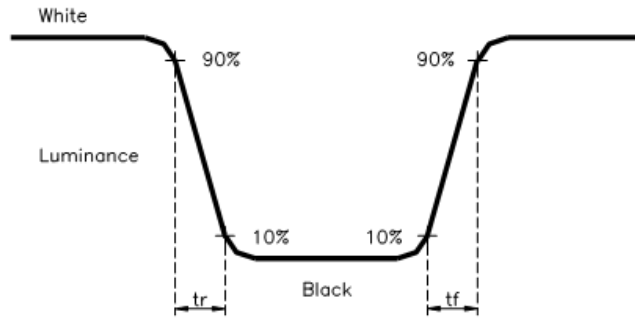

Note 5. Definition of view angle(θ , ψ) :

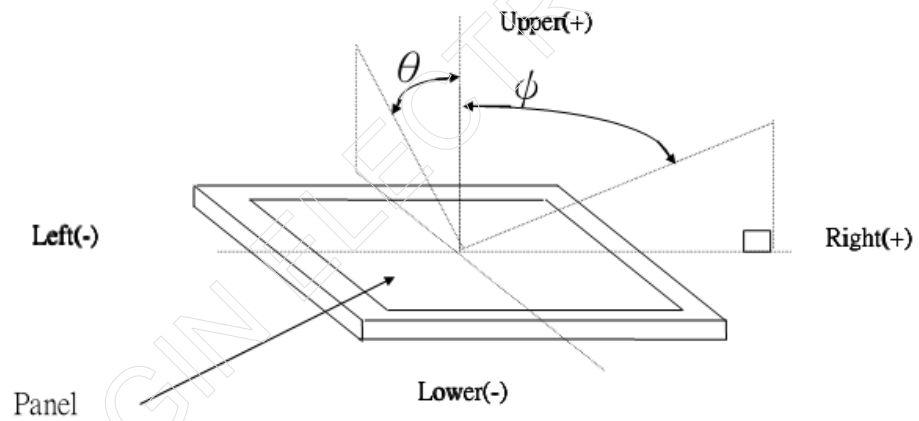

Note 6. Light source: C light.



2. Electrical Characteristics

2.1 Absolute Maximum Rating (Ta=25 VSS=0V)

Item	Symbol	Min.	Max.	Unit	Note
Power Supply Voltage	V _{CC}	-0.3	3.2	V	1, 2
Logic Signal Input /Output Voltage	V _{I/OVCC}	-0.3	V _{CC} +0.5	V	
Power Supply Voltage for LCD	V _{OP}	0	3.2	V	
Current of LED	I _{LED}	0	120	mA	

Notes:

1. If the module is above these absolute maximum ratings. It may become permanently damaged.

Using the module within the following electrical characteristic conditions are also exceeded, the module will malfunction and cause poor reliability.

2. V_{CC} > V_{SS} must be maintained.

3. Please be sure users are grounded when handling LCD Module.

2.2 DC Electrical Characteristics

Parameter	Symbol	Condition	Min	Typ	Max	Unit	Note	
Power supply	V _{CC}	Ta=25°C	2.6	3.3	3.6	V		
Input voltage	'H'	V _{IH}	V _{CC} =2.8V	0.8V _{CC}	-	V _{CC}	V	
	'L'	V _{IL}	V _{CC} =2.8V	0	-	0.2V _{CC}	V	
Current Consumption	I _{CC1}	Normal mode	-	-	110	mA	2	
	I _{CC2}	Sleep mode	-	0.03	0.09	mA	2	
Clock Frequency	f _{CLK}	-	-	-	-	MHz		

Note:

1:When an optimum contrast is obtained in transmissive mode.

2: Tested in 1×1 chessboard pattern.



2.3 LED Backlight Characteristics

The back-light system is edge-lighting type with 4chips White LED in serial

Item	Symbol	Min.	Typ.	Max.	Unit	Note
Forward Current	I_F	-	15	-	mA	
Forward Voltage	V_F		21.2		V	-
LCM Luminance	L_V		TBD	-	cd/m ²	
Uniformity	AVg	80	-	-	%	-

ROGIN ELECTRONICS



3.Outline dimension

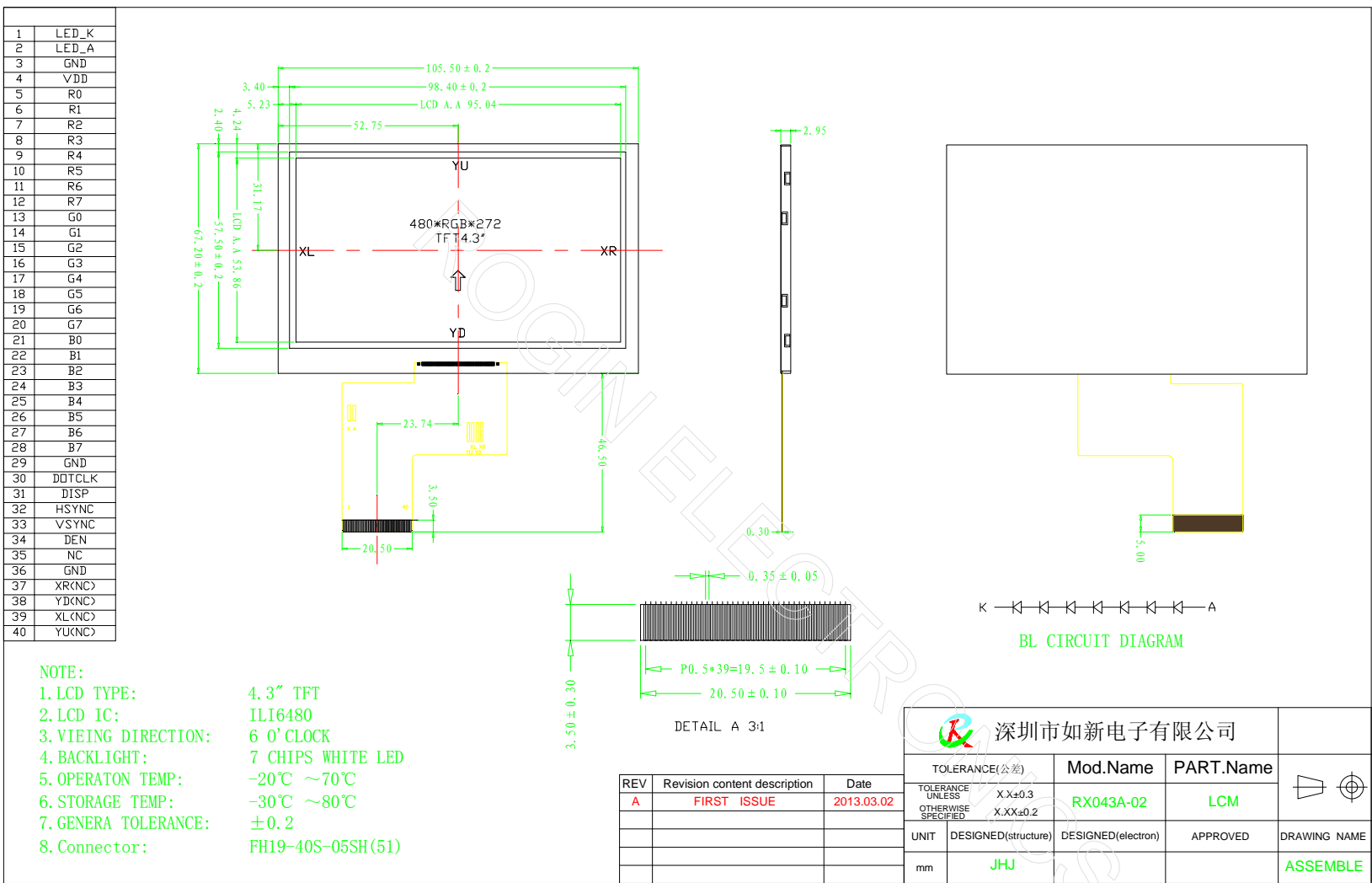

REV	Revision content description	Date
A	FIRST ISSUE	2013.03.02

深圳市如新电子有限公司			
TOLERANCE(公差) TOLERANCE UNLESS OTHERWISE SPECIFIED	Mod.Name	PART.Name	
X.X±0.3 X.XX±0.2	RX043A-02	LCM	
UNIT	DESIGNED(structure)	DESIGNED(electron)	APPROVED
mm	JHJ		DRAWING NAME ASSEMBLE



4. Input terminal Pin Assignment

Pin NO.	Symbol	Function
1	LED_K	Backlight-
2	LED_A	Backlight+
3	GND	Ground
4	VDD	Power for Digital Circuit
5	R0	Red Date Bit0
6	R1	Red Date Bit1
7	R2	Red Date Bit2
8	R3	Red Date Bit3
9	R4	Red Date Bit4
10	R5	Red Date Bit5
11	R6	Red Date Bit6
12	R7	Red Date Bit7
13	G0	Green Date Bit0
14	G1	Green Date Bit1
15	G2	Green Date Bit2
16	G3	Green Date Bit3
17	G4	Green Date Bit4
18	G5	Green Date Bit5
19	G6	Green Date Bit6
20	G7	Green Date Bit7
21	B0	Blue Date Bit0
22	B1	Blue Date Bit1
23	B2	Blue Date Bit2
24	B3	Blue Date Bit3
25	B4	Blue Date Bit4
26	B5	Blue Date Bit5
27	B6	Blue Date Bit6
28	B7	Blue Date Bit7
29	GND	Ground
30	DOTCLK	Dot Date Clock
31	DISP	Display ON/OFF
32	HSYNC	Horizontal SYNC input
33	VSYNC	Vertical SYNC input
34	DEN	Data enable input
35	NC	NC
36	GND	Ground
37	XR(NC)	TP XR(NC)
38	YD(NC)	TP YD(NC)
39	XL(NC)	TP XL(NC)
40	YU(NC)	TP YU(NC)



5. Timing Characteristic

Please refer to OTA5180A data sheet for more details.

Parameter	Symbol	Value			Unit
		Min.	Typ.	Max.	
Horizontal display area	thdisp	480			DCLK
DCLK frequency	Fclk	5	9	12	MHZ
1 Horizontal line	th	490	531	605	DCLK
HSYNC pulse width	thw	1	2	-	
HSYNC Back Porch (blanking)	thbp	8	43	-	
HSYNC front porch	thfp	2	8	-	
Vertical display area	tvdisp	272			H
VSD period time	tv	275	288	335	
VSD pulse width	tvw	1	10	-	
VSD Back Porch (blanking)	tvbp	2	12	-	
VSD front porch	tvfp	1	4	-	

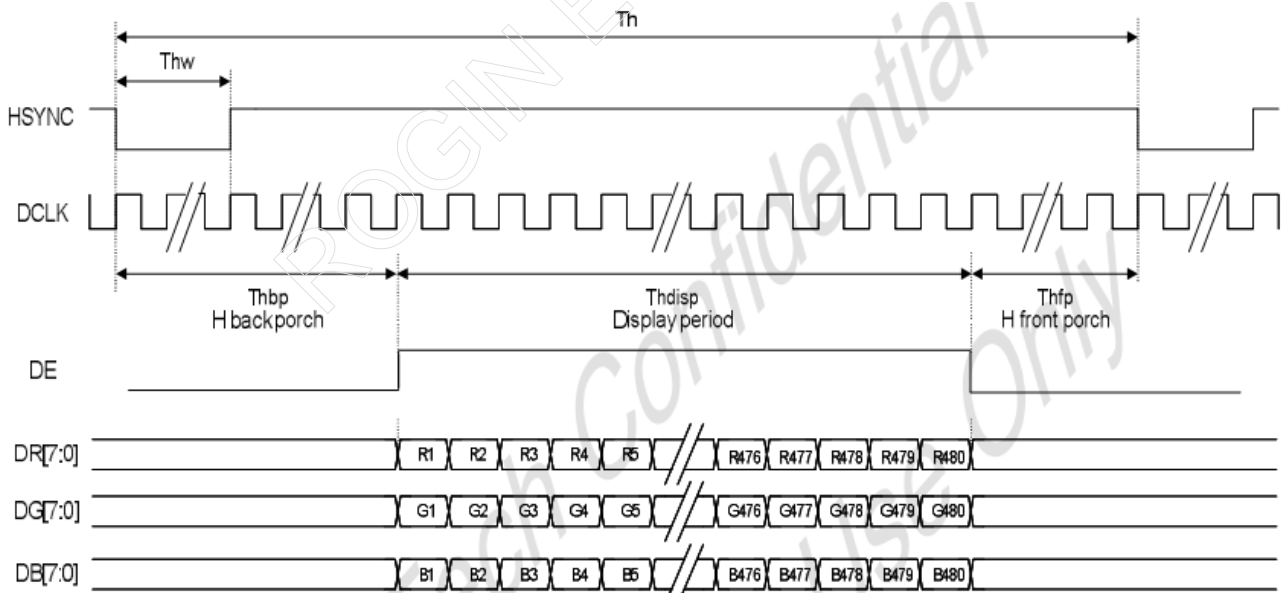



6. Reliability Test Result

Item	Condition	Sample Size	Test Result	Note
Low Temperature Operating Life test	-20°C, 96HR	3ea	pass	-
Thermal Humidity Operating Life test	40°C, 90%RH, 96HR	3ea	pass	-
Temperature Cycle ON/OFF test	-20°C ↔ 70°C, ON/OFF, 20CYC	3ea	pass	(1)
High Temperature Storage test	80°C, 96HR	3ea	pass	-
Low Temperature Storage test	-30°C, 96HR	3ea	pass	-
Thermal Shock Resistance	The sample should be allowed to stand the following 5 cycles of operation: TSTL for 30 minutes -> normal temperature for 5 minutes -> TSTH for 30 minutes -> normal temperature for 5 minutes, as one cycle, then taking it out and drying it at normal temperature, and allowing it stand for 24 hours	3ea	pass	
Box Drop Test	1 Corner 3 Edges 6 faces, 66cm(MEDIUM BOX)	1box	pass	-

Note (1) ON Time over 10 seconds, OFF Time under 10 seconds

7. Packing

TBD



8. Cautions and Handling Precautions

8.1 Handling and Operating the Module

(1) When the module is assembled, it should be attached to the system firmly.

Do not warp or twist the module during assembly work.

(2) Protect the module from physical shock or any force. In addition to damage, this may cause improper operation or damage to the module and back-light unit.

(3) Note that polarizer is very fragile and could be easily damaged. Do not press or scratch the surface.

(4) Do not allow drops of water or chemicals to remain on the display surface.

If you have the droplets for a long time, staining and discoloration may occur.

(5) If the surface of the polarizer is dirty, clean it using some absorbent cotton or soft cloth.

(6) The desirable cleaners are water, IPA (Isopropyl Alcohol) or Hexane.

Do not use ketene type materials (ex. Acetone), Ethyl alcohol, Toluene, Ethyl acid or Methyl chloride. It might permanent damage to the polarizer due to chemical reaction.

(7) If the liquid crystal material leaks from the panel, it should be kept away from the eyes or mouth.

In case of contact with hands, legs, or clothes, it must be washed away thoroughly with soap.

(8) Protect the module from static; it may cause damage to the CMOS ICs.

(9) Use finger-stalls with soft gloves in order to keep display clean during the incoming inspection and assembly process.

(10) Do not disassemble the module.

(11) Protection film for polarizer on the module shall be slowly peeled off just before use so that the electrostatic charge can be minimized.

(12) Pins of I/F connector shall not be touched directly with bare hands.

(13) Do not connect, disconnect the module in the "Power ON" condition.

(14) Power supply should always be turned on/off by the item 6.1 Power On Sequence & 6.2 Power Off Sequence

8.2 Storage and Transportation.

(1) Do not leave the panel in high temperature, and high humidity for a long time.

It is highly recommended to store the module with temperature from 0 to 35 °C and relative humidity of less than 70%

(2) Do not store the TFT-LCD module in direct sunlight.

(3) The module shall be stored in a dark place. When storing the modules for a long time, be sure to adopt effective measures for protecting the modules from strong ultraviolet radiation, sunlight, or fluorescent light.

(4) It is recommended that the modules should be stored under a condition where no condensation is allowed. Formation of dewdrops may cause an abnormal operation or a failure of the module.



In particular, the greatest possible care should be taken to prevent any module from being operated where condensation has occurred inside.

(5) This panel has its circuitry FPC on the bottom side and should be handled carefully in order not to be stressed.

ROGIN ELECTRONICS