

144L...-PCB Series

Signal conditioned precision pressure transducers

FEATURES

- 0...5 to 0...50 mbar, 0...1 to 0...20 "H₂O gage or differential pressure (custom calibrations available)
- 0...5 V output
- Single power supply
- Internal supply regulation
- Precision temperature compensated and calibrated



SERVICE

Non-corrosive, non-ionic working fluids, such as dry air and dry gases

SPECIFICATIONS

Maximum ratings

Supply voltage	7.5...24 V
Maximum load current	
source	20 mA
sink	10 mA
Temperature limits	
Storage	-25 to 85°C
Operating	-10 to 70°C
Compensated	0 to 50°C
Lead temperature (10 sec soldering)	300°C
Humidity limits	
pressure inlets only	0 - 95 %RH
Proof pressure ¹	
144LP...-PCB	300 mbar
144LU...-PCB	4 psi
Common mode pressure	
144LP...-PCB	600 mbar
144LU...-PCB	8 psi

ELECTRICAL CONNECTION

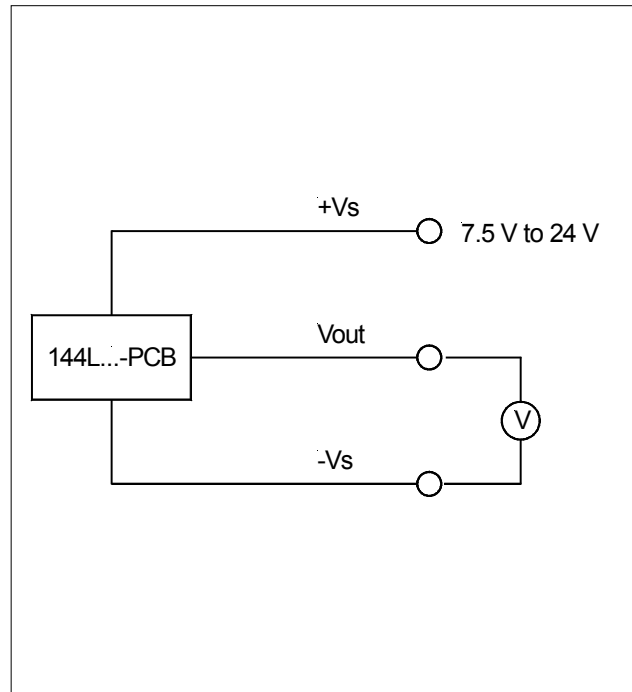

144L...-PCB Series

Signal conditioned precision pressure transducers

PERFORMANCE CHARACTERISTICS

(unless otherwise noted $V_s = 8\text{ V}$, $R_L > 100\text{ k}\Omega$, $t_{\text{amb}} = 25^\circ\text{C}$)

Characteristics		Min.	Typ.	Max.	Unit
Operating pressure ²	144LP05D-PCB	0		5	mbar
	144LP10D-PCB	0		10	
	144LP20D-PCB	0		20	
	144LP50D-PCB	0		50	
	144LU01D-PCB	0		1	"H ₂ O
	144LU02D-PCB	0		2	
	144LU05D-PCB	0		5	
	144LU10D-PCB	0		10	
144LU20D-PCB	0		20		
Zero pressure offset		-0.05	0	0.05	V
Full scale output		4.9	5.0	5.1	
Full scale span ³			5.0		
Thermal effects (0 to 50°C) ⁴	Offset	144LU01D-PCB	±0.05	±0.15	%FSO/°C
		144LU02D-PCB	±0.02	±0.07	
		144LP05D-PCB	±0.02	±0.07	
		all other devices	±0.01	±0.03	
	Span	144LU01D-PCB	±0.05	±0.10	%FSO
		all other devices	±0.02	±0.04	
Non-linearity and hysteresis (BSL) ⁵			0.1	0.5	%FSO
Long term stability ⁶			±0.2		
Response time (10 to 90%)			200		µs
Position sensitivity	144LU01D-PCB		0.5		%FSO/g
	all other devices		0.1		
Current consumption			4.2		mA
Power supply rejection	Offset		0.05		%FSOV
	Span		0.03		

Specification notes:

1. Proof pressure is the maximum pressure which may be applied without causing damage to the sensing element.
2. The output signal is proportional to the pressure applied to port B, relative to port A, e.g. the output signal increases when vacuum is applied to port A relative to port B.
3. Full scale span is the algebraic difference between the positive full scale output and the zero pressure offset.
4. Non-linearity refers to the **Best Straight Line** fit measured for offset pressure, full scale pressure and 1/2 full scale pressure.
5. Thermal effects tested and guaranteed from 0 to 50°C relative to 25°C. All specifications shown are relative to 25°C.
6. Change in output after one year or 1 million pressure cycles.

144L...-PCB Series

Signal conditioned precision pressure transducers

OUTLINE DRAWING

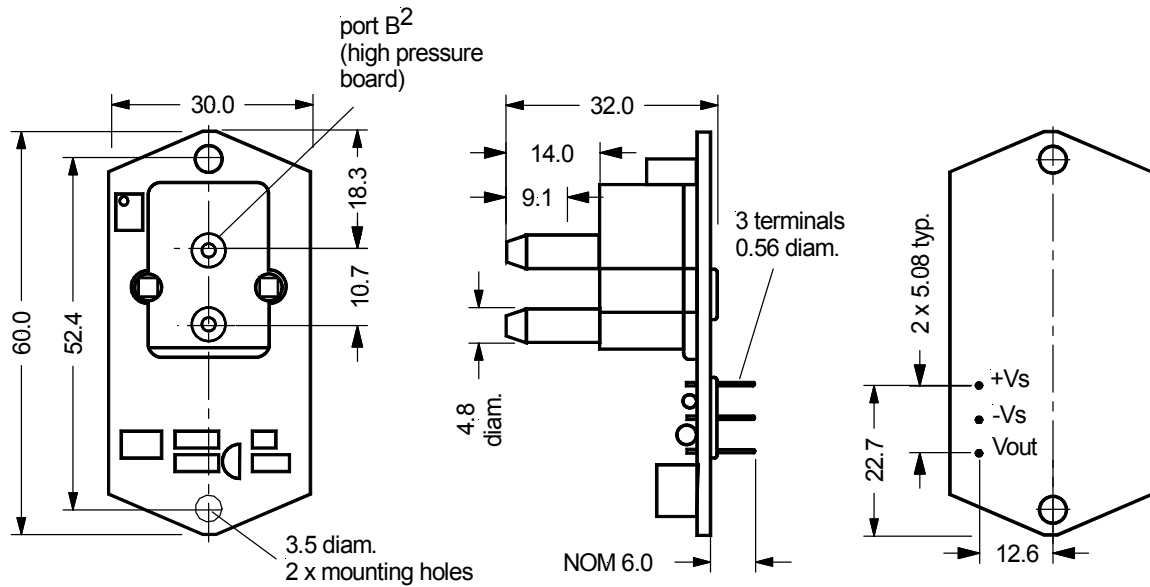

mass: 20 g

dimensions mm

144L...-PCB Series

Signal conditioned precision pressure transducers

ORDERING INFORMATION

Operating pressure	Order number
0...5 mbar	144LP05D-PCB
0...10 mbar	144LP10D-PCB
0...20 mbar	144LP20D-PCB
0...50 mbar	144LP50D-PCB
0...1 "H ₂ O	144LU01D-PCB
0...2 "H ₂ O	144LU02D-PCB
0...5 "H ₂ O	144LU05D-PCB
0...10 "H ₂ O	144LU10D-PCB
0...20 "H ₂ O	144LU20D-PCB

Custom calibrations available

First Sensor reserves the right to make changes to any products herein. First Sensor does not assume any liability arising out of the application or use of any product or circuit described herein, neither does it convey any license under its patent rights nor the rights of others.