



**USTF7025 Series**

**Size:** 2.756 in sq. x 1.0 in. thk  
(70mm sq. x 25mm thk.)

**Airflow:** 17 - 27 CFM

**Acoustical Noise:** 24.5 - 36 dB (A)

- MATERIAL:** Frame - Black PBT (UL 94V-0)  
Bearings - Ball  
Impeller - Black PBT (UL 94V-0)
- WEIGHT:** 2.72 oz. (77g)
- TERMINATION:** Lead Wires (UL 1007, AWG24)
- OPERATION TEMPERATURE:** -10° to +70° C
- INSULATION RESISTANCE:** 10 megohms min @ 500 VDC
- DIELECTRIC STRENGTH:** 500 VAC for 1 min.
- INSULATION:** Class A
- SAFETY:** Impedance & Polarity Protected
- SAFETY APPROVALS:** UL, CSA & CE
- OPERATING VOLTAGE:** 12 VDC (7 to 13.8)  
24 VDC (14 to 27.6)

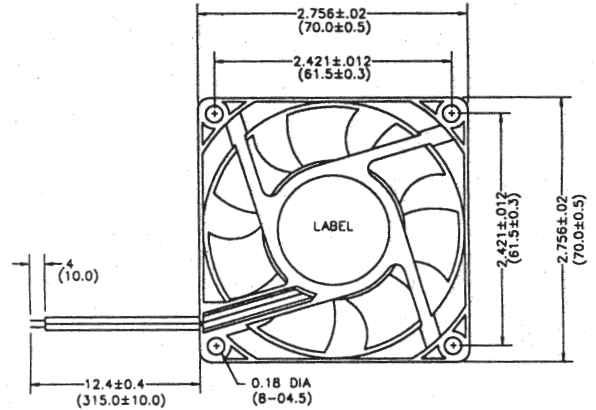
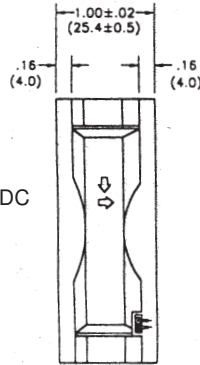

**PERFORMANCE CURVES:** (Obtained with test chamber and methods in accordance with AMCA Std. 210-74)

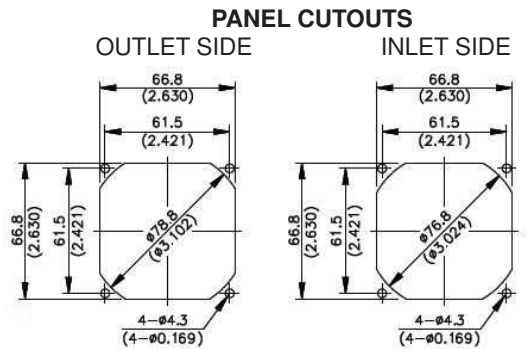
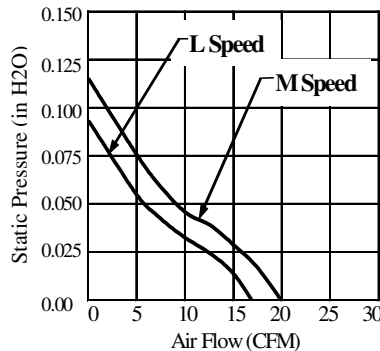
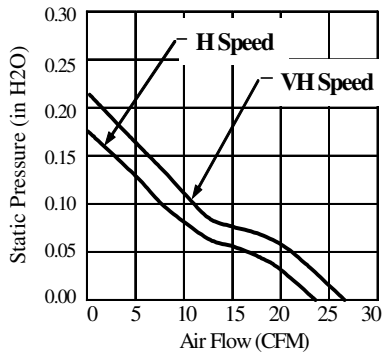

**SPECIFICATIONS:** (All values are typical)

PART NUMBER	VOLTS	WATTS	AMPS	RPM	NOISE dB (A) @ 1M	CFM
USTF702512VHW	12VDC	2.04	0.17	4000	36.0	27.0
USTF702512HW	12VDC	1.56	0.13	3600	32.5	24.0
USTF702512MW	12VDC	1.20	0.10	3000	27.0	20.0
USTF702512LW	12VDC	0.96	0.08	2600	24.5	17.0
USTF702524VHW	24VDC	2.40	0.10	4000	36.0	27.0
USTF702524HW	24VDC	1.92	0.08	3600	32.5	24.0
USTF702524MW	24VDC	1.44	0.06	3000	27.0	20.0
USTF702524LW	24VDC	1.20	0.05	2600	24.5	17.0

MODELS AVAILABLE ON REQUEST:

Failure Detector - rotation sensing - Add Suffix "SR" to part number  
Speed Controller - tach output - Add Suffix "SF" to part number