



FM3045T0

FM3045T7

WARNING: Install only on surfaces or furniture of known and verified construction. The mounting structure must be stable and capable of supporting both Monitor and Mount. **DO NOT USE** in such a manner or location that may cause it to tip over. Secure furniture to the wall or floor if necessary. **DO NOT USE** on Mobile Carts/Equipment Tables or moveable furniture.

PREPARATION

Verify sufficient clearance from walls and furniture for installation and swivel action.

FURNITURE ATTACHMENT - TAPPING SCREWS

(See optional method with machine screws and barrel nuts below.)

1. Swivel the platform to expose the pre-drilled holes in the mounting plate. Mark the hole locations onto mounting surface.
2. Use a 1/8" drill bit to drill the pilot holes.
3. Align the plate and drilled holes.
4. Fasten with the (8) #14 x 1" tapping screws.

FURNITURE ATTACHMENT - MACHINE SCREWS & BARREL NUTS

1. Swivel the platform to expose the pre-drilled holes in the mounting plate. Mark the hole locations onto the mounting surface.
2. Use a 5/16" drill bit to drill through the furniture top.
3. Align the plate and drilled holes.
4. Fasten with the (8) 1/4-20 machine screws (2 lengths provided) and barrel nuts as shown.

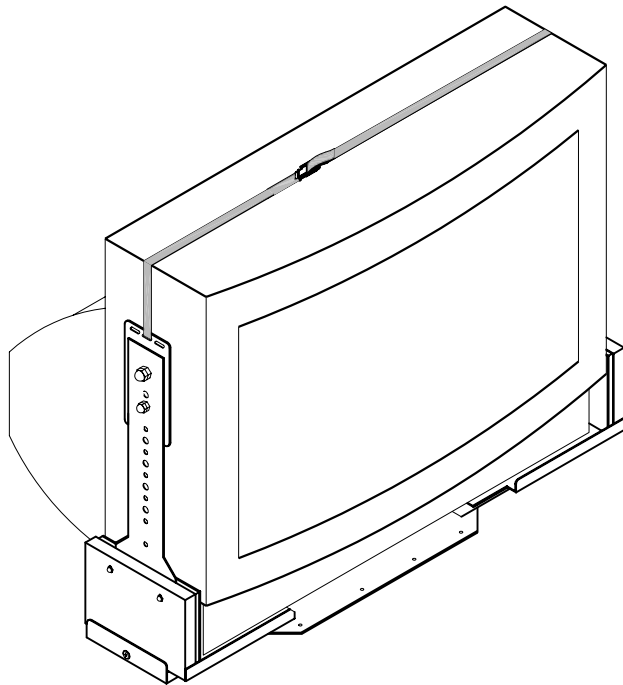

WARNING: DO NOT ATTEMPT INSTALLATION OF THIS MOUNT IF INCOMPLETE OR RECEIVED DAMAGED.

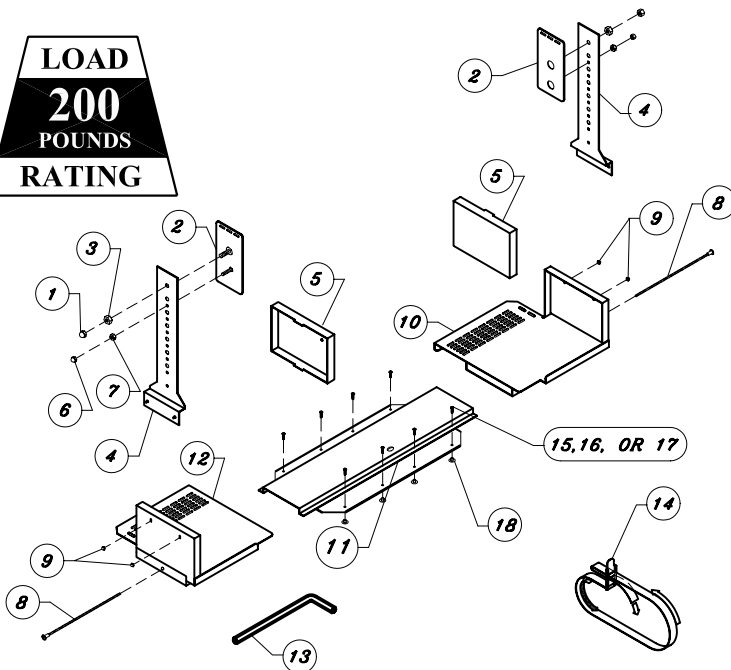

Obtain any necessary accessories or replacement items through your distributor.

PARTS LIST

DRAWING NUMBER	DESCRIPTION	QTY.
1	#1/2"-13 Acorn Nuts	2
2	Adhesive Pad Plate	2
3	#1/2"-13 Hex Nuts	2
4	Lower Side Arm	2
5	Pressure Plate	2
6	#3/8-16 Acorn Nuts	2
7	#3/8-16 Hex Nuts	2
8	Compression Screws	2
9	#1/4-20 Acorn Nuts	4
10	Platform (Right)	1
11	Platform with 0° swivel (FM3045ST0) Platform with 7° swivel (FM3045ST7)	1
12	Platform(Left)	1
13	Allen Wrench	1
14	20' Safety Strap	1
15	#14 X 1" Tapping Screws	12
16	#10-24 x 1" pan hd screws	12
17	#10-24 x 1-1/2" pan hd screws	12
18	#10-24 barrel nuts	12

Protected under one or more of these U.S. Patent numbers: 3,291,432 3,559,942 3,724,798 DES.270,689 4,613,109 4,878,645 4,852,842 DES.309,562 4,973,023 5,169,114 5,255,884 5,310,152 5,522,576 5,621,614 Re.35,677 DES.398,834 5,826,384 5,941,492 5,964,068 6,060,661 6,102,398

PLATFORM ASSEMBLY

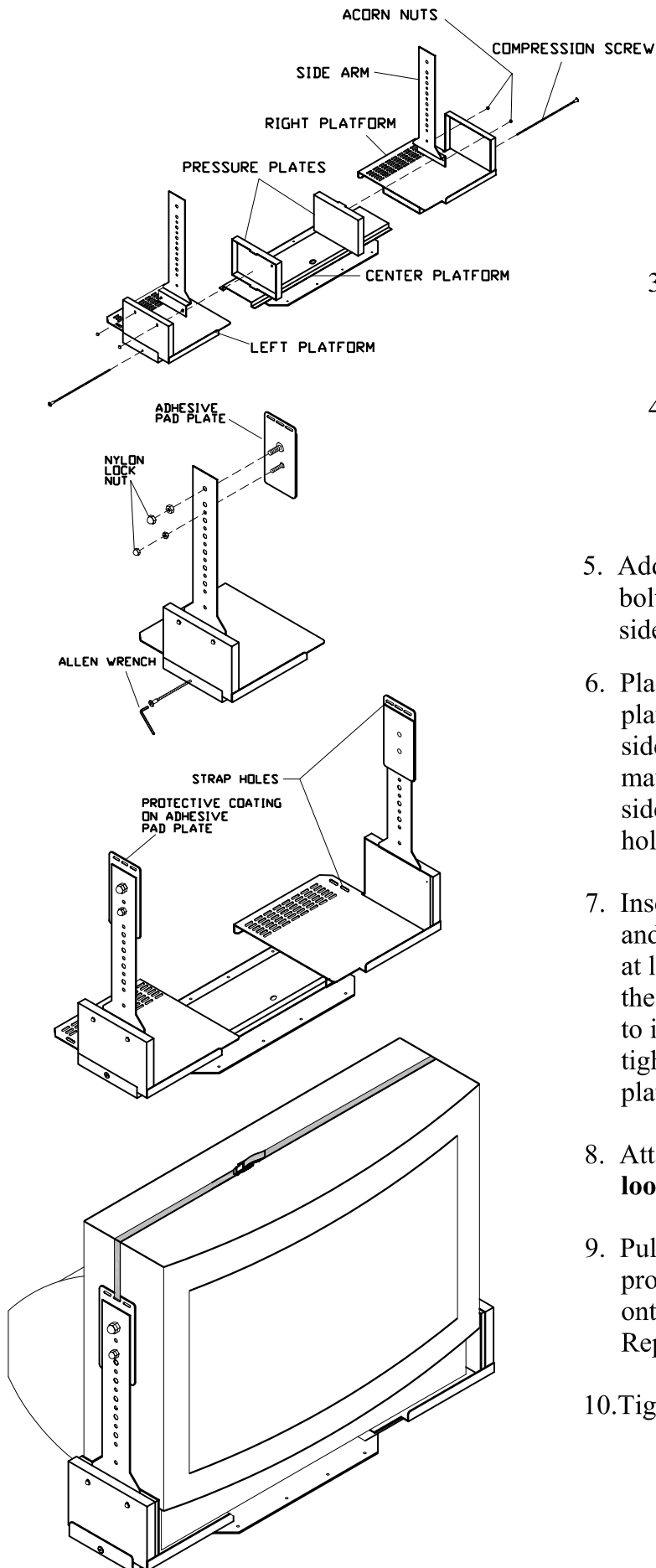

1. Attach the side arms to the left and right side platforms with the four acorn nuts.

2. Insert pressure plates into left and right side platforms.

3. Adjust platform width to receive monitor. Position side arms an equal distance from center hole of platform.

4. Place the adhesive pad plates in sidearm holes at the top of the side arms.

DO NOT REMOVE PLASTIC COVERING FROM ADHESIVE PADS UNTIL STEP 9.

5. Add the 1/2-13 nylon lock nuts and knobs onto the bolts of adhesive pad plates protruding through sidearm.

6. Place monitor on platform. Move the sides of the platform inward until the pressure plates contact the sides of the monitor (if necessary a rubber mallet may be used to force the side plates inward). Be sure side platforms are an equal distance from the center hole in center plate.

7. Insert the compression screws into the side plates and tighten until the rubber pads have compressed to at least 50% of their original thickness and they hold the monitor secure. Rock the monitor back and forth to insure the monitor is secure and the clamps are tight enough. If the monitor slips loosen the side plates reposition the monitor and retighten.

8. Attach Safety Strap as shown in **ST20** instructions **loosely**.

9. Pull one of the side arms outward and peel the protective coating from adhesive pad. Press side arm onto side of monitor to adhere adhesive to monitor. Repeat this step with other side arm.

10. Tighten Safety Strap.