



**LC4X4DS2 - Wall Mount with Articulation for up to 65" Flat Screens with 400mm Mounting Patterns**

The LC4X4DS2 articulating wall mount is designed to use with flat screens from 20" - 65" weighing up to 75lbs. The mounts multi-position triple pivoting arms allows the screen to be positioned in hard to reach areas. Mounts to structures with 16"  $\varnothing$  wall studs or concrete. Once installed, the screen can be pushed into or pulled away from the wall as needed up to 24". The viewing angle can be adjusted  $\pm 45^\circ$  for the best viewing angle.

The VESA<sup>®</sup> mounting patterns on the front of the LC4X4DS2 allow it to be mounted to screens that have mounting patterns of 400mm x 400mm, 400mm x 300mm or 400mm x 200mm.

The mount has convenient cutouts for electrical and A/V wiring to the back of the screen and to the wall.

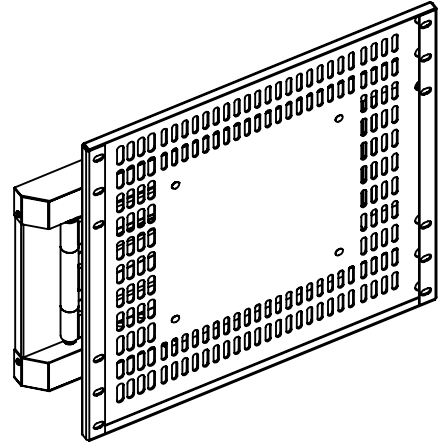

**Features:**

Durable gloss black baked on powder coat finish

For use with flat screens from 20" to 65" weighing under 75lbs (34.1kg)

Fits flat screens with 400mm x 400mm, 400mm x 300mm & 400mm x 200mm VESA<sup>®</sup> mounting patterns

Open pattern wall plate allows for access holes to be cut into the wall for wiring behind the screen

Includes covers to conceal wall attaching hardware

**Optional Accessories:**

LCAPDVD - Accessories for hanging equipment below monitor.

WMATB6 - Toggle Bolt Kit for Metal Studs

WMAAB6 - Concrete Anchor Bolt Kit

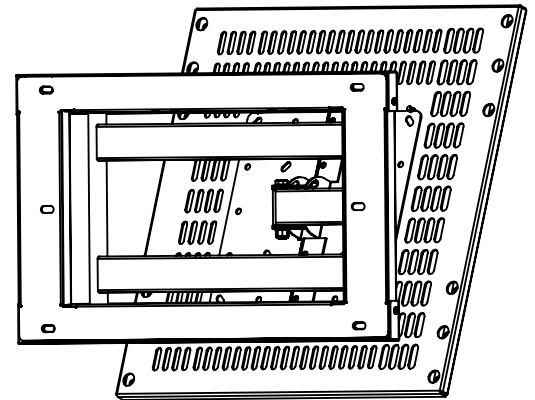

**Maximum Load Limit:**  
75lbs (34.1kg)

**Product Weight:**  
21.0lbs (9.5kg)

**Shipping Weight:**  
22.0lbs (10.0kg)

**Carton Dimensions:**  
21"L x 18"W x 5"H



QR Code Link to  
LC4X4DS2 Web Page

Architectural Specification: The Articulating Wall Mount shall be Lucasey model LC4X4DS2 and shall be located where indicated on the plans. It shall feature monitor attaching plates included compatible with a VESA 400mm x 400mm, 400mm x 300mm or 400mm x 200mm mounting pattern. Assembly and installation shall be done according to instructions provided by the manufacturer.



**Wall Mounting Frame**

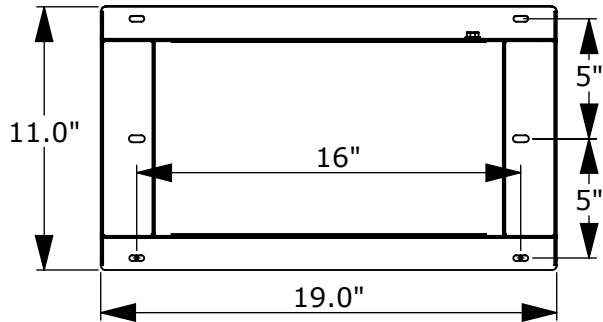

**Front View**

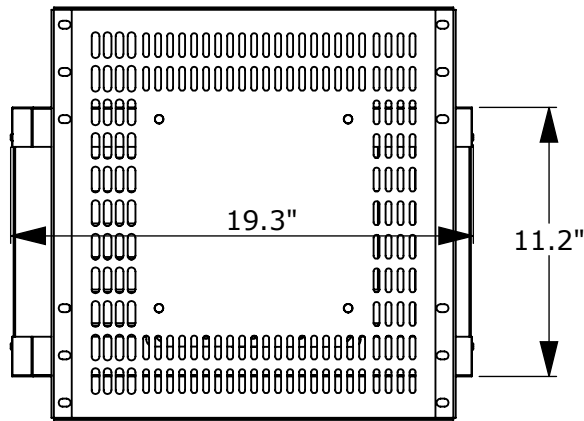

**VESA Mounting Plate**

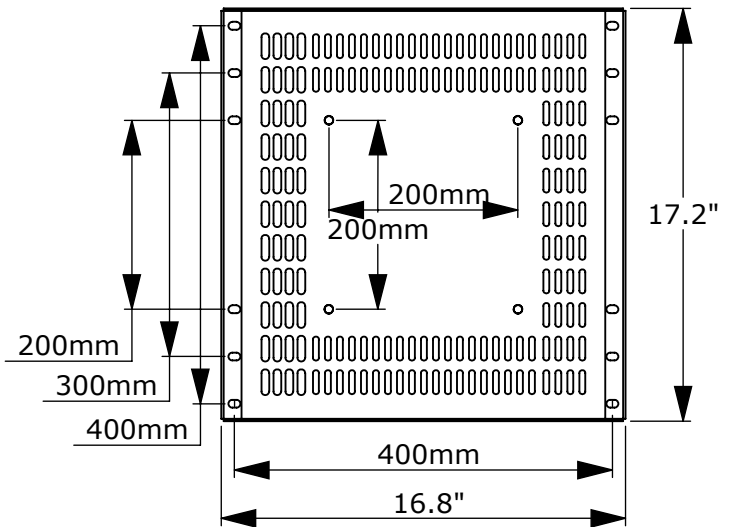

**Top View (Fully Retracted)**

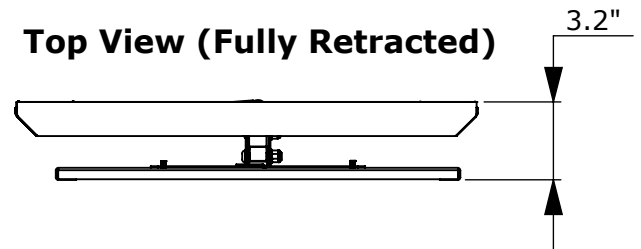

**Top View (Fully Extended)**

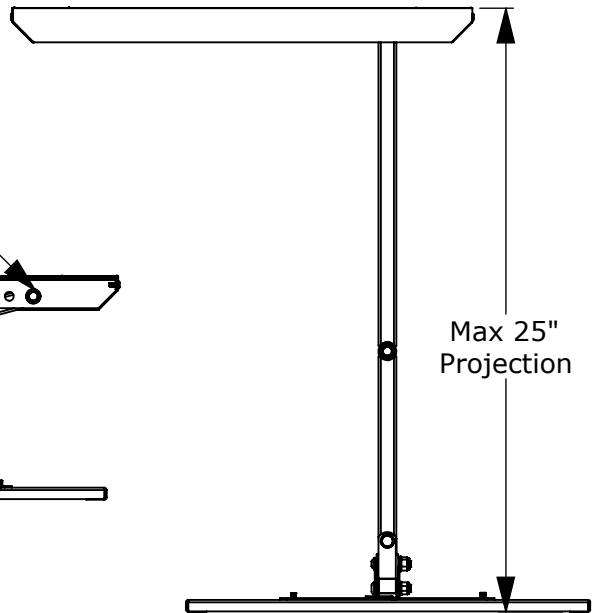

**Side View**

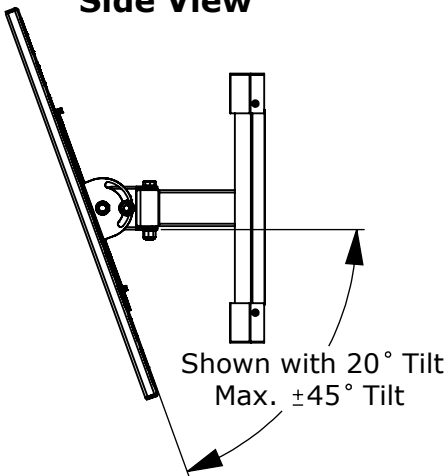

**Top View**

Pivot point for articulation  
(Can be relocated for best monitor viewing location)

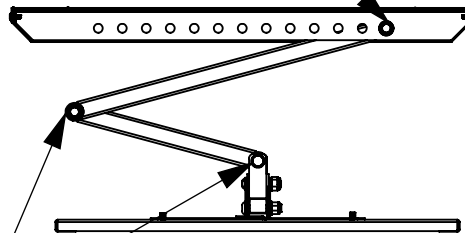

Pivot points for articulation