



LC200WA2 - Articulating Wall Mount for Flat Screens up to 50lbs VESA 100mm & 200mm Mounting Patterns

The LC200WA2 attaches to small and medium size flat screens up to 50lbs with 100mm or 200mm mounting patterns. The two pivot points at the wall and behind the monitor allow the monitor to be articulated from the wall and pivoted from left to right for the optimum viewing angle. The mount allows for tilt adjustment both up and down $\pm 45^\circ$. Wood lag screws are provided for quick and easy installation into a single wall stud.

Features:

Available in black and silver finishes

Universal mounting pattern fits 100mm & 200mm VESA compatible monitors

Articulates into and out from the wall

Pivots behind monitor for left to right viewing angle adjustment

Tilts up and down up to $\pm 45^\circ$

4mm, 5mm & 6mm monitor attaching hardware screws and studs are included

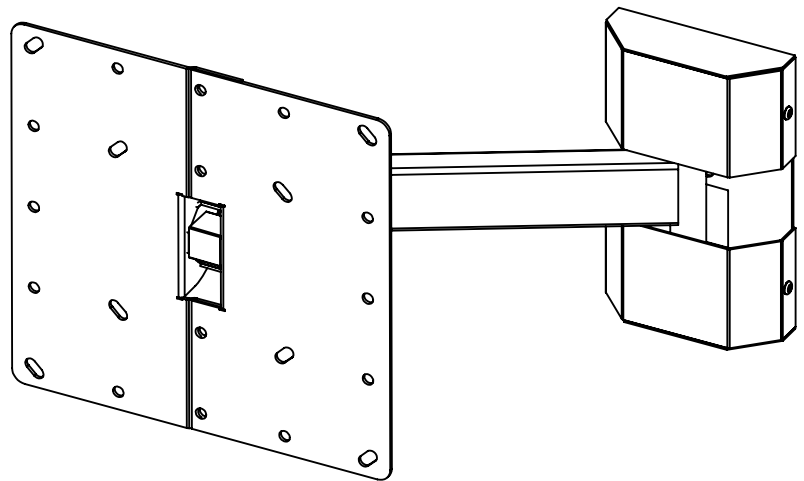

Optional Accessories:

WMATB3 - Metal Stud Toggle Bolt Kit

WMAAB3 - Concrete Anchor Bolt Kit

LCAPDVD2 - Hanging DVD Mount

Maximum Load Limit:

50lbs (22.7kg)

Product Weight:

4.8lbs (2.2kg)

Shipping Weight:

6.3lbs (2.9kg)

Carton Dimensions:

15"L x 12"W x 4"H

Architectural Specification: The Articulating Wall Mount shall be Lucasey model LC200WA2 and shall be located where indicated on the plans. It shall feature monitor attaching plates included compatible with VESA 100mm and 200mm mounting patterns. Assembly and installation shall be done according to instructions provided by the manufacturer.



VESA Mounting Plate

Wall Plate

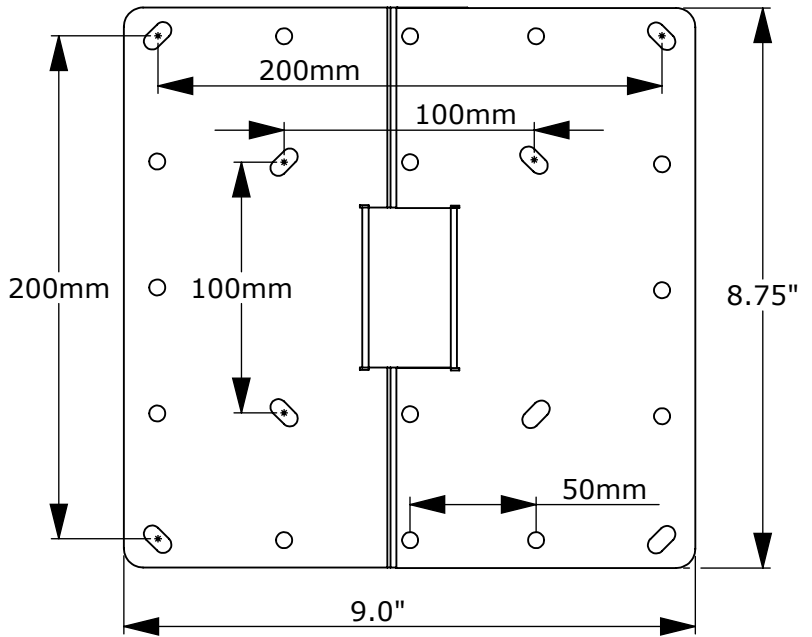
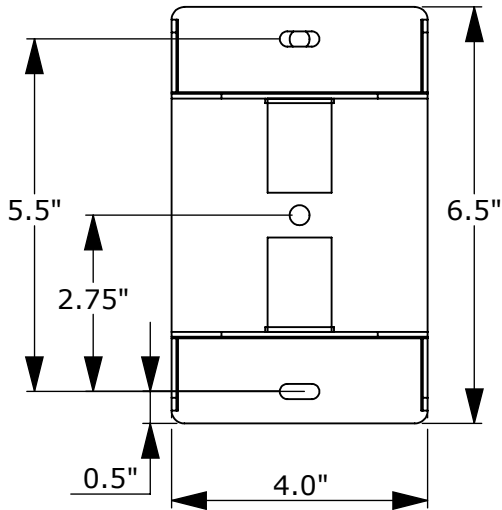

Side View

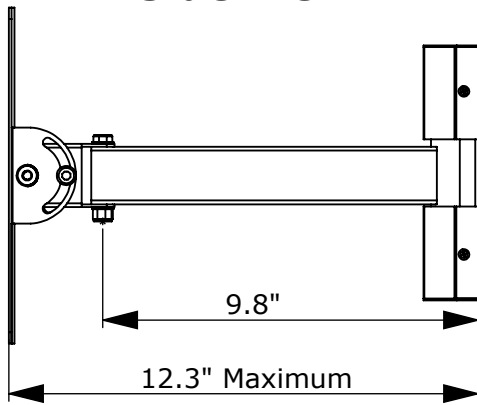

Tilted Side View

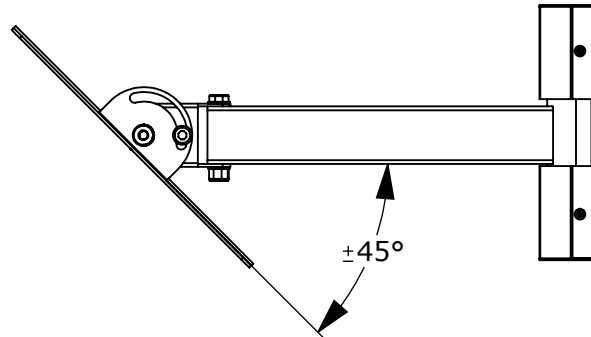

Max. tilt restricted by monitor size and/or distance from the wall

Top Views

