

LC200F9F Furniture Mount for Flat Screens up to 50lbs
with 100mm or 200mm Mounting Patterns

The LC200F9F attaches to small and medium size flat screens up to 50lbs with 75mm, 100mm or 200mm mounting patterns. Countersunk wood tapping screws are provided for quick and easy installation onto the furniture counter top.

Features:

Gloss black baked on finish

Fits from flat screens up to 50lbs

Universal mounting pattern fits 100mm & 200mm VESA compatible monitors

4mm, 5mm & 6mm monitor attaching hardware screws and studs are included

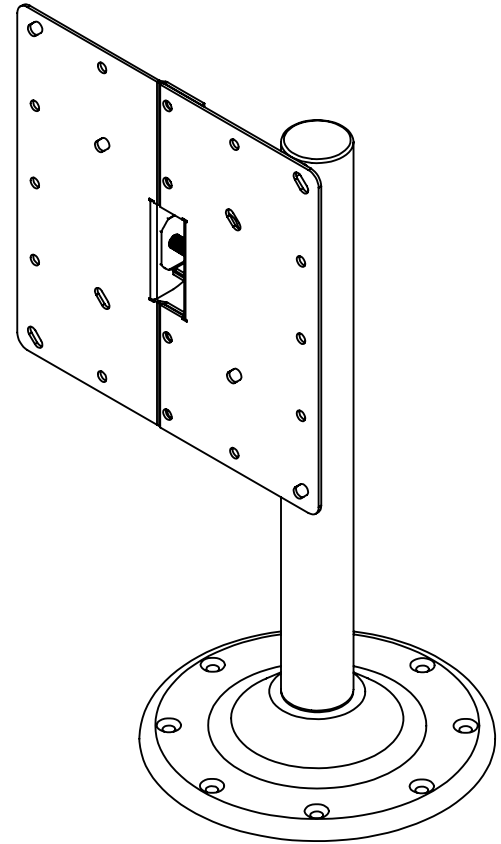

Optional Accessories:

LCAPDVD - Adapter for hanging DVDs, DVRs and other equipment below the flat screen

Maximum Load Limit:

50lbs (22.7kg)

Product Weight:

10.5lbs (4.8kg)

Shipping Weight:

11.2lbs (5.1kg)

Carton Dimensions:

18"L x 10"W x 6-1/2"H

Architectural Specification: The Furniture Mount shall be Lucasey model LC200F9F and shall be located where indicated on the plans. It shall feature monitor attaching plates included compatible with VESA 100mm and 200mm mounting patterns. Assembly and installation shall be done according to instructions provided by the manufacturer.



Round Base

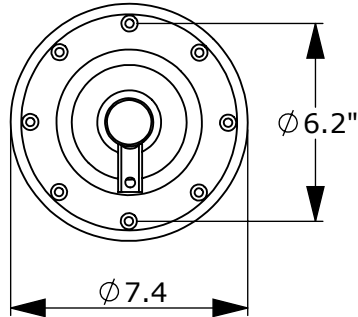

Top View

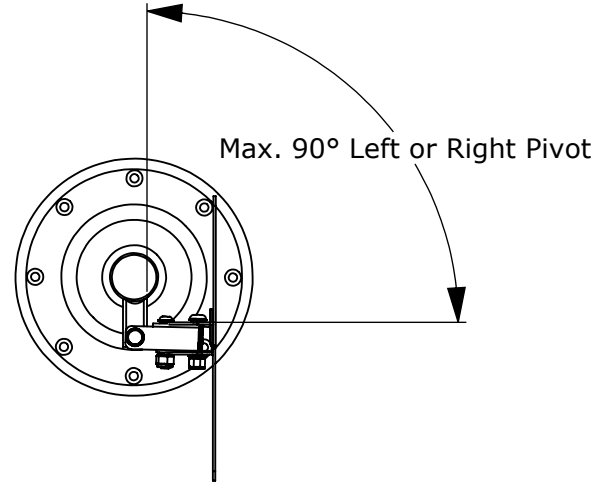

Front View

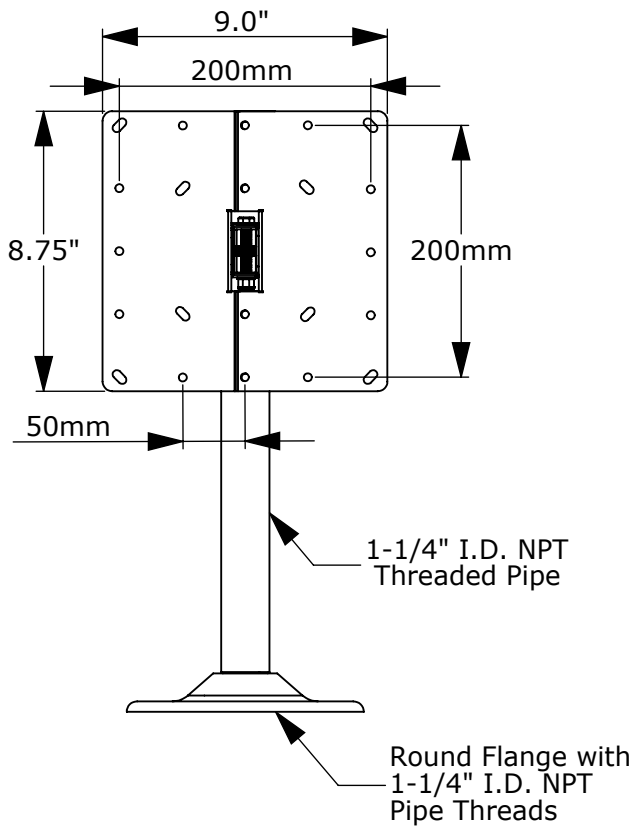

Side Views

