

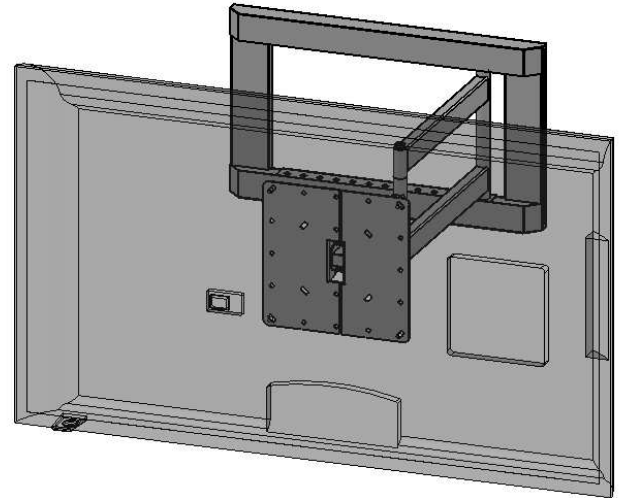

LC200DS2 - Articulating Wall Mount for Flat Screens up to 65" with 200mm or 100mm VESA[®] Mounting Patterns

The LC200DS2 Multi-position triple pivoting arms allows the monitor to be positioned in hard to reach areas. Use the LC200DS2 with 20" - 65" flat screens weighing up to 75 Pounds. Ideal for concealing cord connections in the wall behind the flat screen. Designed to mount to structures with 16" \varnothing wall studs. The monitor can be pushed into or pulled away from the wall as needed. The viewing angle can be adjusted $\pm 45^\circ$ for the best viewing position.



Features:

Durable gloss black baked on powder coat finish

Fits 20" - 65" flat screens up to 75lbs with 200mm x 200mm, 200mm x 100mm or 100mm x 100mm VESA[®] mounting patterns

Open pattern of wall plate allows access holes to be cut into wall for wiring behind monitor.

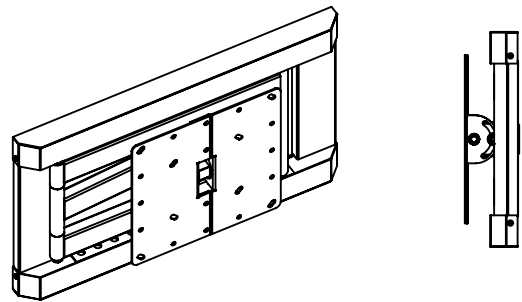

Optional Accessories:

WMATB6 - Toggle Bolt Kit for Metal Studs

WMAAB6 - Concrete Anchor Bolt Kit



LC200DS2 QR Code
Link to Web Page

Maximum Load Limit:

75lbs (34.1kg)

Product Weight:

13.3lbs (6.0kg)

Shipping Weight:

15.3lbs (7.0kg)

Carton Dimensions:

21"L x 13-1/2"W x 4"H

Architectural Specification: The Articulating Wall Mount shall be Lucasey model LC200DS2 and shall be located where indicated on the plans. It shall feature monitor attaching plates included compatible with 200mm x 200mm, 200mm x 100mm or 100mm x 100mm mounting patterns. Assembly and installation shall be done according to instructions provided by the manufacturer.



Top View (Fully Extended)

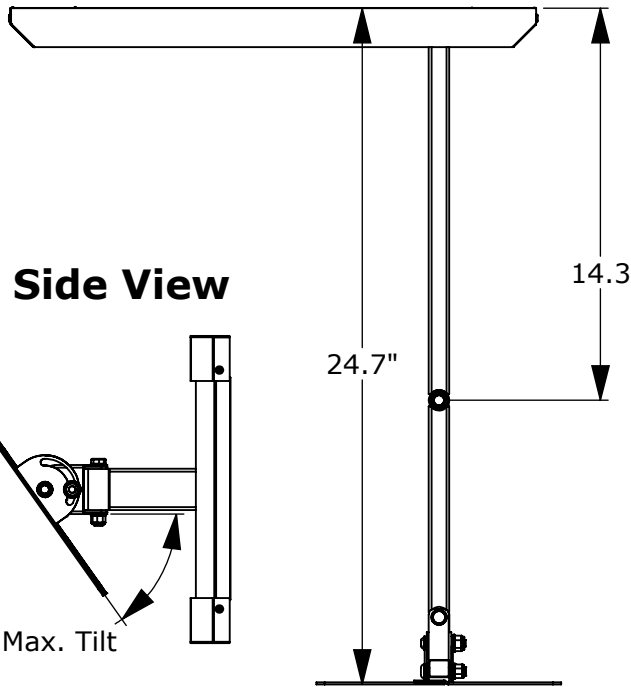

Side View

VESA Mounting Plate

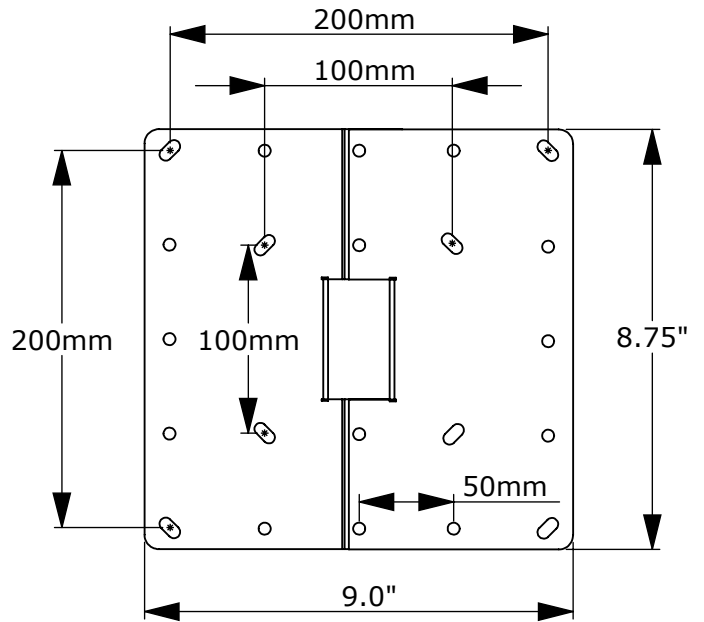

Front View

Top View (Fully Retracted)

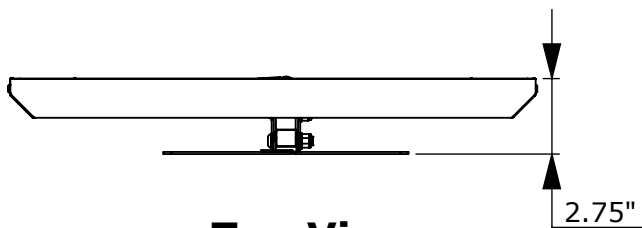

Top View

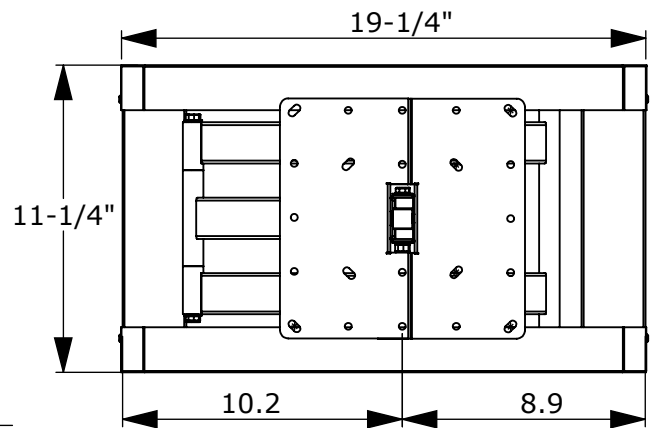

Pivot point for articulation
(Can be relocated for best monitor viewing locaiton)

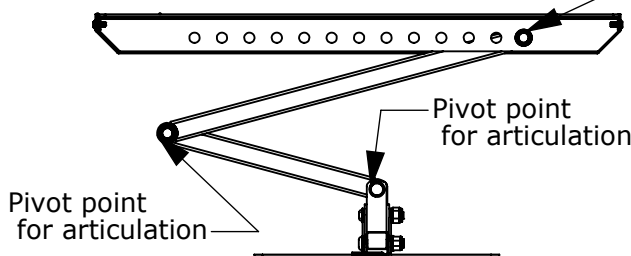

Wall Mounting Frame

