

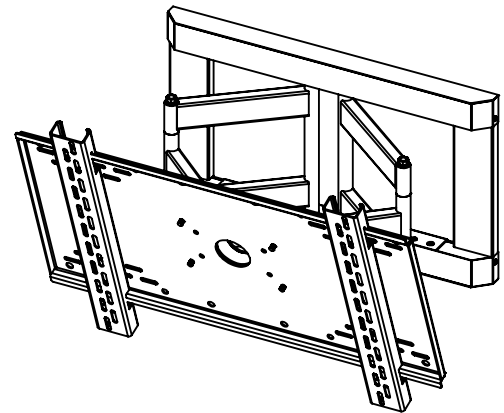

**FSWADS2TUL2014**    Articulating Wall Mount for up to 65"  
Flat Screens weighing up to 125lbs

The FSWADS2TUL2014 articulating wall mount has multi-position dual articulating arms that can hold 20"-65" flat screens up to 125 Pounds. The open wall frame is ideal for concealing cord connections in the wall behind the flat screen. Designed to mount to structures with 16"  $\varnothing$  wall studs. The monitor can be pushed into or pulled away from the wall as needed. The dual pivot points and relocatable wall arm position allow for flexibility in monitor placement. The monitor can be pivoted up to 90° Left or Right and tilted up to 20° for the best viewing angle. Wood lag screws are provided for wood stud installations. The mount includes an adapter plate fitting mounting patterns between 20" Wide by 14" Tall including standard VESA® mounting patterns.

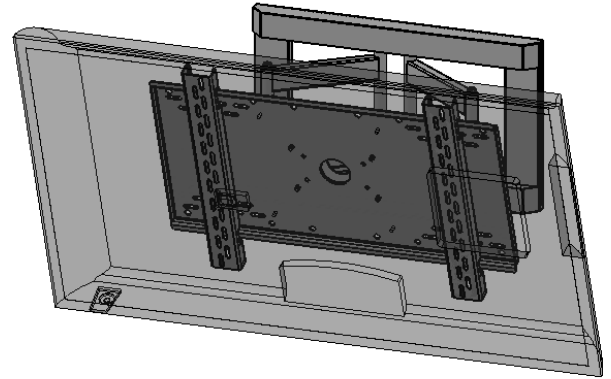

**Features:**

Durable black baked on powder coat finish

Fits 20" - 65" flat screens weighing less than 125lbs

Fits all flat screens with mounting patterns up to 20" wide and 14" tall including the following VESA® mounting patterns: 400mm x 200mm, 400mm x 300mm, 300mm x 300mm, 200mm x 200mm, 200mm x 100mm & 100mm x 100mm

**Optional Accessories:**

WMATB6 - Metal Stud Toggle Bolt Kit

WMAAB6 - Concrete Anchor Bolt Kit



FSWADS2 QR Code  
Link to Web Page

**Maximum Load Limit:**

125lbs (56.8 kg)

**Product Weight:**

24.0lbs (10.9 kg)

**Shipping Weight:**

26.5lbs (12.1 kg)

**Carton Dimensions:**

24"L x 13"W x 4"H

Architectural Specification: The Articulating Wall Mount shall be Lucasey model FSWADS2TUL2014 and shall be located where indicated on the plans. The FSWADS2TUL2014 shall include including monitor attaching channels compatible with the monitors mounting pattern. Assembly and installation shall be done according to instructions provided by the manufacturer.



**Wall Plate**

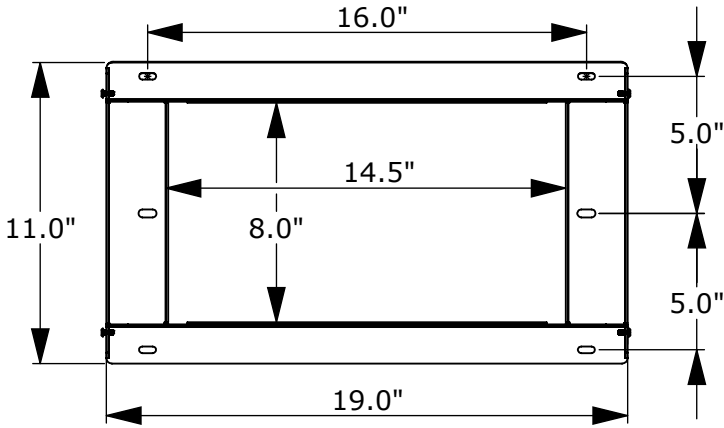

**Side View with Tilt**

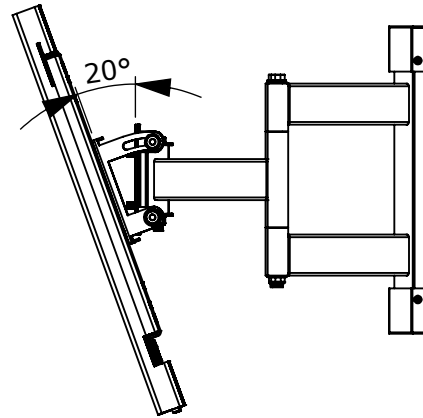

**Front View**

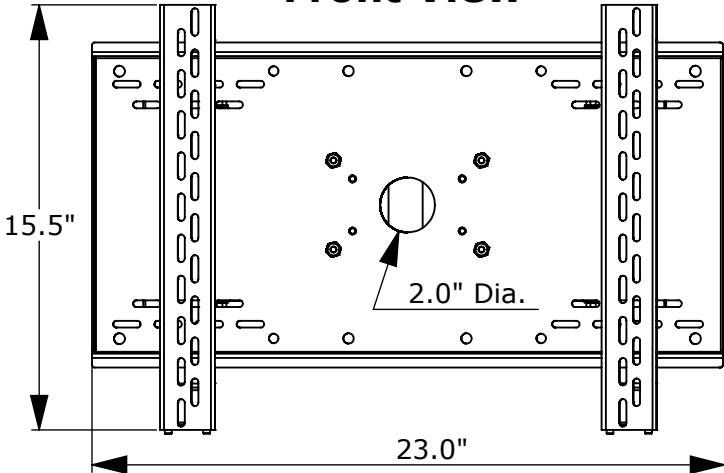

**Top View Retracted**

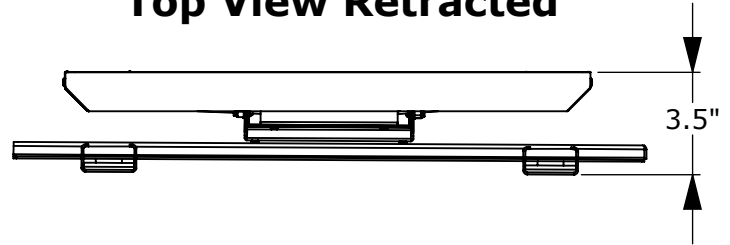

**Top View with Pivot**

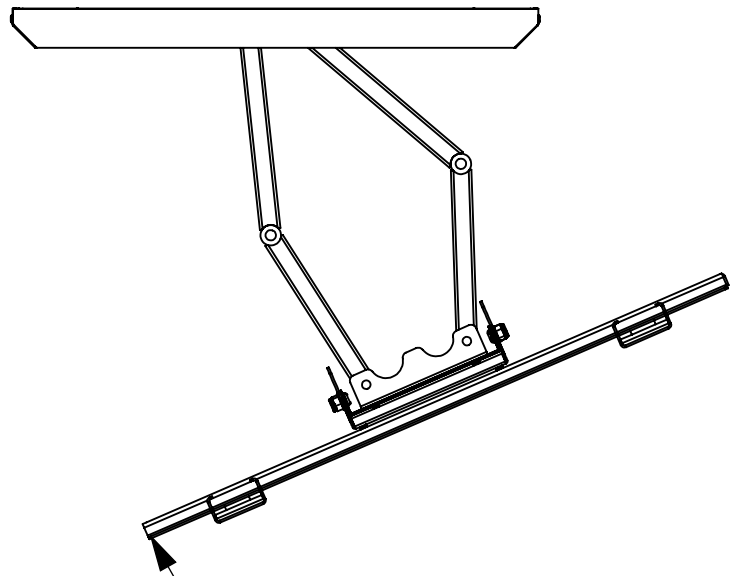

**Top View Extended**

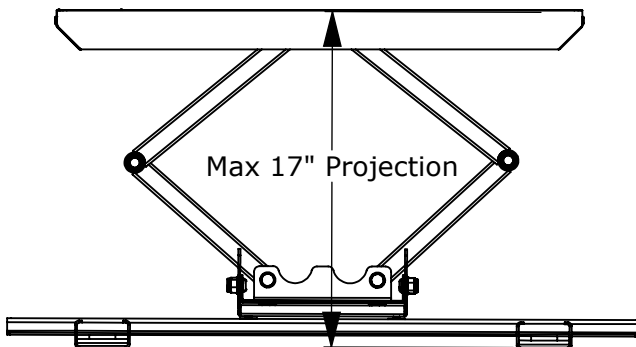

Pivots left and right is limited by the size of monitor and projection from the wall