



FSCTD Dual Back to Back Ceiling Mount
for Two Flat Screens up to 200lbs

Ceiling mount with two back to back monitors with tilt. Both monitors can swivel 360°. Fits two monitors that weigh less than 100lbs. each and uses 100mm x 100mm, 200mm x 100mm, 200mm x 200mm or 300mm x 300mm VESA® mounting patterns. Also fits monitors with non-VESA® mounting patterns using a universal FSUL or FSUP adapter plate (sold separately). Mounts to a 1-1/2" I.D. ceiling flange (sold separately) bolted to the ceiling structure. Several varieties of ceiling flanges are available for different types of ceiling structures (see mount accessories).

Features:

Durable baked on epoxy black wrinkle finish

Fits two flat screen monitors up to 100lbs each

Compatible with: FSA, FSUL & FSUP flat screen adapters.

Fits 100mm x 100mm, 200mm x 100mm, 200mm x 200mm or 300mm x 300mm VESA® mounting patterns

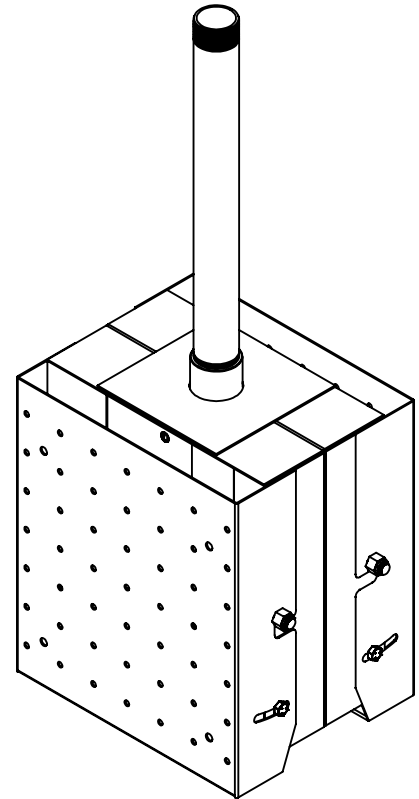

Optional Accessories:

CMASF150 - Square Heavy Duty Ceiling Flange

CMAF150 - Custom Cut Pipe Threaded and Powder Coated

CMAEF150 - Chrome Escutcheon Flange

Maximum Load Limit:

200lbs (90.9 kg)

Product Weight:

40lbs (18.2 kg)

Shipping Weight:

42lbs (19.1 kg)

Carton Dimensions:

20"L x 15"W x 12"H

Architectural Specification: The Dual Back to Back Ceiling Mount shall be Lucasey model FSCTD and shall be located where indicated on the plans. The mount will fit VESA mounting patterns of 100mm, 200mm or 300mm or shall be used with two universal or model specific monitor attaching adapter plates compatible with monitor models specified. Ceiling attaching hardware and accessories shall be specified separately. Assembly and installation shall be done according to instructions provided by the manufacturer.



Front Plate

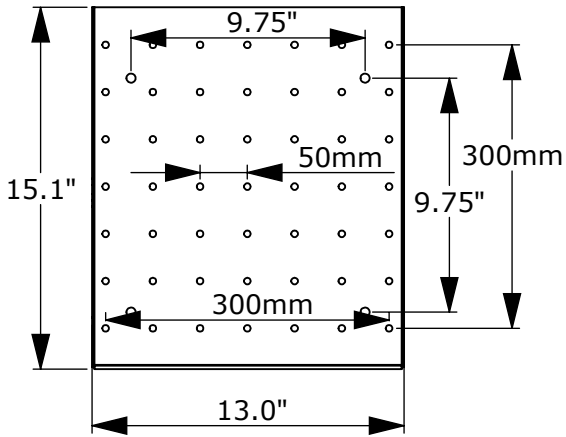

Top View

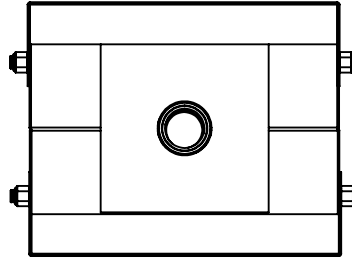

Bottom View

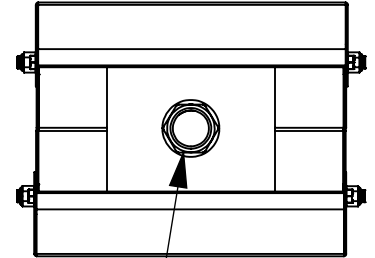

360° Rotation

Front View

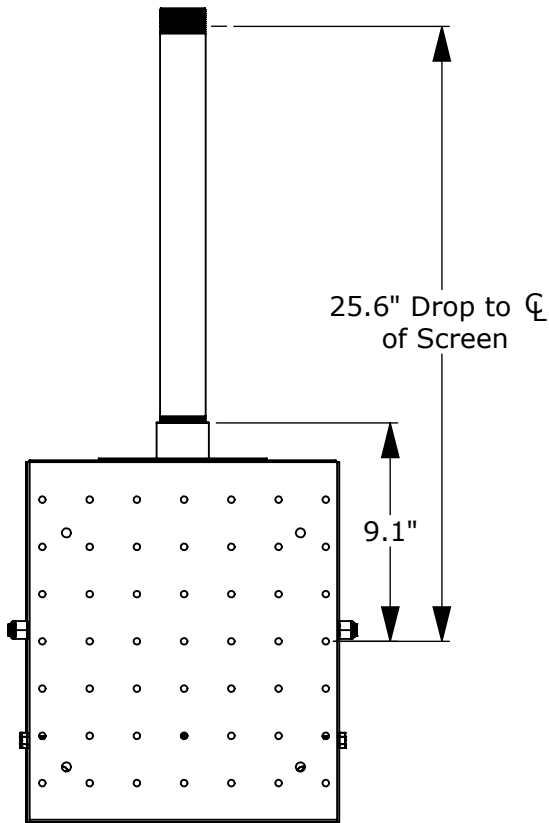

Side Views

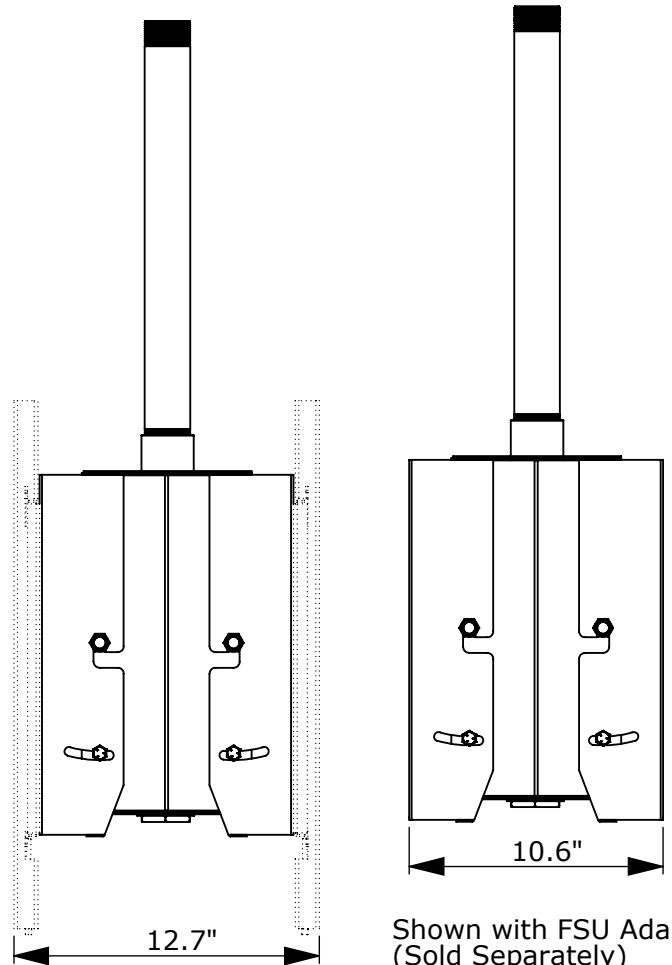

Shown with FSU Adapters
(Sold Separately)