

Contour and Surface Roughness Measuring System FORMTRACER CS-3200

Bulletin No. 1958



Double performance in one system:
combined contour and surface measurement
machine delivers high accuracy, high speed and
simplified CNC measurement.

Mitutoyo

A Rich Choice of Functions to Enhance Your Measurement Efficiency

Featuring a wide measuring range and high-resolution detector, many kinds of measurement from contours to surface roughness are covered. Single-unit measurement reduces setup labor and measurement time.

Wide measuring range and high-resolution detector

Measuring range (Z-axis): 0.19" (3.15 μ m resolution) to 0.0019" (0.0315 μ m resolution)
(5mm (80nm resolution) to 0.05mm (0.8nm resolution))

Accuracy (Z-axis): $\pm(60+|20H|)\mu$ m ($\pm(1.5+|2H|/100)\mu$ m,) H = Height from horizontal plane inch (mm)



Mitutoyo

● **Conventional measurements...**

STEP 1 Contour measurement STEP 2 Surface roughness measurement



with CS-3200

Surface roughness measurement involves setting up the machine again with a different detector.

Enhanced Measurement Efficiency



Single setup and single tracing - no detector change

● **Conventional measurement space needed...**

Contour measuring instrument

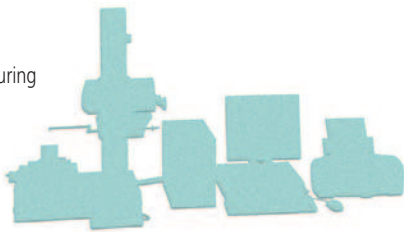

Surface roughness measuring instrument

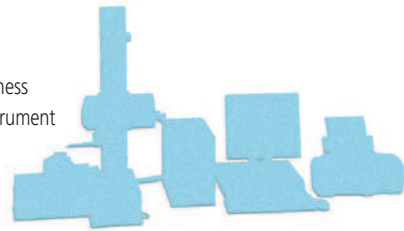

with CS-3200

Space for 2 measuring instruments, in addition to 2 PCs and 2 printers.

Space-saving



Space for just a single measuring instrument

● **Conventional printed results...**

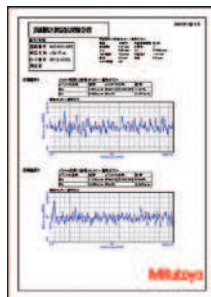
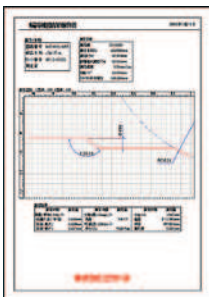

with CS-3200

Contour measuring instrument and surface roughness measuring instrument print measurement data individually.

Resource-saving

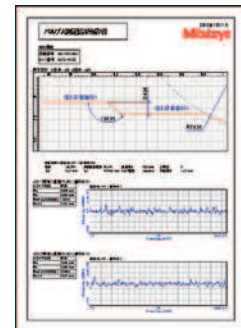

One inspection certificate printed with a minimum amount of paper, using a single printer and reducing energy requirements

Highly accurate linear encoders on X/Z2-axis

The drive unit (X-axis) and column (Z2-axis) are equipped with high-accuracy linear scales (ABS type) enabling fully automatic measurement combining vertical and horizontal movement.

This improves reproducibility of continuous automatic measurement of small holes in the vertical direction and repeated measurement of parts which are difficult to position.

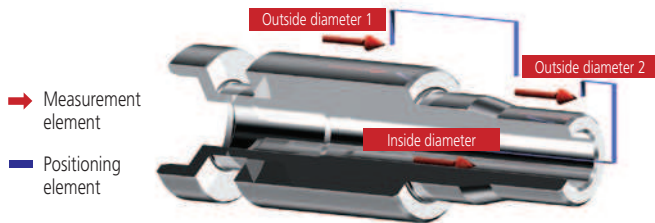

Continuous measurement example
(Outside diameter 1 → Outside diameter 2 → Inside diameter)

Improved measurement efficiency

Dramatically increased drive speed (X-axis: 80mm/s, Z2-axis: 20mm/s) further reduces total measurement time. Small holes can be efficiently measured using the fine-feed knobs on the X- and Z2-axes.



Small hole measurement example



Y- and Z-axis positioning using column (Z2-axis) fine-feed knob or cross-travel table (optional)



Measurement start positioning by (X-axis) fine-feed knob

Advanced design

The detector unit can be extended to avoid interference between the drive unit and workpiece.

All detector and drive unit cables are housed inside the main unit to eliminate any risk of abrasion and guarantee trouble free, high-speed operation.



Drive unit tilting function and air vibration-damping stand are standard features.

Drive unit (X-axis) tilting function powerfully supports measurements on inclined planes and for heavy workpieces that are not easily moved.



Software, FORMTRACEPAK6000

MiCAT

Mitutoyo Intelligent Computer Aided Technology

the standard in world
metrology software
FORM

FORMTRACEPAK6000 provides a wide range of support, including measuring instrument control, contour analysis, surface roughness analysis, design data creation, contour verification, and inspection certificate creation functions!

Various functions are available to meet the needs of every department, including simplified repetitive measurements conducted by inspection departments and thorough pursuit of surface texture enhancement by R&D departments.

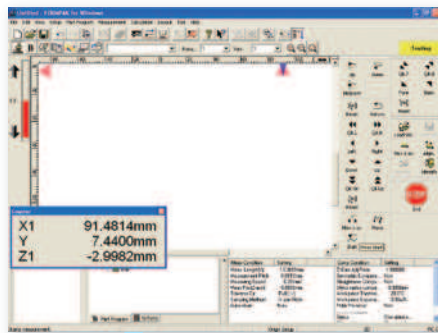

Measuring instrument control

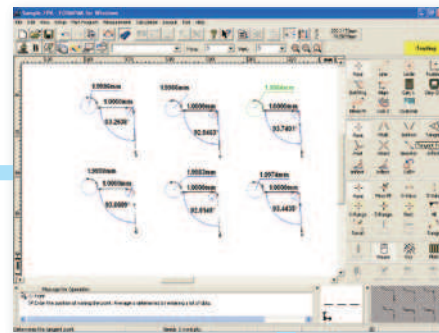

Contour analysis

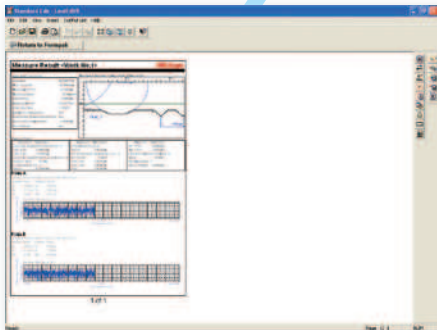

Inspection certificate creation

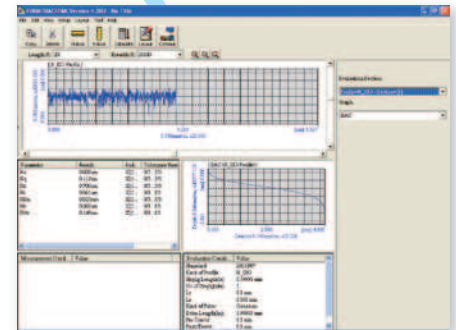

Surface roughness analysis

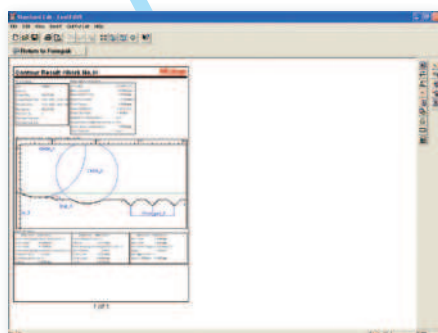

Contour verification

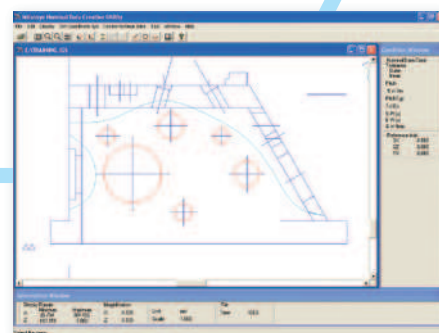

Design data creation (CAD file import)

Software, FORMTRACEPAK6000

Measurement control

- All the command icons necessary for executing or creating a measurement procedure (part program) are laid out on the measurement control screen. Any unused icon and display area can be displayed or hidden arbitrarily, allowing the operator to customize the screen layout for ease of use.
- A measurement procedure can be easily invoked by selecting it from the pull-down menu.

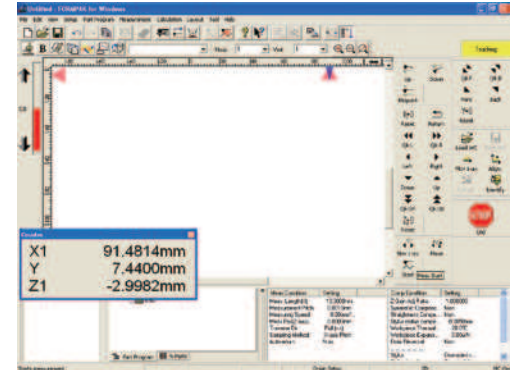
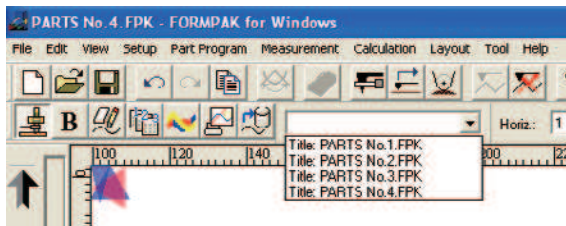

Contour analysis function

- Various commands including point (10 kinds), line (6 kinds), and circle (6 kinds) are provided to cover the basic elements of analysis. Standard calculation commands that combine these elements for angle, pitch or distance calculation are also provided. The display can be tailored by the customization function to suit the application. For example, the calculation command can be hidden to simplify the measurement environment.
- With the useful Automatic Circle/Line Application command it is possible to automatically calculate all circles and lines that are included in the data without pressing the command button many times over.
- The Outlier Removal Function is very useful, for example, to automatically remove irregular flaws from the data and set the calculation range for sections where the boundary between a circle and a line cannot be easily identified.
- Calculation results are output as text (in csv or/and txt format). Geometrical measurement data can be either output as point-series data into a text file or CAD file (in DXF or IGES format) or copied onto the clipboard. It is also possible to use some commercial documentation software and statistical processing software to share the data on a PC that is not installed with the Mitutoyo-original analysis software, or where reverse engineering with CAD is intended.

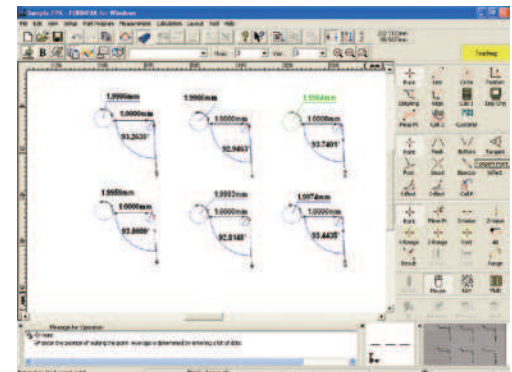

Surface roughness analysis function

- Analysis conforming to global roughness standards: ISO, JIS ('82, '94, '01), ANSI and VDA, etc.
- In addition to parameter calculation, various graph analysis functions are available. Can be widely used for daily quality control, in addition to use in R&D departments.
- There are also various data correction (inclination, curved surface) and deletion functions provided.

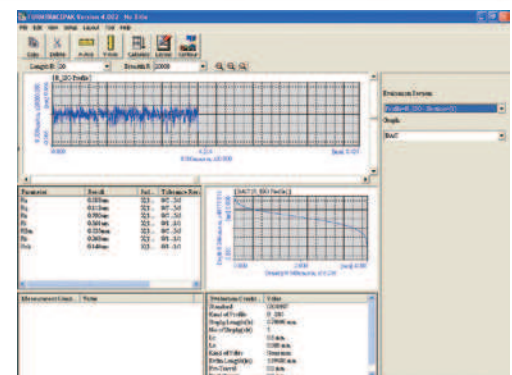
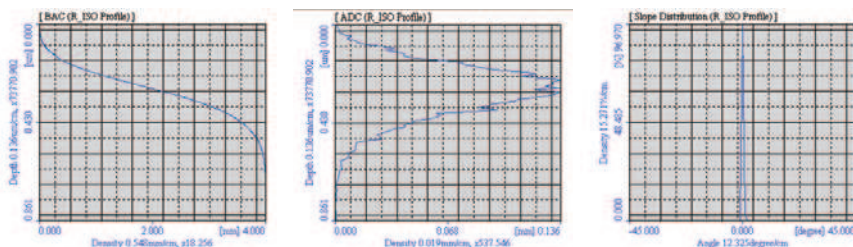

Optional Accessories for Automatic Measurement

Y-axis table: No. 178-097

Enables efficient, automatic measurement of multiple aligned workpieces and multiple points on a single measurement surface.

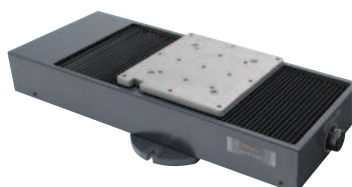

Travel range	7.87" (200mm)
Resolution	0.05μm
Positioning accuracy	±3μm
Drive speed	Max 80mm/s
Maximum load	110 lbs (50kg)
Mass	61.73 lbs (28kg)

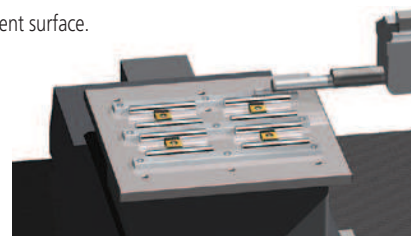

Rotary table / θ1-axis table: No. 12AAD975

For efficient measurement in the axial/transverse directions. When measuring a cylindrical workpiece, automatic alignment can be performed in combination with the Y-axis table. (θ1-axis mounting plate (12AAE630) is required when directly installing on the base of the CS-3200.)



Displacement	360°
Resolution	0.004°
Maximum load	26.45 lbs (12kg)
Rotational speed	Max10°/s
Mass	15.4 lbs (7kg)

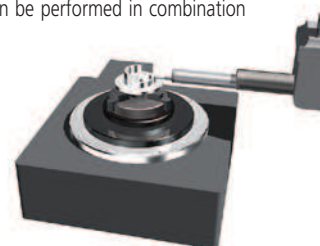

Rotary table / θ2-axis unit: No. 178-078

You can measure multiple points on a cylindrical workpiece and automate front/rear-side measurement. (θ2-axis mounting plate (12AAE718) is required when directly installing on the base of the CS-3200.)

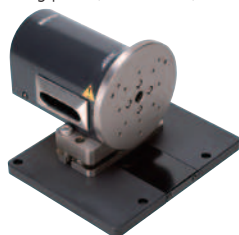

Displacement	360°
Resolution	0.0072°
Maximum load (loading moment)	8.8 lbs (4kg) (343 N·cm or less)
Rotational speed	Max18°/s
Mass	11 lbs (5kg)

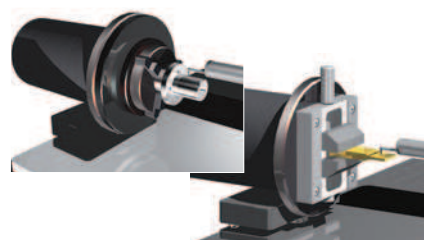

Quick chuck: No. 211-032

This chuck is useful when measuring small workpieces. You can easily clamp them with its knurled ring.



Retention range	Inner latch: OD ø0.4" to ø1.42" (ø1 to ø36mm)
	Inner latch: ID ø0.55" to ø2.76" (ø14 to ø70mm)
	Outer latch: OD ø0.04" to ø2.95" (ø1 to ø75mm)
Dimensions (D x H)	ø4.64" x 1.61" (ø118x41mm)
Mass	2.65 lbs (1.2kg)

Micro-chuck: No. 211-031

This chuck is suitable for clamping extra-small diameter workpieces (ø1mm or less), which cannot be retained with the Quick Chuck.



Retention range	OD ø0 to ø0.06" (ø0 to ø1.5mm)
Dimensions (D x H)	ø4.64" x 1.91" (ø118x48.5mm)
Mass	1.3 lbs (0.6kg)

Auto-leveling table: No. 178-087

This is a platform that performs fully automatic leveling as measurement starts, freeing the user from this troublesome operation. Fully automatic leveling can be completed quickly. In addition, the operation is easy and reliable.



Inclination adjustment angle	±2°
Maximum load	15.4 lbs (7kg)
Table dimensions	5.12" x 3.94" (130x100mm)
Mass	7.7 lbs (3.5kg)

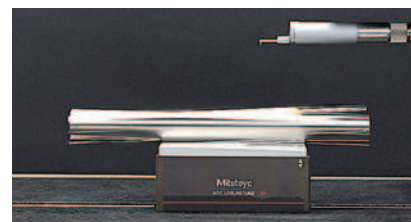

Optional Accessories for Expanding the Application Range

3-axis adjustment table : No. 178-047

This table helps make the alignment adjustments required when measuring cylindrical surfaces. The corrections for the pitch angle and the swivel angle are determined from a preliminary measurement and the Digimatic micrometers are adjusted accordingly. A flat-surfaced workpiece can also be leveled with this table.

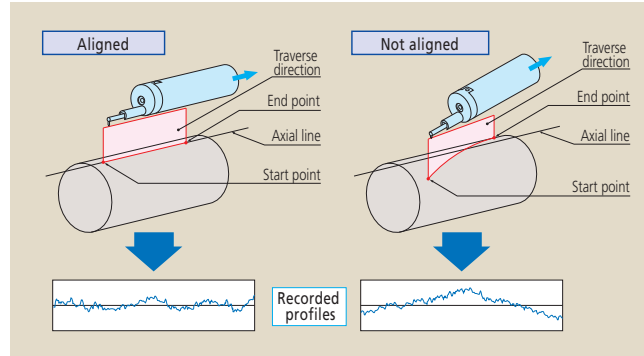
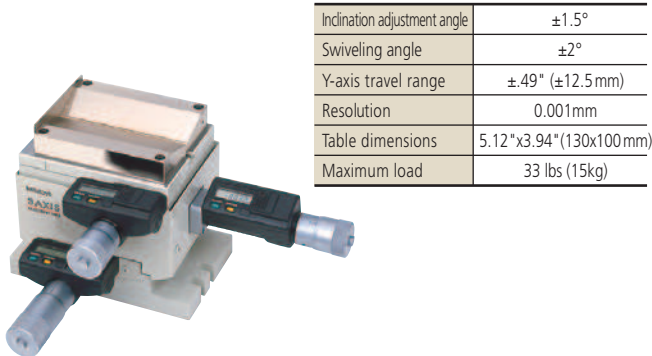

Others

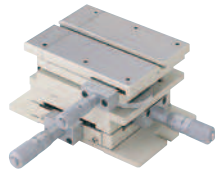

Leveling table with analog heads
178-043-1



Leveling table with digital heads
178-042-1

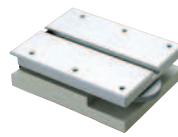

Leveling table
178-016



Calibration stand
12AAG175

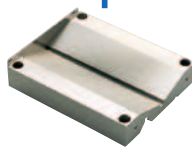

V-block
998291



Precision vise
178-019



Cross-travel table
218-001



Cross-travel table
218-041



Rotary vise
218-003



Center supports
172-142

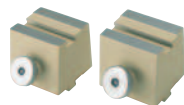

Center support risers
172-143



Swivel center support
172-197



Holder with clamp
176-107



V-block
172-234



V-block w/clamp
172-378

Optional Styli*

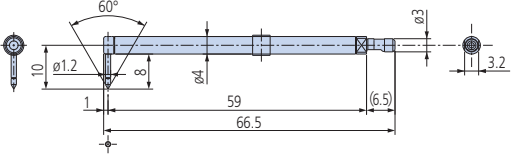
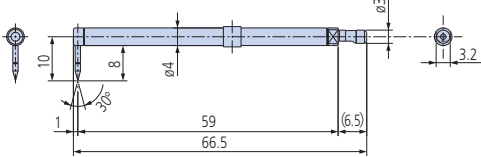
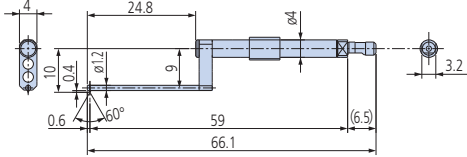
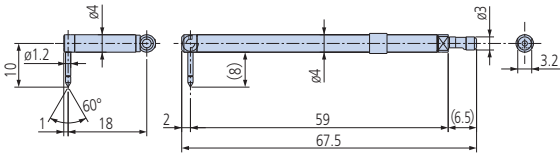
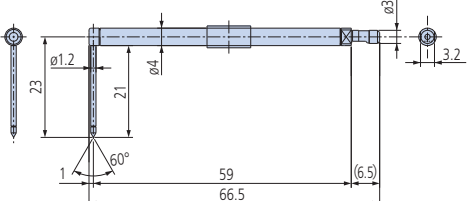
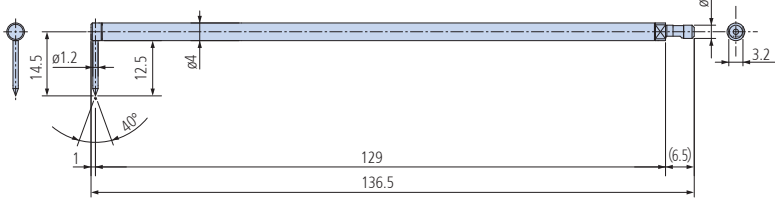
Type	Dimensions	Specifications
Standard stylus (No.12AAD554) Standard accessory		Radius of tip curvature: 78.7 μ m (2 μ m) Tip form: 60° cone Tip material: Diamond For contour/surface roughness measurement Measurable depth: .275" (7mm) max.
Cone stylus (No.12AAD552) Standard accessory		Radius of tip curvature: 984.3 μ m (25 μ m) Tip form: 30° cone Tip material: Sapphire For contour measurement Measurable depth: .275" (7mm) max.
Small hole stylus (No.12AAD556)		Radius of tip curvature: 78.7 μ m (2 μ m) Tip form: 60° cone Tip material: Diamond For contour/surface roughness measurement Applicable hole: 0.07" ϕ (2mm) min. Measurable depth: 0.59" (15mm) max.
Eccentric type stylus (No.12AAD558)		Radius of tip curvature: 78.7 μ m (2 μ m) Tip form: 60° cone Tip material: Diamond For contour/surface roughness measurement Offset from center line: 0.59" (15mm)
Deep groove stylus (No.12AAD560)		Radius of tip curvature: 7.87 μ m (2 μ m) Tip form: 60° cone Tip material: Diamond For contour/surface roughness measurement Measurable depth: 0.78" (20mm) max.
2x-long stylus*1 (No.12AAD562)		Radius of tip curvature: 197 μ m (5 μ m) Tip form: 40° cone Tip material: Diamond For contour/surface roughness measurement

*1: Measuring force is 4mN and the Z1 measuring range and resolution is double that of the standard stylus.

* Styli shown on this page are for the CS-3200 standard detector unit. Cannot be used with contour detector units CV / SV-C 3000/4000 (factory-set options).

Technical information

Model No.	FORMTRACER CS-3200S4	
Order No. (main unit)	525-411A (inch)	
FORMTRACEPAK6000	12AAJ340 (inch/mm)	
Measuring range	X-axis	3.94" (100mm)
	Z1-axis (detector unit)*	0.20" (5mm)
Z2-axis (column) travel	11.8" (300mm)	
X-axis traverse linearity (in horizontal orientation)	8 μ m/4" (16 μ m/4") (0.2 μ m / 100mm (0.4 μ m / 100mm: at the extended detector position)	
Indication accuracy	X-axis	$\pm(32+10L)\mu$ m ($\pm(0.8+0.01L)\mu$ m) L = Drive length inch (mm)
	Z1-axis (detector unit)	$\pm(60+ 20H)\mu$ m $\pm(1.5+ 2H /100)\mu$ m, H = Measurement height from the horizontal position inch (mm)
Resolution	X-axis	1.97 μ m (0.05 μ m)
	Z1-axis (detector unit)*	3.15 μ m [0.19" range], 0.315 μ m [0.019" range], 0.0315 μ m [0.0019" range] (80nm [5mm range], 8nm [0.5mm range], 0.8nm [0.05mm range])
	Z2-axis (column)	39.4 μ m (1 μ m)
Drive speed	X-axis	0 - 3.1"/s and manual (0 - 80mm/s and manual)
	Z2-axis (column)	0 - 0.78"/s and manual (0 - 20mm/s and manual)
Measuring speed	In surface roughness measurement	0.00078, 0.00197, 0.00393, 0.00787"/s (0.02, 0.05, 0.1, 0.2mm/s)
	In contour measurement	0.00078, 0.00197, 0.00393, 0.00787, 0.0197, 0.0393, 0.0787"/s (0.02, 0.05, 0.1, 0.2, 0.5, 1, 2mm/s)
X-axis inclining range	$\pm 45^\circ$	
Measuring direction	Push / Pull	
Face of stylus	Downward	
Traceable angle	$\pm 65^\circ$ (using the standard chisel-cut stylus and depending on the surface roughness)	
Measuring force*	0.75 mN	
Stylus tip	Standard stylus	Tip angle: 60°, Tip radius: 78.7 μ m (2 μ m), Diamond tip (for contour and surface roughness measurement)
	Cone stylus	Tip angle: 30°, Tip radius: 984.3 μ m (25 μ m), Sapphire tip (for contour measurement)
Base size (W x D)	23.6" x 17.7" (600 x 450mm)	
External dimensions (W x D x H)	Main unit	30" x 19" x 38" (756 x 482 x 966mm)
	Vibration isolating stand	32" x 30" x 28" (810 x 755 x 700mm)
	Controller unit	8.7" x 13.5" x 19.3" (221 x 344 x 490mm)
	Remote control box	9.8" x 4" x 2.4" (248 x 102 x 62.2mm)
Mass	Main unit	308.6 lbs (140kg)
	Vibration isolating stand	330.7 lbs (150kg)
	Controller unit	30.86 lbs (14kg)
	Remote control box	1.98 lbs (0.9kg)
Air source (for vibration isolating stand)	Air pressure	8.15 lbs / ft (390kPa)
	Air consumption	30L/day to 50L/day in standard condition

* When using 2x-long stylus (12AAD562)

Z1-axis (detector unit) measuring range: 0.40" (10mm)

Z1-axis (detector unit) resolution / range: 6.3 μ m / .38", 0.63 μ m / 0.038", 0.063 μ m / 0.0038" (160nm / 10mm, 16nm / 1mm, 1.6nm / 0.1mm)

Measuring force: 4mN

Main Unit Startup System

This machine incorporates a startup system (relocation detection system), which disables operation when an unexpected vibration is applied or the machine is relocated. Be sure to contact your nearest Mitutoyo prior to relocating this machine after initial installation.

Dimensions

● Main unit

Unit: mm

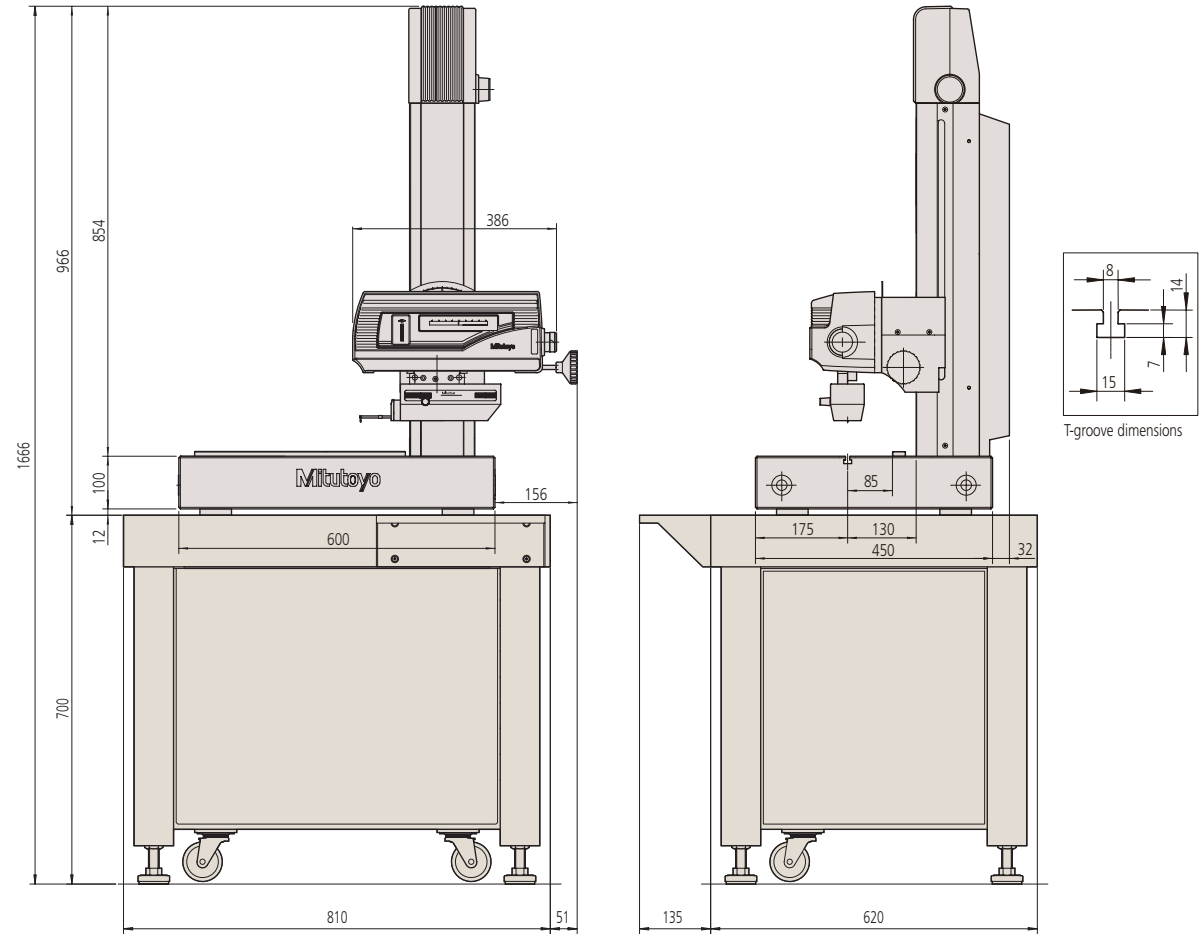

◆ Measurement range

Normal detector position

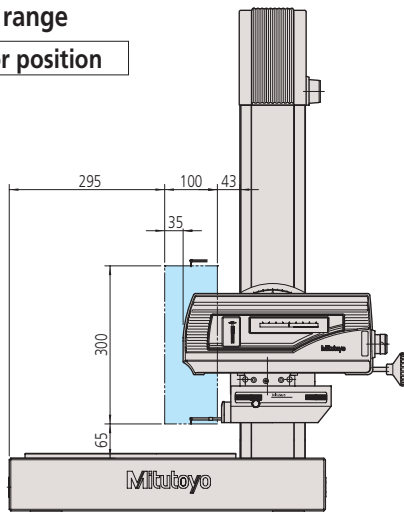

When detector is maximally extended
(Extended by 2.76" (70mm) from normal position)

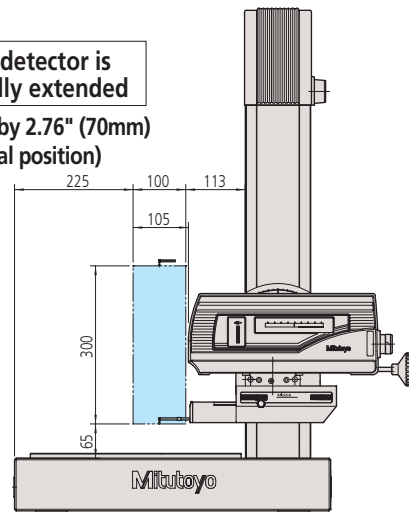

* The detector unit can be clamped at any position between normal and the maximum extended position.

CNC Models for Ultimate Accuracy & Efficiency

FORMTRACER EXTREME CS-H5000CNC

X1-axis

Range: 7.87" (200mm)
 Resolution: 0.00625 μ m
 Accuracy*: $\pm(0.16+0.001L)$ μ m
 * At 20°C, L = Measured length inch (mm)

Z1-axis

Range: .47" (12mm)
 Resolution: 0.001 μ m
 Accuracy*: $\pm(0.07+|0.02H|)$ μ m
 * At 20°C, H = Measured height inch (mm)



Note: All information regarding our products, and in particular the illustrations, drawings, dimensional and performance data contained in this printed matter as well as other technical data are to be regarded as approximate average values. We therefore reserve the right to make changes to the corresponding designs. The stated standards, similar technical regulations, descriptions and illustrations of the products were valid at the time of printing. In addition, the latest applicable version of our General Trading Conditions will apply. Only quotations submitted by ourselves may be regarded as definitive.

Mitutoyo products are subject to US Export Administration Regulations (EAR). Re-export or relocation of Mitutoyo products may require prior approval by an appropriate governing authority.

Trademarks and Registrations

Designations used by companies to distinguish their products are often claimed as trademarks. In all instances where Mitutoyo America Corporation is aware of a claim, the product names appear in initial capital or all capital letters. The appropriate companies should be contacted for more complete trademark and registration information.

We reserve the right to change specifications and prices without notice.

Coordinate Measuring Machines	=====
Vision Measuring Systems	=====
Form Measurement	=====
Optical Measuring	=====
Sensor Systems	=====
Testing Equipment and Seismometer	=====
Digital Scale and DRO Systems	=====
Small Tool Instruments and Data Management	=====

Mitutoyo America Corporation

www.mitutoyo.com

One Number to Serve You Better
1-888-MITUTOYO (1-888-648-8869)

M³ Solution Centers

Aurora, Illinois
 (Corporate Headquarters)

Westford, Massachusetts

Huntersville, North Carolina

Mason, Ohio

Plymouth, Michigan

City of Industry, California

Mitutoyo

Precision is our Profession