

CRYSTA-PLUS M

Bulletin No. 2107

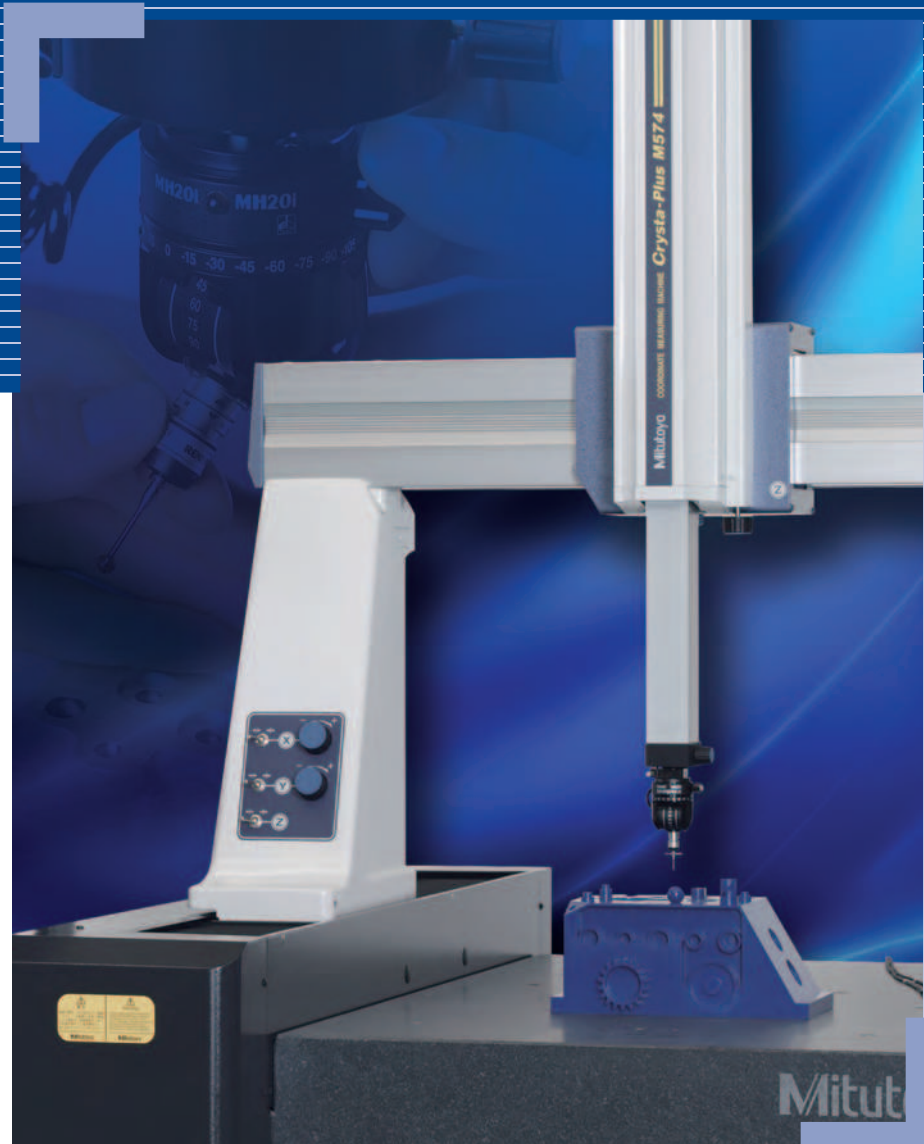

A low cost, highly accurate, compact and easy-to-operate measuring instrument featuring frictionless air-bearing suspension

Mitutoyo

CRYSTA-PLUS M: Precision that couldn't be clearer

Welcome to the world of 3D coordinate measuring technology!

CRYSTA-PLUS M is the intelligent alternative to complex and cost-intensive measuring machines or conventional measuring tools. As a high-performance manual 3D coordinate measuring instrument, CRYSTA-PLUS M comes into its own wherever constantly changing measuring tasks, many different types of workpiece and random sampling is the order of the day.



Manual

CRYSTA-PLUS M

All-in-all the most economical solution

Measuring work is a highly individual matter - particularly where measurements cannot always be made in seconds. Spot-checking in production or special tasks, for instance, or pre-setting tools in diesinking EDM. Here, and in all other special measurement tasks, CRYSTA-PLUS M is the ideal solution for performance- and cost-conscious users. CRYSTA-PLUS M combines the capabilities of many individual measuring and test instruments in a single, economical, all-round system - making enormous savings possible from purchase and use all the way through to long-term maintenance.

Economical

CRYSTA-PLUS M comes with high-end MCOSMOS software with Mitutoyo Intelligent Computer Aided Technology (MiCAT) as standard, the user-friendly command center for professional measuring and evaluation. Combined with numerous optional application-specific modules, MCOSMOS will rise with ease to any challenge, however demanding the specification.

Add to that a highly versatile, use-specific range of accessories from specially designed sensor systems through to a flexible clamping system.

With CRYSTA-PLUS M, a whole world of high-performance manual 3D coordinate measuring will open up to you. The plus in performance will soon pay for itself.



Higher quality, point for point

- Length measuring accuracy 3.5 µm*: impressively accurate for manual 3D coordinate measurement
- High-precision (resolution: 0.5 µm), dustproof glass scales on all axes
- Mitutoyo PC based MCOSMOS software as standard
- Voice guidance for operator through use of MCOSMOS software
- Self-adjusting air bearings on all axes
- FEM-aided design ensures geometric accuracy and vibration resistance
- 3 sizes to choose from
- Space saving and light, compact design built with high quality materials
- Outstanding price/performance ratio
- Integrated thermal-effect and volumetric-error compensation for instrument and workpiece in the temperature range 16 °C to 26 °C (can be added as an option)



Versatile

NOTE: PC system & workstation provided are not as shown



* For models with 500 mm X-axis travel:
MPEE = (3.5+0.45L/1000) µm with TP20/MH20I probes in the temperature range 19 °C to 21 °C (or 16 °C to 26 °C using the optional thermal-effect compensation).

CRYSTA-PLUS M: Simply the best ideas

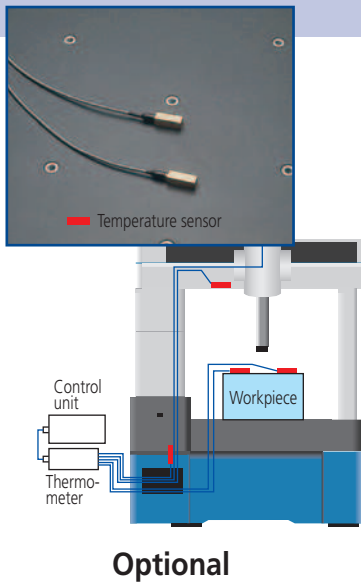

Optional

The measuring results are stable even when temperatures fluctuate (option)

Even with the machine environment and the workpiece temperature fluctuating between 16 °C and 26 °C, CRYSTA-PLUS M measures as if thermal conditions were stable. Sensors on the CRYSTA-PLUS M and workpiece record temperature variations and feed the information to the automatic thermal-effect compensation system, which then corrects all measurements back to 20 °C in real time. This results in shop floor measurements being made to a level of accuracy only otherwise possible in thermally stable measurement laboratories.

Corrections made clear

Temperature-dependent correction using an 800 mm steel gauge block as an example - measured with alternating environmental temperatures diagonally in the room.

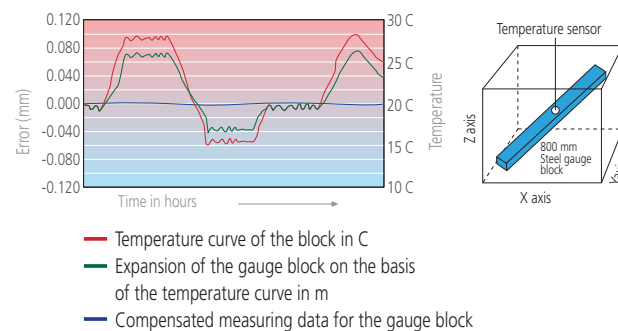

Intelligent

Precise

Positive positioning

All models include air locks for each axis in conjunction with fine adjustment for the X and Y axes. The 7106 model includes rapid traverse in the X, Y, Z axes and the air locks are integrated into a remote switch box.



Uncomplicated

Voice guidance

CRYSTA-PLUS M provides voice guidance for the user throughout the MCOSMOS Software. This prevents misunderstandings and directs full concentration on guiding the instrument. This enables even less-experienced operators to carry out complex measuring tasks safely and without error.

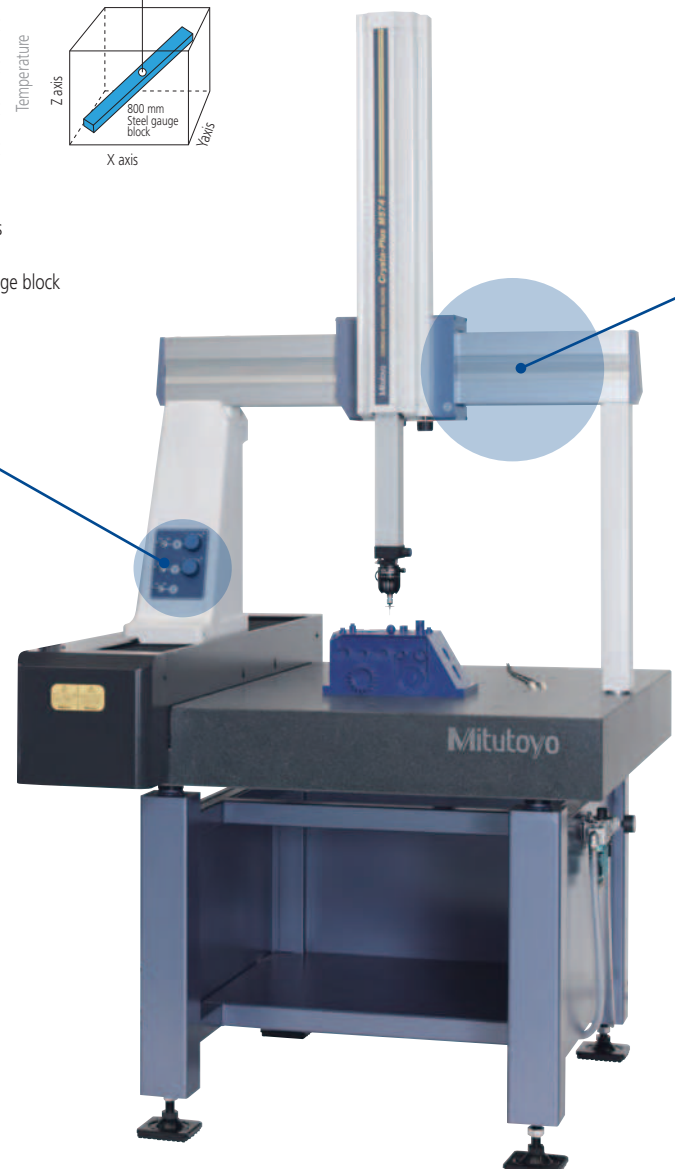

Uncomplicated

Air bearings on all axes

Self-adjusting air bearings on all axes allow CRYSTA-PLUS M to move the probe with outstanding smoothness, speed and precision. They form the basis for absolute measuring accuracy.

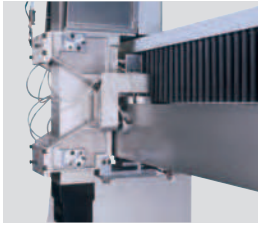

Superior

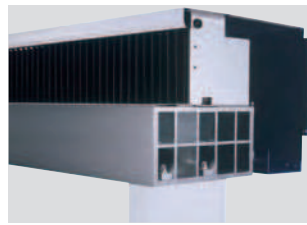

Compact

Space-saving and light

CRYSTA-PLUS M does not require any special constructual prerequisites at the installation site. Thanks to particularly high-quality lightweight materials and space-saving dimensions, a hard and stable mounting surface with normal machine-standard foundations is quite sufficient.

Modern technology for accurate guidance

Finite element method (FEM) analysis was used to achieve a highly rigid bridge structure design that ensures exceptional guideway straightness and good suppression of vibrations. The high thermal conductivity of the aluminium guideways helps prevent deflection and twisting due to thermal-gradient effects.

Stable

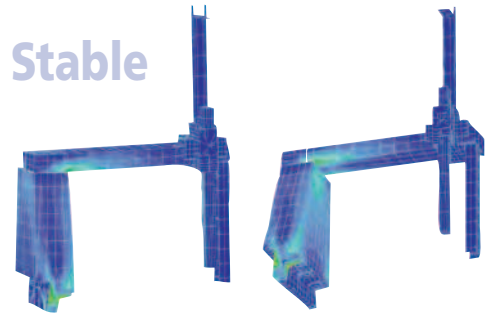

Dustproof glass scales

CRYSTA-PLUS M uses high-precision dustproof glass scales with a resolution of 0.5 μm . Optional sensors on the instrument scales provide temperature compensation. This makes CRYSTA-PLUS M particularly suitable for use in a harsh production environment.



Scale with optional temperature sensor

Constant

Constant measurement

The ergonomically designed guide grip on the Z axis helps prevent measurement inaccuracies due to any unsteadiness in manual operation.

NOTE: Only available on 7106 model



Quality with complete versatility

Series M400



Series M500



Series M700



Model		Crysta-Plus M443	Crysta-Plus M574	Crysta-Plus M7106
Measuring Range	X axis	15.74" (400mm)	19.68" (500mm)	27.55" (700mm)
	Y axis	15.74" (400mm)	27.55" (700mm)	39.36" (1000mm)
	Z axis	11.81" (300mm)	15.74" (400mm)	23.62" (600mm)
Workpiece	Max. workpiece height	18.89" (480mm)	23.22" (590mm)	31.49" (800mm)
	Max. table loading	396lbs (180kg)	396lbs (180kg)	1763lbs (800kg)
Workpiece Clamping	No. of M8 x 1.25" Threaded Holes	13	13	13
Machine Accuracy	ISO 10360-2 (20 °C ±1 °C)	E=(3.0+4.0L/1000)µm	E=(3.5+4.0L/1000)µm	E=(4.5+4.5L/1000)µm
Probe Repeatability	ISO 10360-2	R=4.0µm (TP20)	R=4.0µm (TP20)	R=5.0µm (TP20)
Environmental temperature		20 °C ±1 °C	20 °C ±1 °C	20 °C ±1 °C
Resolution	Length measuring system	.00002" (0.5µm)	.00002" (0.5µm)	.00002" (0.5µm)
Guidance		Air bearings on all axes	Air bearings on all axes	Air bearings on all axes
Measuring Table	Material	Granite	Granite	Granite
	Dimensions	24.56" x 51.97" (624 x 805mm)	30.07" x 46.25" (764 x 1175mm)	35.43" x 68.50" (900 x 1740mm)
Air supply	Consumption/air pressure	1.76 CFM @ 51 PSI (ca. 50 l/min @ 0.35 MPa)	1.76 CFM @ 51 PSI (ca. 50 l/min @ 0.35 MPa)	1.76 CFM @ 58 PSI (ca. 50 l/min @ 0.4 MPa)
Dimensions	Width	38.62" (981mm)	44.17" (1122mm)	57.48" (1460mm)
	Depth	41.22" (1047mm)	56.45" (1434mm)	76.77" (1950mm)
	Height	77.44" (1967mm)	89.25" (2267mm)	111.81" (2840mm)
Mass	(with supporting table)	904lbs (410kg)	1424lbs (646kg)	3968lbs (1800kg)

CRYSTA-PLUS M

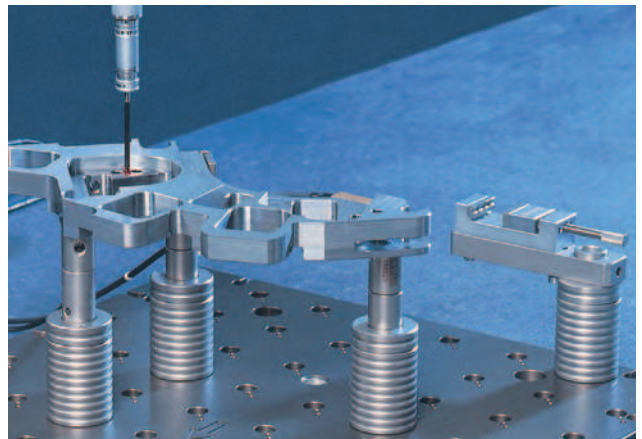
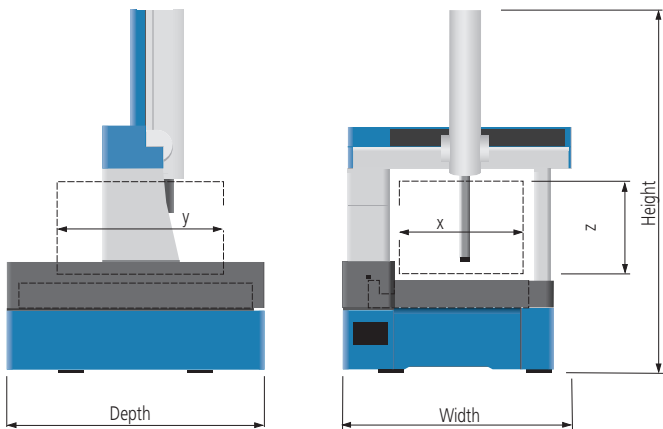

Quality and versatility in every case: Mitutoyo measuring systems

Leaving nothing to chance in your measuring tasks, Mitutoyo offers an extremely wide range of contact and non-contact measuring systems. Each part is carefully coordinated with the multisensor capability of the CRYSTA-PLUS M.

Contact measuring systems				Non-contact measuring systems
Manual, stepless, rotating measuring systems		Manual rotating, indexable measuring systems		Centering microscope
Measuring head with separate measuring probe	Measuring head with separate measuring probe	Measuring head with separate measuring probe (indexable)	Measuring head with separate measuring probe (indexable)	Located via spindle

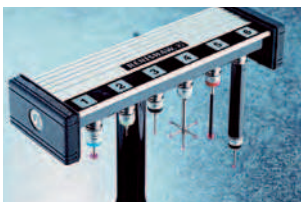
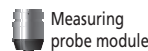
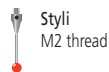
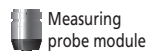
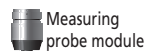
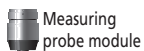

Probe module holder
Manual rack MSR1

Versatile



mcosmos

Applications that support your measurement tasks



MCOSMOS Manual (GEOPAK) High Performance General-Purpose Measurement Program

This module is the heart of the MCOSMOS software system and is used to measure and analyze geometric elements. All the functions are provided by icons or pull-down menus for quick and seamless operation. It is unnecessary to switch windows for operations, so even novices can promptly select desired functions. Its main features include easier viewing of measuring procedures and results such as realtime graphic display of measurement results and a function for direct callup of elements from results graphics.

Resin molded or plastic formed products



SCANPAK Optional Contour Measurement Program

Measures two-dimensional unfiltered profiles and performs various evaluations. It can evaluate profile measurement data, based on design data, and calculate various elements and inter-elements by specifying a range from the measurement data.

CAT1000S Optional Free Curved Surface Evaluation Program

Checks and compares the workpiece with the CAD data and directly outputs the results in the form of CAD data in various formats. It supports IGES/VDAFS CAD data as standard, and software to directly convert from/to various types of CAD data is available as an option.

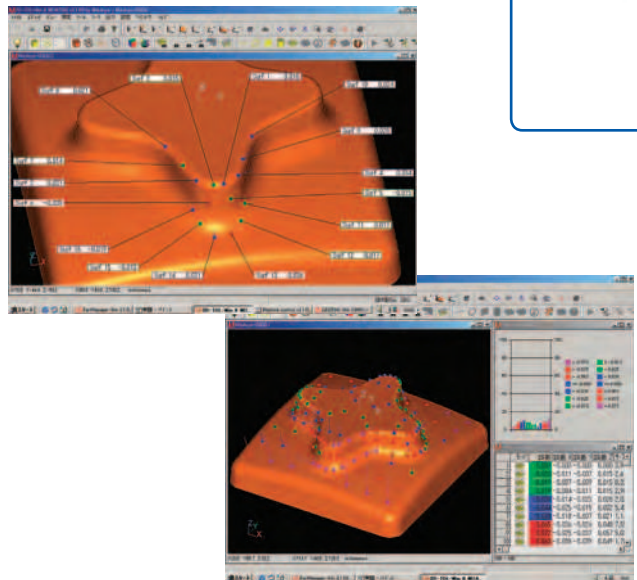
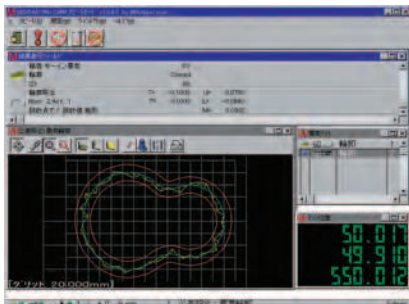
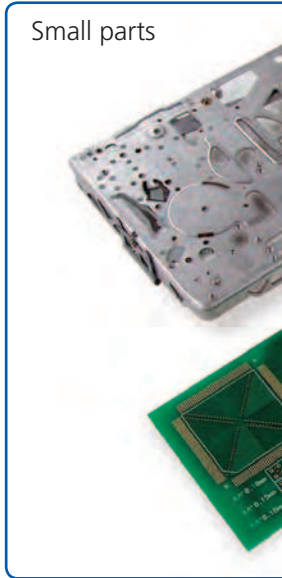

Touch Trigger Probe



This is a sensor that collects the coordinate values of the surface of a workpiece which the stylus contacts. Various interchangeable styli are available to suit the task in hand: such as ball styli with various diameters, and others with specially shaped tips to best meet the requirements of a large variety of workpiece shapes and evaluation methods.

Centering Microscope

This microscope can measure delicate, easily deformed objects which are difficult to measure by contact-type methods. Observation and measurement are possible through an optional TV monitor. (Requires footswitch - OPTIONAL)

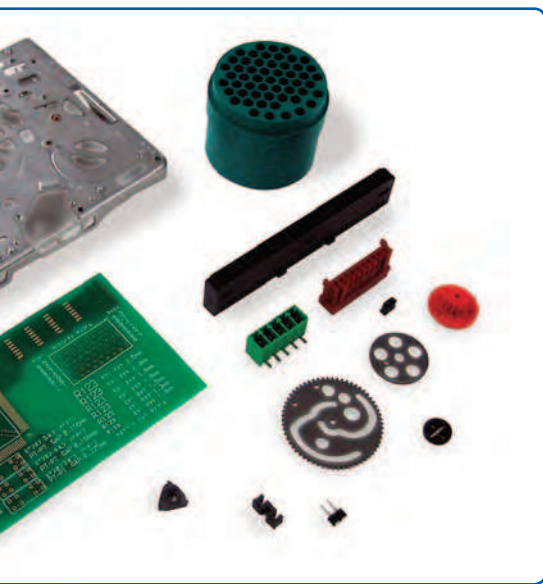

MeasurLink®

Optional Statistical Processing, Process Control Program

This program can process various statistical analyses based on the measurement results. A real time display of a control chart allows earlier detection of potential defects such as wear or damage to cutting tools. This allows implementation of effective countermeasures including changes in cutting depth and working conditions. Using this program as a terminal, it is also possible to connect to a higher network environment for integrated control.

Cutting finished products

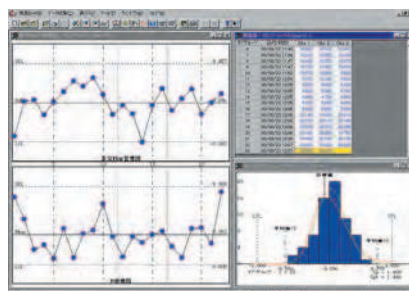



NOTE: PC system & workstation provided are not as shown

With Mitutoyo's coordinate measuring machines, you can be sure of gaining the competitive edge provided by the experience and expertise of the world's leading specialist in production measurement technology. You are also benefiting from knowledge accumulated over decades for the tasks of tomorrow. Setting the highest standards in quality, and performance.

Note: All information regarding our products, and in particular the illustrations, drawings, dimensional and performance data contained in this printed matter as well as other technical data are to be regarded as approximate average values. We therefore reserve the right to make changes to the corresponding designs. The stated standards, similar technical regulations, descriptions and illustrations of the products were valid at the time of printing. In addition, the latest applicable version of our General Trading Conditions will apply. Only quotations submitted by ourselves may be regarded as definitive.

Mitutoyo products are subject to US Export Administration Regulations (EAR). Re-export or relocation of our products may require prior approval by an appropriate governing authority.

Trademarks and Registrations

Designations used by companies to distinguish their products are often claimed as trademarks. In all instances where Mitutoyo America Corporation is aware of a claim, the product names appear in initial capital or all capital letters. The appropriate companies should be contacted for more complete trademark and registration information.

- Coordinate Measuring Machines
- Vision Measuring Systems
- Form Measurement
- Optical Measuring
- Sensor Systems
- Test Equipment and Seismometers
- Digital Scale and DRO Systems
- Small Tool Instruments and Data Management

Mitutoyo America Corporation

www.mitutoyo.com

One Number to Serve You Better
1-888-MITUTOYO (1-888-648-8869)

M³ Solution Centers

Aurora, Illinois
 (Corporate Headquarters)

Westford, Massachusetts

Huntersville, North Carolina

Mason, Ohio

Plymouth, Michigan

City of Industry, California

Birmingham, Alabama



Precision is our Profession