

# Benchtop/Rack-mount Programmable Switches

## SB/SC Series



SB Series



SC Series

### Key Features

- SB series can accommodate up to 20 channels and offer up to two input channels
- SC series can accommodate up to 178 channels and offer up to four input channels
- Low IL, 0.4 dB typical
- Excellent repeatability,  $\pm 0.003$  dB typical
- High return loss (RL) > 65 dB typical
- GPIB and RS232 remote control

### Applications

- Fiber optic component testing and measurement
- System testing
- Research and development (R&D)
- Network monitoring

### Safety Information

- Complies with CE requirements plus UL3101-1 and CAN/CSA-C22.2 No.1010.1

The JDSU SB and SC Series of Benchtop/Rack-mount Programmable Switches can be controlled using the front panel keys and a numeric pad or via GPIB and serial RS232 interface.

The SB and SC series switches are available in three basic configurations, which are illustrated in Figures 1, 2, and 3, respectively.

- **C configuration:** is a single common input model (SB, SC)
- **D configuration:** provides simultaneous connection of a bank of input fibers to output fibers (SB, SC)
- **E configuration:** allows for connecting any input to any output while other inputs/outputs are aligned to subsequent/adjacent channels. The switch is non-blocking in this mode and other inputs/outputs are aligned (SB, SC).

Operation of these switches is based upon the JDSU-proven expanded beam lens technology, which utilizes a precision stepper-motor to align optical channels. The use of collimating lenses minimizes insertion loss (IL) and improves repeatability and performance. Internal temperature control of the switching mechanism ensures excellent operational stability.

Both single-mode (SM) and multimode (MM) versions of the SB and SC series switches are available. The series features the high level of performance required for multi-unit testing in R&D and in manufacturing environments. The compact, portable SB switch and the standard rack-mount enclosure SC switches are highly suited for applications in telecommunications, manufacturing, and test environments.

The JDSU SB and SC switches are known in the fiber optics industry for their low IL and excellent repeatability. In addition to the many *Quick Picks* options available, JDSU can also provide *Specialized* switches in this series to meet your specific application needs.

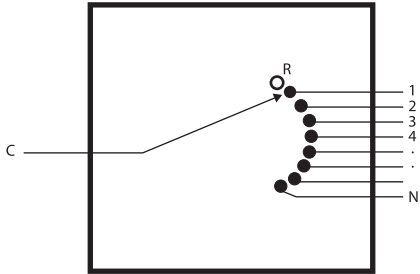

Figure 1. 1x N Switching: C Configuration (SB and SC)  
The 1xN configuration allows a single common input to be switched to any of the outputs.

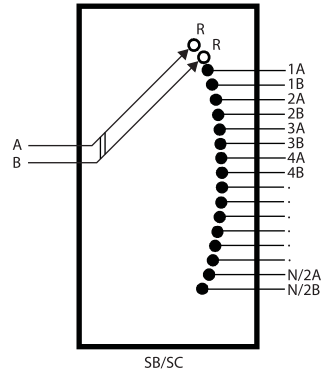

Figure 2. Ganged Switching: D Configuration (SB/SC)  
The MxN configuration provides simultaneous connections of a bank of inputs to outputs.

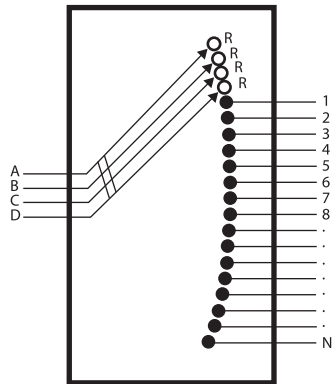

Figure 3. Sequential Switching: E Configuration (SB/SC)  
The MxN configuration aligns any input with any output, while other inputs are aligned to adjacent outputs.

3

SB Model Specifications

Parameter <sup>1</sup>	Single Common C Configuration		Multiple Common D Configuration		Multiple Common E Configurations	
	Typical	Maximum	Typical	Maximum	Typical	Maximum
Insertion loss (IL)						
Single-mode (SM)	0.4 dB	0.7 dB	0.4 dB	0.7 dB	0.5 dB	1.0 dB
Multimode (MM)	0.4 dB	0.7 dB	0.4 dB	0.7 dB	0.5 dB	1.0 dB
Return loss (RL) <sup>2</sup>						
SM standard/analog	>65 dB	60/65 dB	>65 dB	60/65 dB	65 dB	60 dB
MM <sup>3</sup> standard/analog	25/35 dB	20/30 dB	25/35 dB	20/30 dB	>25 dB	20 dB
Polarization dependent loss (PDL) SM	0.02 dB	0.05 dB	0.02 dB	0.05 dB	0.03 dB	0.07 dB
IL stability <sup>4</sup>	±0.03 dB	±0.05 dB	±0.03 dB	±0.05 dB	±0.03 dB	±0.05 dB
Repeatability <sup>5</sup>						
Sequential switching	±0.003 dB	±0.005 dB	±0.005 dB	±0.01 dB	±0.005 dB	±0.01 dB
Random switching	±0.01 dB	±0.025 dB	±0.02 dB	±0.04 dB	±0.02 dB	±0.04 dB
Crosstalk (maximum) SM			-80 dB			
Maximum input power (optical)			300 mW			
Lifetime			>80 million cycles			
Switching time						
One channel			300 ms			
Each additional channel			12 ms			
Power supply			100 to 240 V, 50 to 60 Hz			
Power consumption			100 V A maximum			
Control			Local and remote via GPIB and serial RS232 interfaces			
Drivers for external switch modules			Four open collector drivers with maximum 100 mA sink current			
Operation temperature			0 to 55°C			
Storage temperature			-40 to 70°C			
Humidity			maximum 95% RH from 0 to 55°C non-condensing			
Dimensions (W x H x D)			21.2 x 8.9 x 35.5 cm			
with rack-mount kit (optional) <sup>6</sup>			48.3 x 8.9 x 35.5 cm			
Weight			3.75 kg			

1. Excluding connectors. All optical measurements taken after temperature has been stabilized for one hour, at ambient (room) conditions.
2. RL specification based on 1 m pigtail length.
3. Values shown for 62.5 μm diameter maximum fiber core.
4. Drift of any channel relative to reference channel at ±3°C deviation of ambient temperature over a 7-day period.
5. Measured between two consecutive readings over 100 cycles.
6. ED000899-A-00 standard rack-mount kit. Requires two kits to mount two units side-by-side. Please specify part number when ordering (if needed).

4

SC Model Specifications

Parameter <sup>1</sup>	Single Common C Configuration (SC Model only)		Multiple Common D Configuration		Multiple Common E Configurations	
	Typical	Maximum	Typical	Maximum	Typical	Maximum
IL						
SM	0.4 dB	0.7 dB	0.4 dB	0.7 dB	0.5 dB	1.0 dB
SC with 4 inputs	—	—	0.5 dB	1.0 dB	0.7 dB	1.5 dB
MM	0.4 dB	0.7 dB	0.4 dB	0.7 dB	0.5 dB	1.0 dB
SC with 4 inputs	—	—	0.5 dB	1.0 dB	0.7 dB	1.5 dB
RL <sup>2</sup>						
SM standard/analog	>65 dB	60/65 dB	>65 dB	60/65 dB <sup>3</sup>	>65 dB	60 dB
MM <sup>4</sup> standard/analog	25/35 dB	20/30 dB	25/35 dB <sup>3</sup>	20/30 dB <sup>3</sup>	>25 dB	20 dB
PDL SM	0.02 dB	0.05 dB	0.02 dB	0.05 dB	0.03 dB	0.07 dB
IL stability <sup>5</sup>	±0.03 dB	±0.05 dB	±0.03 dB	±0.05 dB	±0.03 dB	±0.05 dB
Repeatability <sup>6</sup>						
Sequential switching	±0.003 dB	±0.005 dB	±0.005 dB	±0.01 dB	±0.005 dB	±0.01 dB
Random switching	±0.01 dB	±0.025 dB	±0.02 dB	±0.04 dB	±0.02 dB	±0.04 dB
Crosstalk (maximum) SM			-80 dB			
Maximum input power (optical)			300 mW			
Lifetime			>80 million cycles			
Switching time						
One channel			300 ms (420 ms)			
Each additional channel			12 ms (20 ms)			
Power supply			100 to 240 V, 50 to 60 Hz			
Power consumption			100 V A maximum			
Control			Local and remote via GPIB and serial RS232 interfaces			
Drivers for external switch modules			Four open collector drivers with maximum 100 mA sink current			
Operation temperature			0 to 55°C			
Storage temperature			-40 to 70°C			
Humidity			Maximum 95% RH from 0 to 55°C non-condensing			
Dimensions (W x H x D) single (double height) <sup>6</sup>			48 x 13 x 37 cm (48 x 26.6 x 37 cm) excluding handles			
Weight single (double height) <sup>7</sup>			9 kg (14 kg)			

1. Excluding connectors. All optical measurements taken after temperature has been stabilized for one hour, at ambient (room) conditions.
2. RL specification based on 1 m pigtail length.
3. Analog version available on one and two input SC model switches (C and D configurations).
4. Values shown for 62.5 μm diameter maximum fiber core.
5. Drift of any channel relative to reference channel at ±3°C deviation of ambient temperature over a 7-day period.
6. Measured between two consecutive readings over 100 cycles.
7. Applies to SC model only.

## 5

## Ordering Information

## Quick Picks\*

The following selection of switches are popular configurations used for majority of switching applications:

<b>Product Code</b>	<b>Description</b>
<b>Single-Mode 1XN</b>	
SB1C10081+27XF000FP	1x8 C Configuration, Single-Mode, Standard RL Bulkhead FC/PC
SB1C10081+27XF000FA	1x8 C Configuration, Single-Mode, Standard RL Bulkhead FC/APC
SB1C10161+27XF000FP	1x16 C Configuration, Single-Mode, Standard RL Bulkhead FC/PC
SB1C10161+27XF000FA	1x16 C Configuration, Single-Mode, Standard RL Bulkhead FC/APC
SC1C10241+27XF000FP	1x24 C Configuration, Single-Mode, Standard RL Bulkhead FC/PC
SC1C10241+27XF000FA	1x24 C Configuration, Single-Mode, Standard RL Bulkhead FC/APC
SC1C10321+27XF000FP	1x32 C Configuration, Single-Mode, Standard RL Bulkhead FC/PC
SC1C10321+27XF000FA	1x32 C Configuration, Single-Mode, Standard RL Bulkhead FC/APC
SC1C10401+27XF000FP	1x40 C Configuration, Single-Mode, Standard RL Bulkhead FC/PC
SC1C10401+27XF000FA	1x40 C Configuration, Single-Mode, Standard RL Bulkhead FC/APC
<b>Single-Mode 2XN</b>	
SB2E10161+27XF000FP	2x16 E Configuration, Single-Mode, Standard RL Bulkhead FC/PC
SB2E10161+27XF000FA	2x16 E Configuration, Single-Mode, Standard RL Bulkhead FC/APC
SC2E10241+27XF000FP	2x24 E Configuration, Single-Mode, Standard RL Bulkhead FC/PC
SC2E10241+27XF000FA	2x24 E Configuration, Single-Mode, Standard RL Bulkhead FC/APC
SC2E10401+27XF000FP	2x40 E Configuration, Single-Mode, Standard RL Bulkhead FC/PC
SC2E10401+27XF000FA	2x40 E Configuration, Single-Mode, Standard RL Bulkhead FC/APC
<b>Multimode 1XN</b>	
SB1C10041+22XQ000FP	1x4 C Configuration, 62.5/125 $\mu\text{m}$ , Standard RL Bulkhead FC/PC
SB1C10081+22XQ000FP	1x8 C Configuration, 62.5/125 $\mu\text{m}$ , Standard RL Bulkhead FC/PC
SB1C10121+22XQ000FP	1x12 C Configuration, 62.5/125 $\mu\text{m}$ , Standard RL Bulkhead FC/PC
SC1C10241+22XQ000FP	1x24 C Configuration, 62.5/125 $\mu\text{m}$ , Standard RL Bulkhead FC/PC
SB1C10041+21XQ000FP	1x4 C Configuration, 50/125 $\mu\text{m}$ , Standard RL Bulkhead FC/PC
SB1C10081+21XQ000FP	1x8 C Configuration, 50/125 $\mu\text{m}$ , Standard RL Bulkhead FC/PC
SB1C10121+21XQ000FP	1x12 C Configuration, 50/125 $\mu\text{m}$ , Standard RL Bulkhead FC/PC
SC1C10241+21XQ000FP	1x24 C Configuration, 50/125 $\mu\text{m}$ , Standard RL Bulkhead FC/PC
<b>Multimode 2XN</b>	
SC2E10241+22XQ000FP	2x24 E Configuration, 62.5/125 $\mu\text{m}$ , Standard RL Bulkhead FC/PC
SC2E10241+21XQ000FP	2x24 E Configuration, 50/125 $\mu\text{m}$ , Standard RL Bulkhead FC/PC

\* Quick pick switches ship from stock with short lead times. All switches are shipped with north american style power cords.

If these configurations do not meet your performance requirements, please contact one of our regional sales team members to discuss potential specialized solutions.



7

Ordering Information

Specialized Offering\*

For 64 to 88 output channels in a 6U rack-mount SC packaging with option of bulkhead or pigtail connectors:

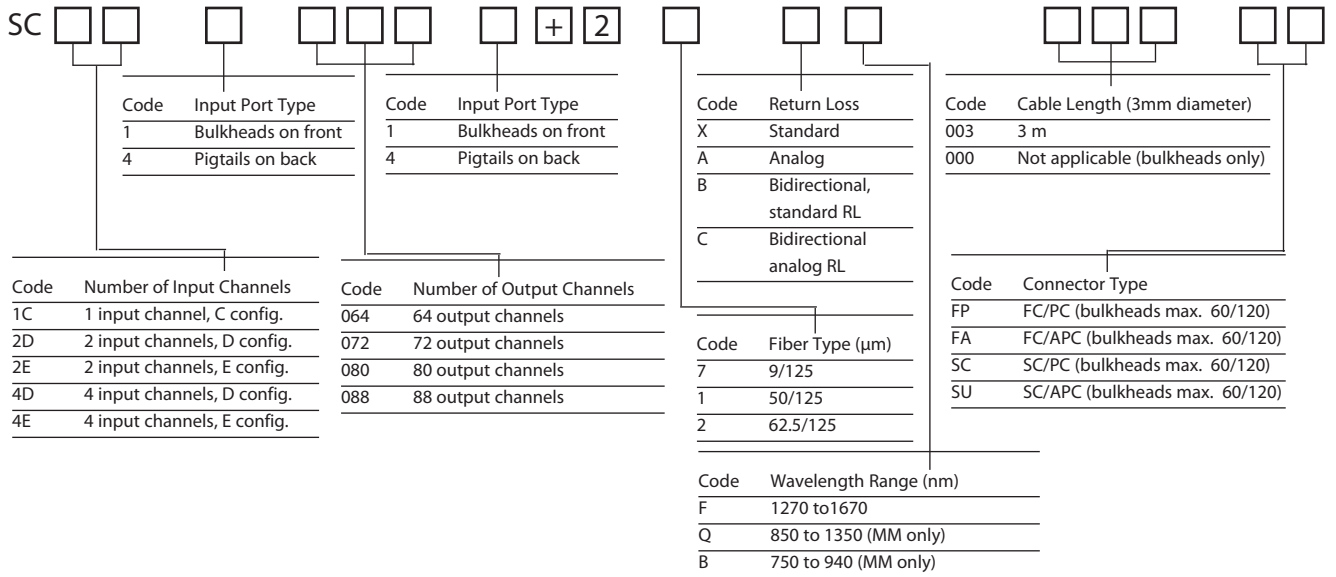

For 96 to 178 output channels in a 6U rack-mount SC packaging with pigtails:

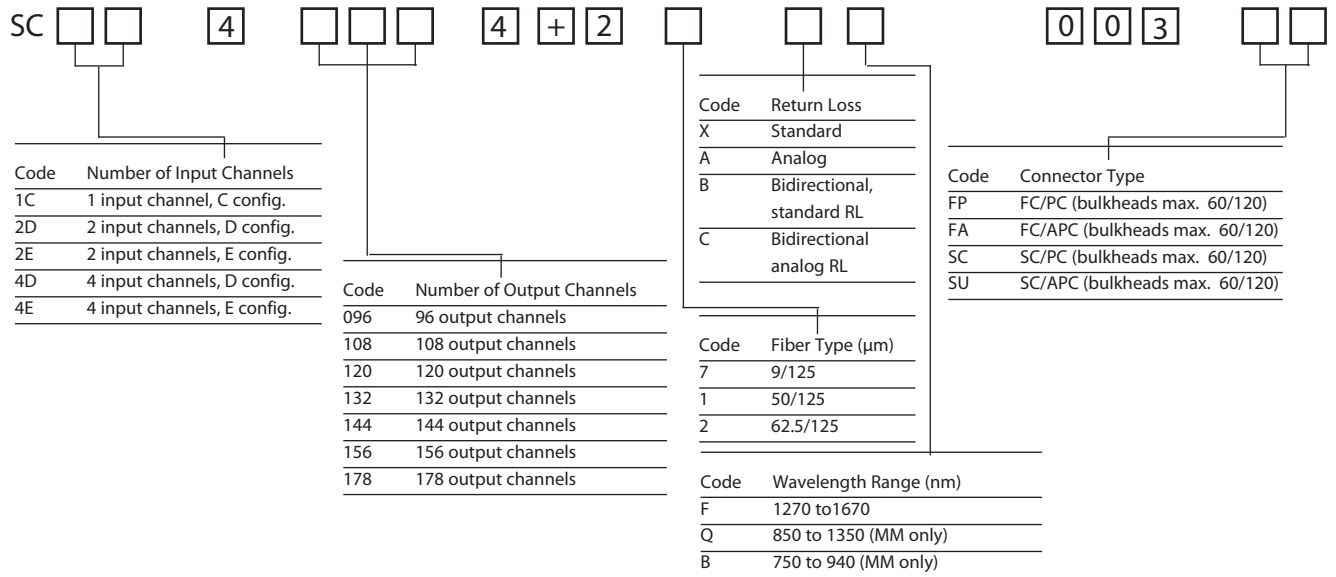

\* All switches are shipped with north american style power cords.

If these configurations do not meet your performance requirements, please contact one of our regional sales team members to discuss potential specialized solutions.

## Test &amp; Measurement Regional Sales

NORTH AMERICA TEL: 1 866 228 3762 FAX: +1 301 353 9216	LATIN AMERICA TEL: +1 954 688 5660 FAX: +1 954 345 4668	ASIA PACIFIC TEL: +852 2892 0990 FAX: +852 2892 0770	EMEA TEL: +49 7121 86 2222 FAX: +49 7121 86 1222	<a href="http://www.jdsu.com/test">www.jdsu.com/test</a>
--	---	--	--	--