

HST-3000

DDS 4-Wire Local Loop Option



Key Benefits

- CSU/DSU emulation mode for head-to-head, loopback, and end-to-end testing
- Test DDS rates from 2.4 to 64 kbps
- Thoroughly test T1 including BERT and loop codes and emulate NIU/CSU
- Test BER on primary and secondary channels
- Provides in-depth copper measurements including DVOM, graphical TDR, RFL, and load coil counter
- Modular hardware and software architecture allows for flexible, easy upgrades
- Field-portable solution for 4-wire DDS service testing

Quickly Qualify and Troubleshoot Local Loop Installation

DDS continues to provide a revenue stream for local loop services. However, installing DDS services at the customer's premises can be extremely time-consuming and expensive. Technicians need to deploy and troubleshoot 4-wire DDS services effectively and efficiently, the first time. Meet these challenges with an easy-to-use, versatile test solution that reduces failures and repeat rates and enhances efficiency and ensures consistent test practices.

The powerful and versatile HST-3000 handheld solution tests DDS 4-wire local loop (4WLL), as well as the copper plant, T1, and ISDN. Because it is handheld, rugged, and easy to use, the HST-3000 is ideal for field use. Its modular design provides a scalable, all-in-one solution to test the DDS local loop and thoroughly test the facilities over which it is provided.

Equipped with the 4-Wire DDS testing option, the HST-3000 can perform necessary out-of-service tests, including loopback, head-to-head, and end-to-end to verify service and to troubleshoot the loop.

Service providers, end users, and manufacturers can use the high-quality, proven HST-3000 to qualify and install local-loop services. Automated setups and advanced testing features give the control needed to initiate faster service turn-up and maintenance, better workforce productivity, lower costs, and increased profitability. Each HST-3000 is built to order and is quickly and easily upgraded with new modules and software as application and technology needs change.

A Powerful Field-Service Solution

Out-of-service testing is essential for deploying DDS circuits to verify the physical layer, detect faulty equipment, and to ensure proper provisioning. With the HST-3000, technicians can emulate the CSU/DSU and can plug in to the 4-wire DDS circuit at the NID or DDS termination unit. Once connected to the circuit, technicians can qualify the local-loop circuit using a variety of BER patterns.

The HST-3000 enables user-friendly configuration of BER test patterns to match central office equipment or test loopback or head-to-head BER for primary and/or secondary channels. Use a pair of HST-3000s to perform a complete end-to-end network test.

Loopback Testing

The JDSU HST-3000 can be used to terminate the circuit at the customer premises and to initiate or respond to loopback requests from the network card. The HST-3000 can initiate and respond to V.54, CSU, and DSU loopbacks. Once the loopback is established, BERT patterns can be transmitted and received over the primary channel or the low-speed secondary channel. The HST-3000 can also perform BER analysis on the local loop to a hard loop at the OCU data port (OCU-DP) card, letting technicians test both pairs from the customer premises.

Head-to-Head Testing

Head-to-head testing helps to isolate problems between the customer premises and the central office. A known test pattern can be simultaneously transmitted in each direction between the HST-3000 and network test equipment for easier sectionalization of network and equipment troubles.

End-to-End Testing

If problems remain after running head-to-head or loopback tests, errors may have been introduced by another provider's network. Testing through to the far end can determine if the problem is outside the immediate network. Placing a pair of JDSU HST-3000s at either end of the line and conducting end-to-end loopback and head-to-head network tests will isolate the problem.

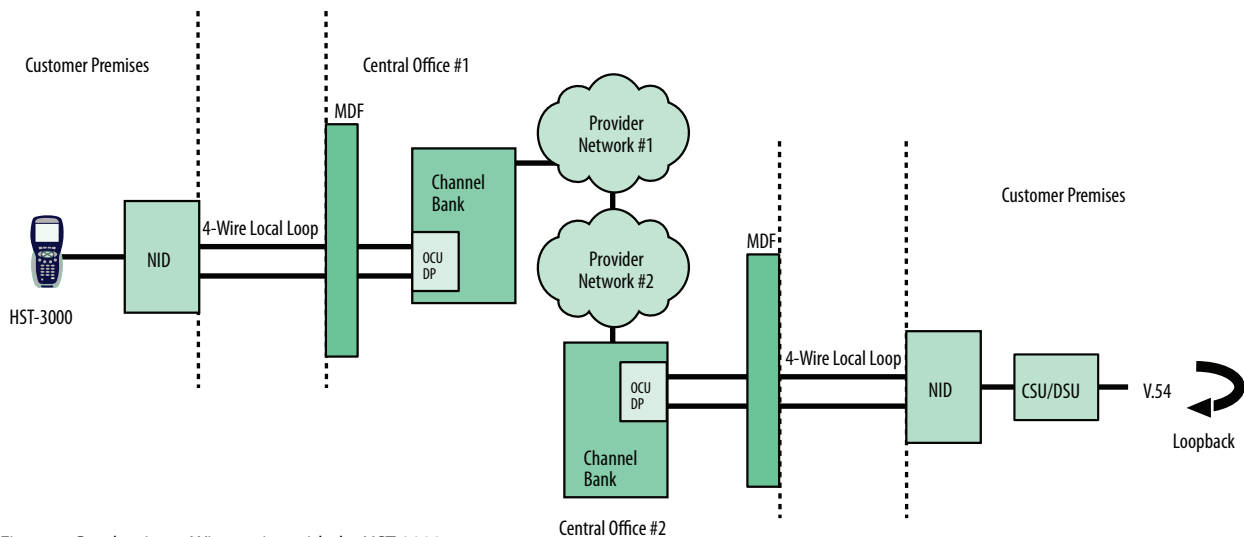

Figure 1. Conducting 4-Wire testing with the HST-3000

Test the Copper, Test the Service, Improve the Process

The HST-3000 equipped with the copper testing option can quickly troubleshoot the local loop for line impairments that degrade or impair DDS-LL performance. The HST-3000 helps technicians quickly identify and locate cable impairments, including shorts, grounds, opens, crosses, bridged taps, wet sections, and other highly resistive faults. These impairments are easy to access with the HST-3000's advanced time domain reflectometer (TDR), precision digital volt/ohm meter (DVOM), and an accurate resistive fault locator (RFL) to pinpoint issues prior to circuit installation.

The HST-3000 can transmit and receive wideband tones and can measure impulse and background noise to confirm that noise and loss meet acceptable criteria. Optimized copper test features for use anywhere on the local loop, such as at the NID, crossbox, pedestal, main distribution frame or anywhere technicians might gain access to the local loop, can locate the problem's source.

Qualify the 4-wire facility that carries the DDS service with BER analysis using a number of patterns, including all ones, 63, 511, 2047, and DDS-1 through DDS-6. The HST-3000 responds to CSU, DSU, and V.54 loopcodes, making it ideal as the responder for end-to-end or loopback BER testing.

The HST-3000's pre-programmed tests and customized scripts help all technicians, including novice users, follow the same procedures, eliminating mistakes from improper test configurations or incorrect procedures.

The HST-3000 with TechComplete™ software (optional customized) can improve turn-up and maintenance processes by operating with dispatch and closeout report systems to offload stored test results for later trend analysis and coaching reports. These HST-3000 features help to reduce repeat rates and failures for improved overall process efficiency.

Flexible and Rugged Design

The HST's rugged, weather-resistant design and long battery life are ideally suited for field use. Its modularity supports field upgrades to add new testing requirements. Standard Ethernet, USB, and serial connections offer flexibility to easily download software and offload captured test data.

Easily configurable, different technicians with varying responsibilities can use the HST-3000 to perform a wide range of tests. The HST-3000 can be easily upgraded with technologies and advanced options to meet the changing needs of service installers.

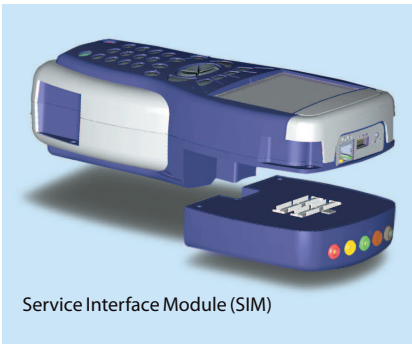

Service Interface Module (SIM)

Flexible, modular platform simplifies technology upgrades or hardware changes



HST-3000 Handheld Services Tester
Actual size: 9.5 x 4.5 x 2.75 in
Weight: 2.7 lb with battery

Specifications

Interfaces

DDS Local Loop 4-wire	RJ-48
10/100 BT Ethernet jack	8 pin modular
Serial port	DB9 female via cable (DCE)
USB Host	
USB Device	

DDS-LL

Operating Modes	Terminate CSU/DSU Emulation
Term Impedance	Rx 135 Ohms ±5%
DDS Data Rates	2.4, 4.8, 9.6, 19.2, 56, and 64 kb
Secondary Channel	IDLE, 511, 2047
Data Support	BERT

Clock Source Internal	Internal Recovered
Receive Signal Range	+6.0 to -43dB (56 to 64k rates) +6.0 to -34 dB (all other subrates)
Transmitter Output Levels	0, 3, 6, and 9 dB

Physical

Size (H x W x D)	241 x 114 x 70 mm (9.5 x 4.5 x 2.75 in)
Weight (with battery)	1.23 kg (2.7 lb)
Operating temperature	-5.5 to 50°C (22 to 122°F)
Storage temperature	-40 to 65.5°C (-40 to 150°F)
Battery life	10 hrs typical usage
Charging time	7 hrs from full discharge to full charge
Operating humidity	10 to 80% relative humidity
Storage humidity	10 to 95% relative humidity
Display	3.8-inch diagonal, 1/4 VGA, Color Active Matrix with backlight (readable in direct sunlight)

General

Ruggedness	Survives a 91 cm (3 ft) drop to concrete on all sides
Water-resistant	Splashproof (may be used in heavy rain)
Languages	English, German, French, Spanish, Italian, Chinese, Turkish
Keypad	Typical 12-button keyboard

Ordering Information

Base units

Part Number	Description
HST3000-NG	HST-3000 Mainframe without Copper (Color)
HST3000C-NG	HST-3000 Copper Mainframe (Color)

Available SIMS (Modules)

HST3000-4WLL	4-wire Local Loop
HST3000-AR2A	ADSL1/2/2+ (ATU-R, Annex A)
HST3000-AR2B	ADSL1/2/2+ (ATU-R, Annex B)
HST3000-BLK	Blank
HST3000-BRA	ETSI (Euro) ISDN BRA
HST3000-BRI	ISDN BRI
HST3000-CAR2A	ADSL1/2/2+ with Copper (ATU-R, Annex A)
HST3000-CAR2A-TI	Copper, ADSL2+ TI (ATU-R, Annex A)
HST3000-CAR2B-TI	Copper, ADSL2+ TI (ATU-R, Annex B)
HST3000-CSH4	Copper, 4-wire G.SHDSL (STU-R/C, Annex A/B)
HST3000-CT1	T1 and Copper
HST-3000-CU	Dual T/R/G Interface to Copper Test SIM
HST3000-CUCE	Copper only SIM, CE Marked
HST3000-DC	Datacom
HST3000-E1	E1
HST3000-E1-DC	E1/Datacom
HST3000-ETH	10/100/1000 Ethernet

HST3000-GSH	G.SHDSL
HST3000-T1	Dual Tx/Rx Bantam T1 Interface and T1
HST3000-T3	Dual Tx/Rx Bantam T1 Interface, and Dual Rx/ Single Tx BNC DS3 Interface/and DS3
HST3000-WB2	Wideband 2 (up to 30 MHz) Copper Test

Software Options

HST3000-802.11	802.11 Wireless
HST3000-BLUETOOTH	Bluetooth Wireless
HST3000-COS	Class of Service
HST3000-DSL2	ADSL2 and ADSL2+
HST3000-FR	Frame Relay
HST3000-FTP	FTP
HST3000-IPV6	IPv6
HST3000-MPLS	MPLS
HST3000-MSTR	Multiple Streams
HST3000-MSTV	Microsoft IPTV Video Analysis
HST3000-OPTETH	Optical Ethernet
HST3000-PCMSIG	Signaling (PCM)
HST3000-PCMTIMS	TIMS (PCM)
HST3000-PRI	ISDN PRI (NC Standard)
HST3000-PS	Pulse Shape
HST3000-REMOP	Remote Operation
HST3000-RFL	RFL

HST3000-SCRIPT	Scripted Test
HST3000-SPE	Spectral Noise
HST3000-ST	Basic Rate ISDN S/T (ANSI)
HST3000-T1DDS	DDS-T1
HST3000-TCPUDP	TCP/UDP
HST3000-TDR	TDR
HST3000-TxIMP	Transmission Impairments
HST3000-UNISTIM	VoIP Signaling Call Controls for UNISTIM
HST3000-VT100	VT100 Emulation
HST3000-WBTONES	WB TIMS
HST3000S-H.323	H.323 VoIP Signaling
HST3000S-IP	Advanced IP Suite— PING and Through Mode Support
HST3000S-IP-Video	IP Video Analysis
HST3000S-MGCP	SCCP MGCP VoIP Signaling
HST3000S-MOS	VoIP Mean Opinion Score
HST3000S-SCCP	SCCP VoIP Signaling
HST3000S-SIP	SIP VoIP Signaling
HST3000S-VMOS	Video MOS Analysis
HST3000S-VOIP	VoIP Software Analysis
HST3000S-WEB	Web Browser

Test & Measurement Regional Sales

NORTH AMERICA TEL: 1 855 ASK-JDSU 1 855 275-5378	LATIN AMERICA TEL: +1 954 688 5660 FAX: +1 954 345 4668	ASIA PACIFIC TEL: +852 2892 0990 FAX: +852 2892 0770	EMEA TEL: +49 7121 86 2222 FAX: +49 7121 86 1222	WEBSITE: www.jdsu.com/test
---	--	---	---	--