

# JD7105B/JD745A

## Base Station Analyzer



JD745A – Base Station Analyzer



JD7105B – Base Station Analyzer

Instrument	Spectrum Analyzer	Cable and Antenna Analyzer	Power Meter
JD7105B	100 kHz to 7.2 GHz	25 MHz to 4 GHz	10 MHz to 7.2 GHz
JD745A	100 kHz to 4 GHz	5 MHz to 4 GHz	10 MHz to 4 GHz

### Introduction

The Base Station Analyzers, JD7105B and JD745A, are the optimal test tool for installation and maintenance of cell sites. They contain all the features and capabilities required to perform field testing of cell sites of all wireless technologies, from 2G to 4G.

The Base Station Analyzers are equipped with one-button standard based measurements for wireless signals and offers the full scope of BTS conformance test. Its combined functionality includes spectrum analysis, cable and antenna analysis, power meter, interference analysis, channel scanner, E1/T1 analysis, and signal analysis.

The standard features of the Base Station Analyzers include the following:

- Spectrum Analyzer
- Cable and Antenna Analyzer
- Power Meter

The advance features of the Signal Analyzers are the following:

- Interference Analysis
- Channel Scanner
- E1 and/or T1 Analysis
- GPS Receiver
- Built-In Bias Tee
- Signal Analysis of cdmaOne/CDMA2000, EV-DO, GSM/ GPRS/ EDGE, WCDMA/HSDPA, TD-SCDMA, Mobile WiMAX, LTE-FDD, and LTE-TDD.

The Base Station Analyzers are the ideal field testing solution that combines portability, due to its lightweight design and battery extended operation, and performance, with its multifunction capability. In addition to its strong enclosure design for harsh environments and its backlight key panel makes nocturnal maintenance tasks possible.

## 2

### Features

#### Easy User Interface

The Base Station Analyzers have a consistent and intuitive interface through its multiple functions providing a common menu structure that is easy to use.

The Base Station Analyzers have a built-in help capability which guides users through each measurement task.

A screenshot of any functions can be saved as a graphic file for report generation and traces can be saved for post-analysis process into the instrument's internal memory or external USB memory device. The stored data can be easily transferred to a PC using its USB or Ethernet port. File name editing can be done with the instrument's rotary knob that also has the function of an enter button providing convenience to choose and select alphanumeric characters.



#### Field Useable Design

The Base Station Analyzers are compact and lightweight especially convenient for users performing field measurements. Its bright 8" color display provides visibility in daylight. And its backlight keys provide visibility on the dark.

The Base Station Analyzers have an operating temperature range from -10 to 55 Celsius; and its rugged bumper was designed to protect the instrument from drops or other external impacts exceeding the MIL-PRF-28800F class 2 specification.

#### Automatic Measurements

The Base Station Analyzers Auto Measure function allows a complete signal profiling covering RF characterization and modulation quality parameters of up to 10 different carriers, particularly useful on the base stations are transmitting in different frequencies.

Auto Measure can be easily executed and the instrument will automatically configure and test every aspect of all the carriers regardless of their frequency or modulation type. The Base Station Analyzers configurable channel scanner can track the power level of 20 carriers in a single measurement screen, tracking the power level of each carrier.

#### Multi language user interface

The instruments' architecture allows the graphical user interface to adapt into different languages, permitting localization around the world.

3

JD7105B Integrated Functionality

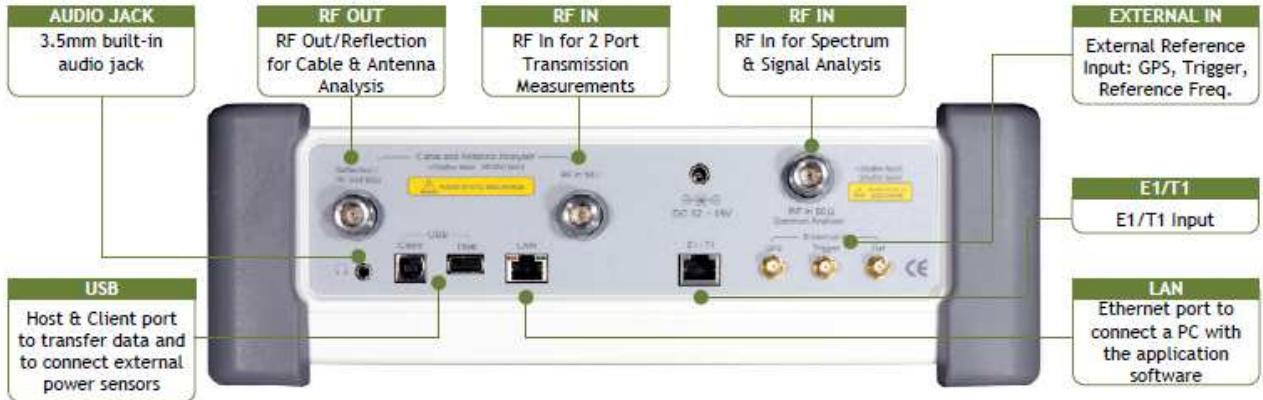

## 4

## JD7105B Integrated Functionality (cont'd)

**Spectrum Analyzer**  
**100 kHz to 7.2 GHz**

Locates and identifies various signals over a frequency range up to 7.2 GHz.

**Built in Pre-amplifier**

Detects signal as low as -160 dBm with phase noise -100 dBc/Hz at 30 kHz offset and measurement accuracy better than 1 dB.

**Zero Span with Gate Sweep**

Triggers pulse or burst signal such as WiMAX, GSM, and TD-SCDMA.

**Cable and Antenna Analyzer**  
**25 MHz to 4 GHz**

Provides cable and antenna characterization for proper power transfer from the radio to the antenna.

Locates failures points for an effective troubleshooting.

Verifies cable conformance specifications.

**Power Meter**

Integrated power meter eliminates the need of a separate instrument and provides power measurement with or without power sensors.

**2 Port Transmission Measurements**

Performance verification of passive and active devices such as filters and amplifiers.

**Bias Tee**  
**(option 013)**

Supplies up to 32 VDC built-in bias to active devices, such as amplifiers.

**CW Signal Generator**

Provides a sine wave or continuous wave (CW) source allowing measurements such as repeater's isolation.

**E1/T1 Analyzer**  
**(Option 002, 003)**

Comprehensive backhaul testing that isolates problems related to the incoming traffic from the fixed network.

**GPS Receiver and Antenna**  
**(Option 010)**

Provides geographical location and highly accurate frequency and time base enabling precise frequency measurements.

**Interference Analyzer**  
**(option 011)**

Provides the parameters of spectrogram and a multi-signal RSSI required to properly monitor, identify, and located interference signals. In addition it is capable of generating an audible variable tone accordingly to the signal strength.

**Channel Scanner**  
**(option 012)**

Intuitive graphical representation of the signal's power for each of the 20 user-definable carriers (frequencies or channels) allowing a fast identification of improper power levels.

**Signal Analyzer**  
**(option 020 to 029)**

Provides 3GPP/3GPP2/IEEE802.16 conformance for testing for power and spectrum, as well as modulation analysis from 2G to 4G wireless technologies.

**Over The Air Analyzer**  
**(option 040 to 049)**

Characterizes the transmission quality at any location providing reflective measurements and identifying signals providing from different sites.

5

JD745A Integrated Functionality

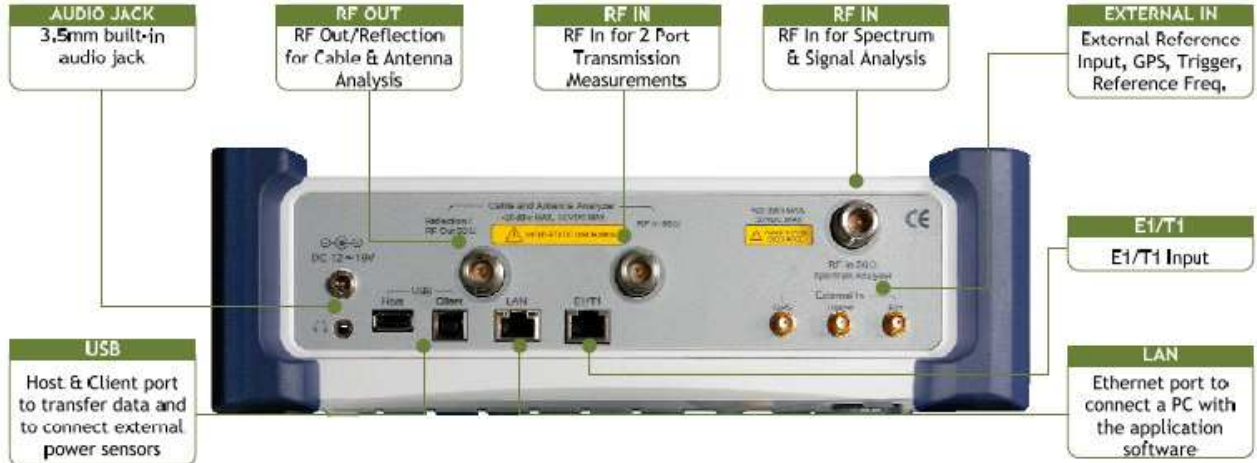

## 6

**JD745A Integrated Functionality (cont'd)****Spectrum Analyzer  
100 kHz to 4 GHz**

Locates and identifies various signals over a frequency range up to 4 GHz.

**Built in Pre-amplifier**

Detects signal as low as  $-155$  dBm with phase noise  $-90$  dBc/Hz at 30 kHz offset and measurement accuracy better than 1 dB.

**Zero Span with Gate Sweep**

Triggers pulse or burst signal such as WiMAX, GSM, and TDSCDMA.

**Cable and Antenna Analyzer  
5 MHz to 4 GHz**

Provides cable and antenna characterization for proper power transfer from the radio to the antenna.

Locates failures points for an effective troubleshooting.

Verifies cable conformance specifications.

**Power Meter**

Integrated power meter eliminates the need of a separate instrument and provides power measurement with or without power sensors.

**2 Port Transmission  
Measurements (option 001)**

Performance verification of passive and active devices such as filters and amplifiers.

**Bias Tee  
(option 002)**

Supplies up to 32 VDC built-in bias to active devices, such as amplifiers.

**CW Signal Generator  
(option 003)**

Provides a sine wave or continuous wave (CW) source allowing measurements such as repeater's isolation.

**E1/T1 Analyzer  
(Option 004, 005)**

Comprehensive backhaul testing that isolates problems related to the incoming traffic from the fixed network.

**GPS Receiver and Antenna  
(Option 010)**

Provides geographical location and highly accurate frequency and time base enabling precise frequency measurements.

**Interference Analyzer  
(option 011)**

Provides the parameters of spectrogram and a multi-signal RSSI required to properly monitor, identify, and located interference signals. In addition it is capable of generating an audible variable tone accordingly to the signal strength.

**Channel Scanner  
(option 012)**

Intuitive graphical representation of the signal's power for each of the 20 user-definable carriers (frequencies or channels) allowing a fast identification of improper power levels.

**Signal Analyzer  
(option 020 to 029)**

Provides 3GPP/3GPP2/IEEE802.16 conformance for testing for power and spectrum, as well as modulation analysis from 2G to 4G wireless technologies.

**Over The Air Analyzer  
(option 040 to 049)**

Characterizes the transmission quality at any location providing reflective measurements and identifying signals providing from different sites.

## Spectrum Analyzer

The Base Station Analyzers have a general purpose spectrum analyzer which is the most flexible test tool for RF analysis including spectrum monitoring and analysis. The spectrum analysis function provides the capability of one-button standards based power measurements for wireless signals.

- Channel Power
- Adjacent Channel Power
- Occupied Bandwidth
- Spurious Emissions
- Spectrum Emission Mask
- Field Strength

### Specifications

The Base Station Analyzers have one of the best sensitivity and selectivity specifications. With its builtin preamplifier, measurements can be done as low as  $-160$  dBm<sup>1</sup> with a 1 Hz RBW.

Its low SSB phase noise allows detecting very low level spurs or noise signals which are close to the carrier. Its narrow (1 Hz) bandwidth ensures the identification of signals that are very close in frequency.

In addition, the narrow RBW means that the displayed noise level can be reduced improving sensitivity.

Its Auto Sweep time and Auto RBW/VBW allows an easy set up for a fast sweep time while ensuring accurate measurement.

- Frequency Range:
  - 100 kHz to 7.2 GHz (JD7105B)
  - 100 KHz to 4.0 GHz (JD745A)
- DANL (RBW 1 Hz,  $f_c < 1$  GHz)
  - $-145$  dBm<sup>1</sup>
  - $-160$  dBm with preamp<sup>1</sup>
- Sweep Time
  - 80 ms to 1000 s
  - 24  $\mu$ s to 200 s in zero span
- RBW: 1 Hz to 3 MHz
- VBW: 1 Hz to 3 MHz
- SSB Phase Noise
  - $-100$  dBc/Hz @ 30 kHz<sup>1</sup>
  - $-102$  dBc/Hz @ 100 kHz<sup>1</sup>
  - $-115$  dBc/Hz @ 1 MHz<sup>1</sup>

<sup>1</sup>JD7105B specifications

### Capabilities

- Built-in Preamplifier
  - Zero Span with Gated Sweep
  - AM/FM Audio Demodulation
- Multiple Detectors
  - Normal, RMS, Sample Negative, Peak
- Advanced Marker
  - Frequency counter
  - Noise marker
- Limit Line
  - Up to 6 markers and 6 traces

### Measurements

**Channel Power** measures the power level, spectral density and peak to average ratio (PAR) of the signal in a specified channel bandwidth, showing a “Pass” or “Fail” condition according to the defined power.



Channel Power

Spectrum Analyzer (cont'd)

**Occupied Bandwidth** measures the frequency bandwidth that contains the specified percentage of the power, the total integrated power and the occupied power, showing a “Pass” or “Fail” condition according to the defined bandwidth.

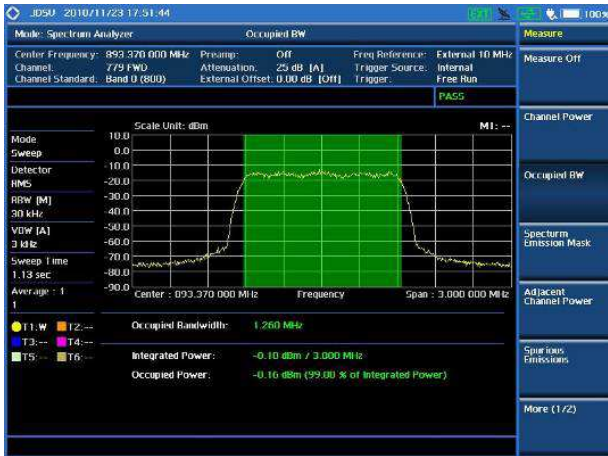

Occupied Bandwidth

**Adjacent Channel Power (ACP)** measures the amount of interference, or power, in adjacent frequencies and its ratios, showing a “Pass” or “Fail” condition according to the defined test condition.



Adjacent Channel Power

**Spectrum Emission Mask (SEM)** compares the total power level within the defined carrier bandwidth and the given offset frequencies to the defined mask limits with “Pass” or “Fail” result.

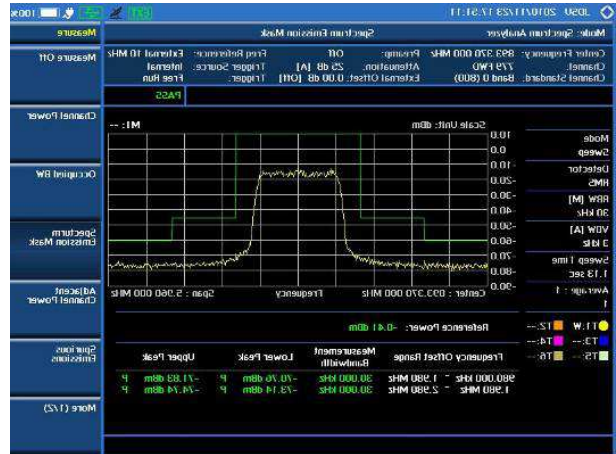

Spectrum Emission Mask

**Spurious Emissions** identifies and determines the power level of spurious emissions in certain frequency bands, showing a "Pass" or "Fail" condition according to the defined mask limits.



Spurious Emissions

**Field Strength** offers quick and convenient field strength measurement and analysis with the userdefinable multi segment line. The field strength measurement is easy to make once the antenna factors are specified in the analyzer.

**AM/FM Audio Demodulation** allows an easy identification of interfering signals. The AM/FM signal can be demodulated into the instrument’s built-in speaker or through a headset.

**Spectrum Analyzer** can be simultaneously operated with CW Signal Generator. It is easily fulfilling the guideline of >100 dB required for repeater and antenna isolation measurement.

## 9

## Cable and Antenna Analyzer

The Base Station Analyzers perform cable and antenna measurements for the verification of base station's infrastructure including feed-lines, connectors, antennas, cables, jumpers, amplifiers, and filters.

The distance-to-fault (DTF) function is capable of locating transmission problems up to 1,500 m (4,921 ft), at a measurements speed of 2 ms/data<sup>1</sup>.

The Base Station Analyzers offer a superior analysis tools including a trace overlay feature allowing a comparison analysis of up to 6 traces, and supporting up to 6 individual markers allocated to any trace.

In addition, it includes a user-configurable marker bands enabling visual identification of uplink and downlink frequencies for compliance verification with a single measurement trace.

## Capabilities

## Reflection

- VSWR
- Return Loss

## DTF

- VSWR
- Return Loss

## Cable Loss (1 port)

- 1 Port Phase
- Smith Chart

## 2 Port Transmission Measurements

## Insertion

- Loss
- High Gain
- Low Gain

## 2 Port Phase

## Measurements

**Reflection** measures the complete cell-site transmission line impedance performance across the frequency range of interest in Voltage Standing Wave Ratio (VSWR) or Return Loss.

**Distance-to-Fault (DTF)** measures fault locations in the transmission system of the cell-site indicating signal discontinuities in VSWR or Return Loss. Use this measurement to precisely pinpoint the location of damaged or degraded antennas, connectors, amplifiers, filters, and duplexers, etc.



## Reflection-Return Loss



## DTF-Return Loss

<sup>1</sup> JD7105B specifications

**Cable and Antenna Analyzer (cont'd)**

**Cable Loss (1 port)** measures the signal loss through a cable or other devices over a defined frequency range. It is sufficient to connect one end of the cable to the instrument measurement port. The other end of the cable is terminated with a short or left open.



Cable Loss (1 port)

**Smith Charts and Phase** measures impedance and phase for proper tuning of RF devices.

Smith charts can be used to display impedance matching characteristics in cable and antenna system as well as filter and duplexers devices.



Smith Chart

**1 Port Phase** measures S11 phase in order to tune antennas and phase match cables.



1 Port Phase

**2 Port Transmission Measurements** which are insertion gain/loss and 2 port phase provide real vector network analysis. Matching and transmission characteristics of filter and amplifiers can be determined quickly and highly accuracy.

**Insertion Gain/Loss** measures the characteristics of passive and active devices such as filters, jumpers, splitters, and amplifiers as well as verifies antenna isolation or sector to sector isolation.



Insertion Loss

**2 Port Phase** measures S21 phase in order to characterise transmitted device.

The optional built-in **Bias Tee** supplies power to active devices through the instrument's RF-In port eliminating the need of an external power supplies.

**Power Meter**

The Base Station Analyzers perform two different methods of power measurement; the first is an internal power measurement for standard power testing without the assistance of external power sensors and the second is interfacing with an external power sensor for high accuracy power measurements.

Internal power measurement	External power measurement	
Frequency Range	Terminating Power Sensor JD732A	Directional (Through Line)
• 10 MHz to 7.2 GHz <sup>1</sup>	• Average Power JD734A	Power Sensor JD731A/JD733A
Dynamic Range	• Peak Power JD736A	• Forward Average Power
• -120 to +30 dBm <sup>1</sup>	• Average and Peak Power	• Forward Peak Power
Measurement Type		• Reverse Average Power
• RMS		• VSWR
• Peak		

The Power Meter function also provides a Pass/Fail condition with user-definable limits. The test results are displayed in dBm and Watts. The power measurement can be set as an absolute measurement displayed in dBm or as a relative measurement displayed in dB.

The JD7105B and JD745A display the power level in two formats, as a real-time power level value in an analog meter, and as a power level trend through time in a histogram chart.

For high-precision power measurements the JD7105B and JD745A interface with external power sensors through a USB connection. There are two types of power sensors:

- Termination Power: Power sensor JD732A, JD734A, or JD736B. For out-of-service testing.
- Directional Power or Through Line: Power sensor JD731A or JD733A. Having the advantage to perform in-service power testing.



Internal power measurement



External Power Measurement



<sup>1</sup>JD7105B specifications

# 12

## Interference Analyzer

The Interference Analyzer (option 11) is the most effective way to locate and identify periodic or intermittent RF interferences. The presence of interference signals are derived from licensed or unlicensed transmitters of many kinds causing dropped calls and poor quality service.

### Measurements

The **Spectrum Analyzer** with an audible indicator is especially useful during the process of locating the interferer source with a directional antenna.



The **audible tone** is proportional to the signal power strength. In addition a built-in AM/FM audio demodulator it provides a convenient identification of AM/FM signals.

**Interference ID** allows an automatic classification of the interfering signal providing a list of possible signal types corresponding to the signal selected.

The **spectrogram** captures spectrum activity over time indicating the power levels of the spectrum with different color identification.

The spectrogram is an effective measurement to identify periodic or intermittent signals. Postprocessing analysis can be done for each measurement over time using a time cursor..

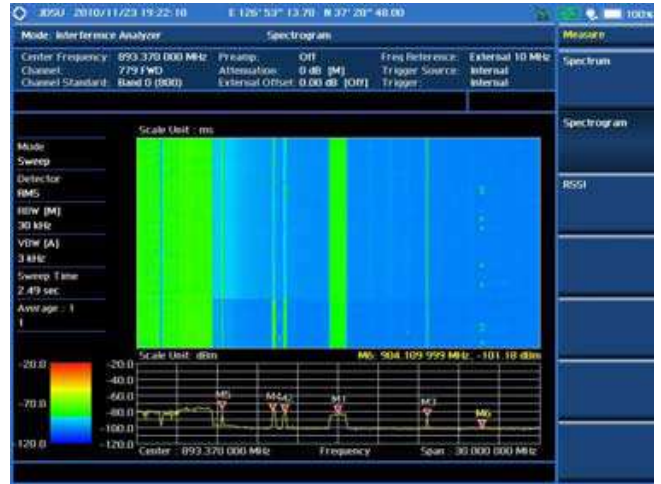

Spectrogram

**Received Signal Strength Indicator (RSSI)** is a multiple signal tracking metric that is particularly useful for measuring power level variations over time.

The RSSI measurement also allows the assignment of power limit line for generating an audible alarm and increasing an alarm counter every time any signal goes beyond the limit line.

For long-term analysis the Spectrogram and RSSI measurements can be automatically saved into an external USB memory. Post-analysis can be done with the application software JDViewer.



Received signal strength indicator

## 13

## Signal Analyzer

The Signal Analyzer performs 3GPP/3GPP2/IEEE802.16 standard compliance testing for power and spectrum, as well as modulation analysis; making RF parametric analysis as well as modulation quality performance of modern wireless communication systems. It performs standard-based measurements with a single-button action, indicating a Pass/Fail condition according to the standard-based or userdefined limits.

The Auto Measure capability in Signal Analyzer creates easily set up testing scenarios, including the programming of measurement schedules such as starting time, duration, intervals and measurement parameters. Based on the user defined conditions, the JD7105B and JD745A perform the tests of up to 10 carriers and automatically store the results.

The Over The Air (OTA) Analyzer function provides over the air measurements for quick performance characterization of the base station. This measurement capability is especially useful in testing cell sites which are not easily accessible or the cell site proactively without interrupting service.

The Signal Analyzer provides following measurement capabilities:

- Spectrum Analysis
- RF Analysis
- Modulation Analysis
- Auto Measure



The **modulation analysis** can be performed in any of the following wireless technologies:

- cdmaOne/CDMA2000 (option 020)
- EV-DO (option 021)
- GSM/GPRS/EDGE (option 022)
- WCDMA/HSDPA (option 023 and 024)
- TD-SCDMA (option 025)
- Mobile WiMAX (option 026)
- LTE - FDD (option 028 )
- LTE - TDD (option 029))



Available **Over The Air (OTA)** analysis are:

- cdmaOne/CDMA2000 (option 040)
- EV-DO (option 041)
- GSM/GPRS/EDGE (option 042)
- WCDMA/HSDPA (option 043)
- TD-SCDMA (option 045)
- Mobile WiMAX (option 046)
- LTE - FDD (option 048)
- LTE - TDD (option 049)

**GSM/GPRS/Edge Signal Analyzer**

The GSM/GPRS/EDGE Signal Analyzer performs power and spectrum measurements as well as modulation analysis in a simple and easy manner with just a few key strokes.

It makes conformance testing according to the specifications (3GPP TS 51.021) providing a simple Pass/Fail indication on each test.

RF and modulation analysis (option 22)		OTA analysis (option 42)
Channel power	Power vs time	Channel scanner
Occupied bandwidth	• Slot	Frequency scanner
Spectrum emission mask	• Frame	Multipath profile
Spurious emissions	Constellation	Modulation analyzer
	Auto measure*	

**Measurements**

**Channel power** measures the total RF power, spectral density and peak to average ratio (PAR) of the signal in a GSM channel bandwidth.

**Occupied bandwidth** measures the frequency bandwidth that contains 99% of the power, measuring the total integrated power and the occupied power.

The **spectrum emission mask (SEM)** compares the total power level within the defined carrier bandwidth and the given offset channels according to the standards.



GSM spectrum emission mask

**Spurious emissions** identifies and determines the power level of spurious emissions in certain frequency bands.

**Power vs. time (slot)** measures the modulation envelope in the time domain showing the signal rise and fall shape of GSM format.

**I-Q constellation** verifies the modulation quality including phase errors and I-Q origin offsets characterizing the modulation quality of GSM.

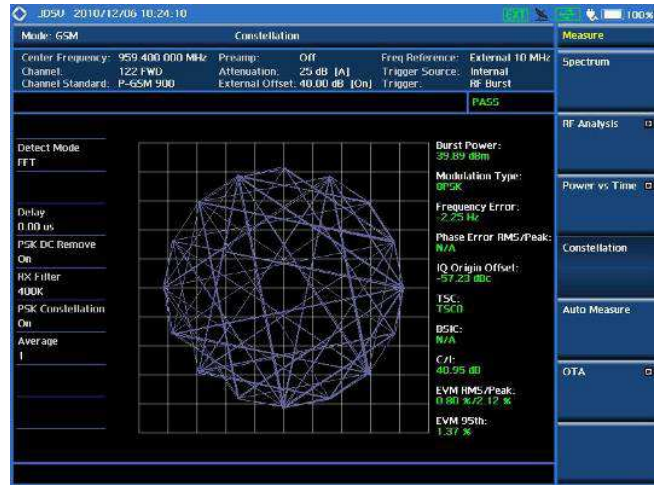

GSM constellation

**Over the air analyzer** provides signal performance metrics at any point in the area served by the base station, including multi-path profile indicating the strength of reflected signals; as well as carrier over interference histogram indicating the signal strength variation.



GSM OTA modulation analyzer

**WCDMA/HSDPA Signal Analyzer**

The WCDMA/HSDPA Signal Analyzer perform power and spectrum measurements, as well as modulation analysis in a simple and easy manner with just a few key strokes.

It performs conformance testing according to the following standards providing a simple Pass/Fail indication on each test.

- 3GPP TS 25.104. Base station radio transmission and reception (FDD).
- 3GPP TS 25.141. Base station (BS) conformance test (FDD).
- 3GPP TS 25.211. Physical channel and mapping of transport channels onto physical channels (FDD).
- 3GPP TS 25.212. Multiplexing and channel coding (FDD).
- 3GPP TS 25.213. Spreading and modulation (FDD).

**RF and modulation Analysis (option23/24) OTA analysis (option 43)**

Channel power	Constellation	Channel Scanner
Occupied bandwidth	Code domain power	Scramble Scanner
Spectrum emission mask	Codogram	Multipath Profile
ACL	RCSI	Code Domain Power
Multi-ACL	CDP table	
Spurious emissions	Auto measure	
	Power Statistics	
	CCDF	

**Measurements**

**Channel power** measures the total RF power, spectral density and peak to average ratio (PAR) of the signal in a WCDMA channel bandwidth.

**Occupied bandwidth** measures the frequency bandwidth that contains 99% of the power, measuring the total integrated power and the occupied power.



WCDMA channel power

**Spectrum Emission Mask (SEM)** compares the total power level within the defined carrier bandwidth and the given offset frequencies on both sides of the carrier frequency to levels allowed by the standards.

**Adjacent channel leakage power ratio (ACLR)** measures the amount of interference, or power, in an adjacent frequency channel according to the standards.



WCDMA ACLR

**Spurious emissions** identifies and determines the power level of spurious emissions in certain frequency bands.

The **constellation** measurement displays the I-Q constellation diagram with modulation metrics to characterize the transmitter's modulation performance.



WCDMA constellation

WCDMA/HSDPA Signal Analyzer (cont'd)

**Code domain power (CDP)** measures power levels of the spread code channels across WCDMA RF channel, normalized to the total WCDMA power.

CDP shows the physical channels of the WCDMA signal, and identifies the various spread factors by different color types, making it easy to differentiate traffic types carried in the WCDMA signal.



WCDMA code domain power

The **codogram** displays the power variation for every code over time, presenting a clear view of the traffic load per channels at any given time.

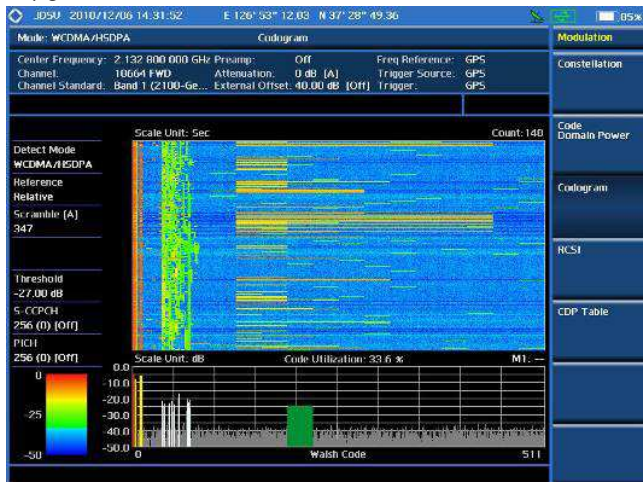

WCDMA codogram

**Received code signal indicator (RCSI)** shows the power variation over time of WCDMA control channels: CPICH, PCCPCH, SCCPCH, PICH, PSCH, and SSCH.

For long-term analysis the codogram and RCSI measurements can be automatically saved into an external USB memory, post-analysis can be done with the application software JDViewer.

The **Complementary Cumulative Distribution Function (CCDF)** characterizes the statistical power level distribution of WCDMA at any given time.

The **OTA analyzer** covers three key parameters: scramble scanner, multipath profile and code domain power.

The code domain power in OTA analyzer shows not only modulation performance metrics but also amplifier capacity and code utilization metrics.



WCDMA OTA code domain power

**cdmaOne/CDMA2000 Signal Analyzer**

The cdmaOne/CDMA2000 Signal Analyzer performs power and spectrum measurements, as well as modulation analysis in a simple and easy manner with just a few key strokes.

It performs conformance testing according to the following standards providing a simple Pass/Fail indication on each test.

- 3GPP2 C.S0002. Physical Layer Standard for CDMA2000 Spread Spectrum Systems
- 3GPP2 C.S0010. Recommended Minimum Performance Standards for CDMA2000 Spread Spectrum Base Station

RF and modulation analysis (option20)		OTA analysis (option 40)
Channel Power	Constellation	Channel Scanner
Occupied Bandwidth	Code Domain	PN Scanner
Spectrum Emission Mask	Power	Multipath Profile
Mask	Codogram	Code Domain Power
ACPR	RCSI	
Multi-ACPR	CDP Table	
Spurious Emissions	Auto Measure	
	Power Statistics	
	CCDF	

**Measurements**

**Channel Power** measures the total RF power, spectral density and peak to average ratio (PAR) of the signal in a cdmaOne or CDMA2000 channel bandwidth.

**Occupied Bandwidth** measures the frequency bandwidth that contains 99% of the power, measuring the total integrated power and the occupied power.



CDMA occupied bandwidth

**Spectrum Emission Mask (SEM)** compares the total power level within the defined carrier bandwidth and the given offset frequencies on both sides of the carrier frequency to levels allowed by the standards.

**Adjacent Channel Power Ratio (ACPR)** measures the amount of interference, or power, in adjacent frequencies and its ratios specified by the standards.



CDMA ACPR

**Spurious emissions** measurement identifies and determines the power level of spurious emissions in certain frequency bands.

The **constellation** measurement displays the I-Q constellation diagram with modulation metrics to characterize the transmitter's modulation performance.

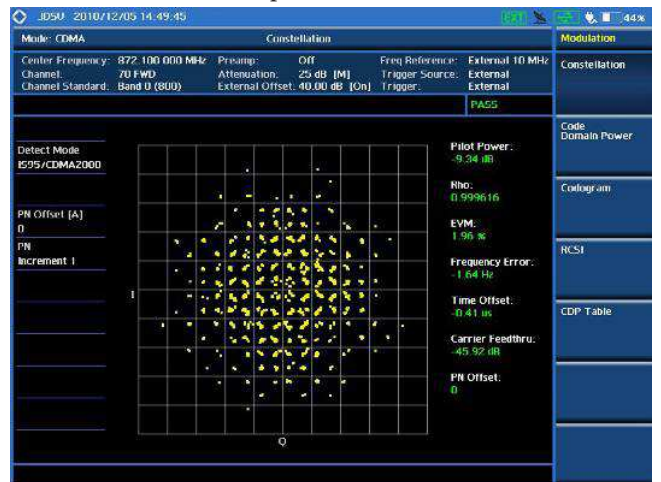

CDMA constellation

cdmaOne/CDMA2000 Signal Analyzer (cont'd)

**Code domain power (CDP)** measures power levels of the spread code channels across cdmaOne or CDMA2000 RF channel, normalized to the total CDMA power.

CDP shows the physical channels of the cdmaOne or CDMA2000, and identifies the various spread factors by different color types, making it easy to differentiate traffic types carried in the CDMA signal.

The **codogram** displays the power variation for every code over time, presenting a clear view of the traffic load per channel at any given time.

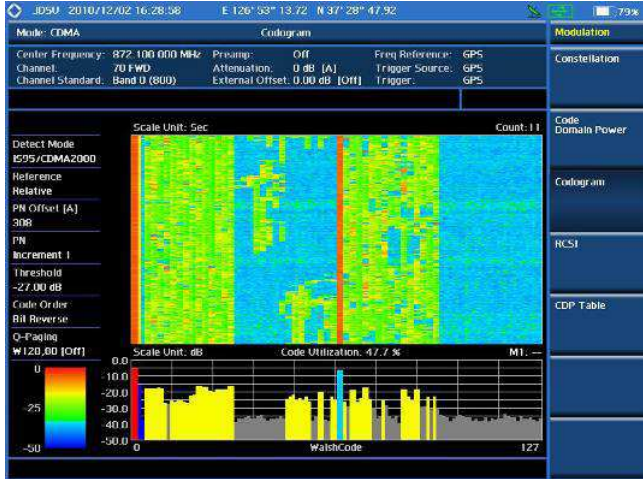

CDMA codogram

**Received code signal indicator (RCSI)** shows the power variation over time of cdmaOne or CDMA2000 control channels: Pilot, page, sync and quick page.

For long-term analysis the codogram and RCSI measurements can be automatically saved into an external USB memory, Post-analysis can be done with the application software JDViewer.



CDMA received code strength indicator

The **complementary cumulative distribution function (CCDF)** characterizes the statistical power level distribution of cdmaOne or CDMA2000 at any given time.

The **OTA analyzer** covers four key parameters: channel scanner, PN scanner, multipath profile and code domain power.

The code domain power in OTA analyzer shows not only modulation performance metrics but also amplifier capacity and code utilization metrics.

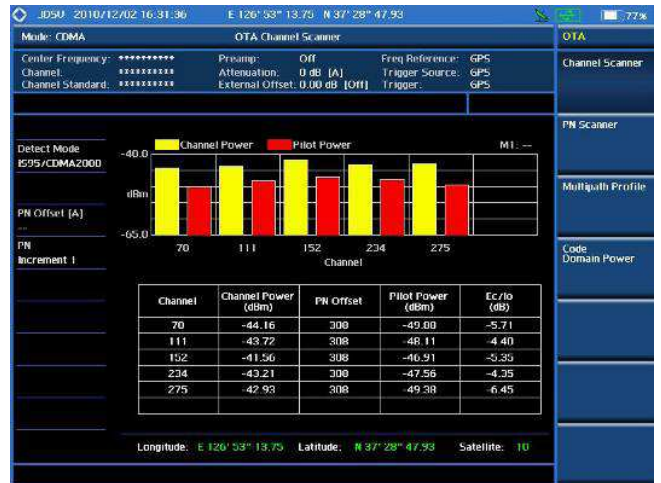

CDMA OTA channel scanner

EV-DO Signal Analyzer

The EV-DO Signal Analyzer performs power and spectrum measurements, as well as modulation analysis in a simple and easy manner with just a few key strokes.

It performs conformance testing according to the following standards providing a simple Pass/Fail indication on each test.

- 3GPP2 C.S0024-B. CDMA2000 High Rate Packet Data Air Interface Specification
- 3GPP2 C.S0032-B. Recommended Minimum Performance Standards for CDMA2000 High Rate Packet Data Access Network

RF and modulation analysis (option21)		OTA analysis (option 41)
Channel Power	Constellation	Channel Scanner
Occupied Bandwidth	Composite 64,	PN Scanner
Spectrum Emission	Composite 128	Multipath Profile
Mask	Pilot, MAC 64, MAC	Code Domain Power
ACPR	128, Data	
Multi-ACPR	Code Domain Power	
Spurious Emissions	Pilot, MAC 64, MAC	
Power vs. Time	128, Data	
• Idle Slot	MAC Codogram	
• Active Slot	RCSI	
	MAC CDP Table	
	Auto Measure	
	Power Statistics	
	CCDF	

Measurements

**Channel power** measures the total RF power, spectral density and peak to average ratio (PAR) of the signal in a EV-DO channel bandwidth.

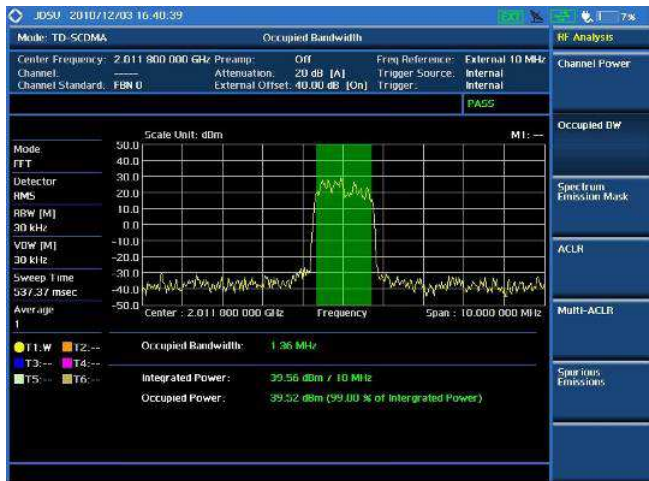

EV-DO channel power

**Occupied bandwidth** measures the frequency bandwidth that contains 99% of the power, measuring the total integrated power and the occupied power.



EV-DO occupied bandwidth

The **spectrum emission mask (SEM)** compares the total power level within the defined carrier bandwidth and the given offset frequencies on both sides of the carrier frequency to levels allowed by the standards.

**Adjacent channel power ratio (ACPR)** measures the amount of interference, or power, in an adjacent frequency channel specified by the standard.

**Spurious emissions** measurement identifies and determines the power level of spurious emissions in certain frequency bands.

**Power vs. time (slot)** verifies that the transmitter output power has the correct amplitude, shape, and timing for EV-DO format.



EV-DO Power vs. Time (Idle Slot)

EV-DO Signal Analyzer (cont'd)

The **constellation** measurement displays the I-Q constellation diagram with modulation metrics to characterize the transmitter's modulation performance.

**Code domain power (CDP)** measures power levels of the spread code channels across EV-DO channels, normalized to the total EV-DO power.

**CDP pilot/MAC** displays the power of various demodulated codes in the pilot/MAC channel.

**CDP data** displays the power of the 16 subchannels of the data channel separately.



EV-DO data code domain

The **MAC codogram** displays the power variation for every code over time, presenting a clear view of the traffic load per channels at any given time.

**Received code signal indicator (RCSI)** shows the power variation over time of EV-DO channels: Pilot, MAC, data, and slot.

For long-term analysis the codogram and RCSI measurements can be automatically saved into an external USB memory. Post-analysis can be done with the application software JDViewer.



EV-DO received codestrength indicator

The **complementary cumulative distribution function (CCDF)** characterizes the statistical power level distribution of EV-DO at any given time.

The **over the air (OTA) analyzer** covers four key parameters: channel scanner, pilot scanner, multipath profile, and code domain power.



EV-DO OTA PN scanner

**TD-SCDM Signal Analyzer**

The TD-SCDMA Signal Analyzer performs power and spectrum measurements, as well as modulation analysis in a simple and easy manner with just a few key strokes.

It performs conformance testing according to the following standards providing a simple Pass/Fail indication on each test.

- 3GPP TS 25.105. Base Station radio transmission and reception (TDD)
- 3GPP TS 25.142. Base Station conformance testing (TDD)
- 3GPP TS 25.222. Multiplexing and channel coding (TDD)
- 3GPP TS 25.223. Spreading and modulation (TDD)

RF and modulation analysis (option 25)		OTA analysis (option 45)
Channel Power	Power vs. Time	Sync-DL ID Scanner
Occupied Bandwidth	• Slot, Frame	Sync-DL ID vs. Tau
Spectrum Emission Mask	• Mask, Timogram	Sync-DL ID Multipath
Mask	Constellation	Sync-DL ID Analyzer
ACLR	Midamble Power	
Multi-ACLR	Code Power	
Spurious Emissions	Code Error	
	Auto Measure	

**Measurements**

**Channel power** measures the total RF power, spectral density and peak to average ratio (PAR) of the signal in a TD-SCDMA channel bandwidth.

**Occupied bandwidth** measures the frequency bandwidth that contains 99% of the power, measuring the total integrated power and the occupied frequency.



TD-SCDMA Occupied Bandwidth

The **spectrum emission mask (SEM)** compares the total power level within the defined carrier bandwidth and the given offset channels according to the standards.



TD-SCDMA spectrum emission mask

**Adjacent channel power ratio (ACPR)** measures the amount of interference, or power, in an adjacent frequency channel according to the standards.

**Spurious emissions** identifies and determines the power level of spurious emissions in certain frequency bands.

**Power vs. time** verifies that the transmitter output power has the correct amplitude, shape, and timing for TD-SCDMA format.

The **Timogram** displays and shows how power level changes over time making it easier to see UpPTS and DwPTS activity over time, identifying interference on UpPTS by the DwPTS transmitted from adjacent base stations.



TD-SCDMA power vs. time (frame)

**TD-SCDM Signal Analyzer (cont'd)**

The **Constellation** measurement displays the I-Q constellation diagram with modulation metrics to characterize the transmitter's modulation performance.



TD-SCDMA constellation

**Code Power** provides the power data for an individual code channel and layer for a specified time slot. It displays the power of the 16 codes of a TD-SCDMA signal.



TD-SCDMA code power

**Code Error** shows the power data and error data for an individual code channel and layer for a specified time slot simultaneously.

The **over the air (OTA) analyzer** provides four essential measurements: sync-DL ID scanner, sync-DL ID multipath and sync-DL ID analyzer.

Over The Air Analyzer provides signal performance metrics at any point in the area served by the base station, including multipath profile indicating the strength of reflected signals; as well as carrier over ID histogram indicating the signal strength variation.



TD-SCDMA OTA sync-DL ID analyzer

**Mobile WiMAX Signal Analyzer**

The Mobile WiMAX Signal Analyzer performs power measurements and spectrum measurements, as well as modulation analysis in a simple and easy manner with just a few key strokes.

It performs conformance testing according to the following standards providing a simple Pass/Fail indication on each test.

- IEEE 802.16e-2005
- WiBro (Korean Mobile WiMAX OFDMA Service)

RF and modulation analysis (option 26)		OTA Analysis (option 46)
Channel Power	Constellation	Preamble Scanner
Occupied Bandwidth	Spectral Flatness	Multipath Profile
Spectrum Emission Mask	EVM vs. Subcarrier	Preamble Power
Spurious Emissions	EVM vs. Symbol	Trend
Power vs. Time (Frame)	Auto Measure	
	Power Statistics CCDF	

**Measurements**

**Channel power** measures the total RF power, spectral density and peak to average ratio (PAR) of the signal in a Mobile WiMAX channel bandwidth.



WiMAX channel power

**Occupied bandwidth** measures the frequency bandwidth that contains 99% of the power, measuring the total integrated power and the occupied power.

The **spectrum emission mask (SEM)** compares the total power level within the defined carrier bandwidth and the given offset channels according to the standards.



WiMAX spectrum emission mask

**Spurious emissions** identifies and determines the power level of spurious emissions in certain frequency bands.

**Power vs. time (frame)** verifies that the transmitter output power has the correct amplitude, shape, and timing according to the standards.



WiMAX Power vs. time (frame)

Mobile WiMAX Signal Analyzer (cont'd)

The **constellation** measurement displays the I-Q constellation diagram with modulation metrics to characterize the transmitter's modulation performance.



WiMAX constellation

**Spectral flatness** measures the flatness energy of the constellation according to WiMAX specification IEEE-816e.



WiMAX spectral flatness

**EVM vs. sub-carrier** shows the error vector magnitude representing the average constellation error of WiMAX OFDMA subcarriers.

**EVM vs. symbol** shows the error vector magnitude representing the average constellation error of WiMAX OFDMA symbols.



WiMAX OTA preamble scanner

The **complementary cumulative distribution function (CCDF)** characterizes the statistical power level distribution of WiMAX at any given time.

The **Over The Air (OTA) Analyzer** provides three essential measurements: preamble scanner, multipath profile, and preamble Power Trend.

Over The Air Analyzer provides cell ID, sector ID and preamble at any point in the area served by the base station, including multipath profile indicating the strength of reflected signals; as well as carrier over interference histogram indicating the signal strength variation.

**LTE-FDD Signal Analyzer**

The LTE Signal Analyzer performs power measurements and spectrum measurements, as well as modulation analysis in a simple and easy manner with just a few key strokes.

It performs conformance testing according to the following standards providing a simple Pass/Fail indication on each test.

- 3GPP TS 36.104. Evolved Universal Terrestrial Radio Access (E-UTRA); Base Station (BS) Radio Transmission and Reception
- 3GPP TS 36.141. Evolved Universal Terrestrial Radio Access (E-UTRA); Base Station (BS) Conformance Testing
- 3GPP TS 36.211. Evolved Universal Terrestrial Radio Access (E-UTRA); Physical Channels and Modulation
- 3GPP TS 36.212. Evolved Universal Terrestrial Radio Access (E-UTRA); Multiplexing and Channel Coding.

RF and Modulation Analysis (option 28)		OTA Analysis (option 48)
Channel Power	Data Channel	ID Scanner
Occupied Bandwidth	Summary	Multipath Profile
Spectrum Emission Mask	Control Channel	Control Channel
ACLR	Summary	
Spurious Emissions	Subframe Summary	
Power vs. Time (Frame)	Frame Summary	
	Auto Measure	
	Power Statistics CCDF	

**Measurements**

**Channel power** measures the power level and spectral density of the signal in a LTE channel bandwidth.



LTE channel power

**Occupied bandwidth** measures the frequency bandwidth that contains 99% of the power, measuring the total integrated power and the occupied frequency.

The **spectrum emission mask (SEM)** compares the total power level within the defined carrier bandwidth and the given offset channels according to the standards.

**Adjacent channel leakage power ratio (ACLR)** measures the amount of interference, or power, in an adjacent frequency channel according to the standards.



LTE adjacent channel leakage power ratio

**Spurious emissions** identifies and determines the power level of spurious emissions in certain frequency bands.

**Power vs. time (frame)** measures the modulation envelope in the time domain, showing the power of each time slot in an LTE signal.

LTE Signal Analyzer (cont'd)

**Data channel summary** measures the constellation for the specified resource block as well as the modulation accuracy of each PDSCHs' at the specified sub-frame.



LTE data channel summary

**Control channel summary** measures the constellation for the specified control channel as well as modulation accuracy of the control channel at the specified sub-frame.



LTE control channel summary

**Sub-frame summary** measures the modulation accuracy of all the data and control channels at the specified sub frame.



LTE frame summary

**Frame summary** measures the modulation accuracy of all the data and control channels at of the frame.

The **complementary cumulative distribution function (CCDF)** characterizes the statistical power level distribution of LTE at any given time.

**Over The Air Analyzer** provides signal performance metrics at any point in the area served by the base station, including multipath profile indicating the strength of reflected signals; as well as RS histogram indicating the signal strength variation.



LTE OTA control channel

**LTE-TDD Signal Analyzer**

The LTE Signal Analyzer performs power measurements and spectrum measurements, as well as modulation analysis in a simple and easy manner with just a few key strokes.

It performs conformance testing according to the following standards providing a simple Pass/Fail indication on each test.

- 3GPP TS 36.104. Evolved Universal Terrestrial Radio Access (E-UTRA); Base Station (BS) Radio Transmission and Reception
- 3GPP TS 36.141. Evolved Universal Terrestrial Radio Access (E-UTRA); Base Station (BS) Conformance Testing
- 3GPP TS 36.211. Evolved Universal Terrestrial Radio Access (E-UTRA); Physical Channels and Modulation
- 3GPP TS 36.212. Evolved Universal Terrestrial Radio Access (E-UTRA); Multiplexing and Channel Coding

RF and Modulation Analysis (option 29)		OTA Analysis (option 49)
Channel Power	Data Channel	ID Scanner
Occupied Bandwidth	Summary	Multipath Profile
Spectrum Emission Mask	Control Channel	Control Channel
ACLR	Summary	
Spurious Emissions	Subframe Summary	
Power vs. Time (Slot)	Auto Measure	
Power vs. Time (Frame)	Power Statistics CCDF	

**Measurements**

**Channel Power** measures the total RF power, spectral density, and peak to average ratio (PAR) of the signal in a LTE channel bandwidth.

**Occupied Bandwidth** measures the frequency bandwidth that contains 99% of the power, measuring the total integrated power and the occupied power.



LTE occupied bandwidth

**Spectrum Emission Mask (SEM)** compares the total power level within the defined carrier bandwidth and the given offset frequencies on both sides of the carrier frequency to levels allowed by the standards.



LTE spectrum emission mask

**Adjacent Channel Leakage power Ratio (ACLR)** measures the amount of interference, or power, in adjacent frequencies and its ratios specified the standards.

**Spurious Emissions** identifies and determines the power level of spurious emissions in certain frequency bands

**Power vs. Time (Frame)** measures the modulation envelope in the time domain, showing the power of each time slot in an LTE signal.



LTE Power vs. Time (Frame)

**Power vs. Time (Slot)** measures the modulation envelope in the time domain, showing the signal rise and fall shape of LTE signal.

LTE-TDD Signal Analyzer (cont'd)

**Data Channel Summary** measures the constellation for the specified resource block as well as the modulation accuracy of each PDSCH's at the specified subframe.



LTE data channel summary

**Control Channel Summary** measures the constellation for the specified control channels as well as modulation accuracy of the control channels at the specified subframe.

**Subframe Summary** measures the modulation accuracy of all the data and control channels at the specified subframe.



LTE subframe summary

The **Complementary Cumulative Distribution Function (CCDF)** characterizes the statistical power level distribution of LTE at any given time.

**Over The Air Analyzer** provides signal performance metrics at any point in the area served by the base station, including multipath profile indicating the strength of reflected signals; as well as RS histogram indicating the signal strength variation.



LTE OTA control channel

**E1/T1 Analyzer**

The JD7105B and JD745A perform a simple E1/T1 testing solution for the cell site's circuit-based backhaul.

The E1/T1 Analyzer provides enough flexibility to configure the PDH signal including its framing and coding, as well as the pattern that the instrument will be transmitting.

In addition, the JD7105B and JD745A are capable of automatically logging events.

E1 Analyzer <sup>1</sup>	T1 Analyzer <sup>1</sup>
Monitoring	Monitoring
<ul style="list-style-type: none"> <li>Signal, Sync Loss</li> <li>Alarm</li> <li>Error</li> </ul>	<ul style="list-style-type: none"> <li>Signal, Sync Loss</li> <li>Alarm</li> <li>Error</li> </ul>
BERT (PCM 31 only)	RX Signal Level BERT Loop



T1 RX Signal Level



E1 Monitoring



T1 BERT



E1 BERT

<sup>1</sup> See ordering information section for detail option

**Channel Scanner**

The Channel Scanner function (option 12) is capable of measuring up to 20 independent channels, of any cellular technology, at any frequency channel or frequency.

The channel scanner function provides a simple view of the power level of each signal type.



Channel scanner

**GPS Receiver and Antenna**

The GPS Receiver (option 11) provides position location (latitude, longitude and altitude), as well as timing for highly accurate frequency measurement, allowing an independent verification of base station timing.



JD7105B with GPS antenna

**Application Software**

The JD7105B and JD745A communicate with the PC application software JDViewer to retrieve measurements and perform post-processing analysis and reporting.

**Features**

- Communicates with the JD7105B and JD745A via LAN or USB.
- Retrieves measured or saved measurements.
- Exports measurement results.
- Generates and prints configurable reports.
- Edits measurement charts.
- Creates a composite file of multiple spectrogram traces.
- Analyzes measurement results allowing the assignment of multiple markers and limit lines.
- Creates user defined settings for channel power, occupied BW, spectrum emission mask, and adjacent channel power measurements.
- Registers or edits user definable cable types into the instrument's custom cable lists.
- Registers or edits user definable frequency bands into the instrument's custom bands lists.
- Creates or edits multi-segment lines for insertion gain and loss measurements.
- Superimposes up to 4 traces on one measurement graph.
- Creates Auto Measure scenarios for multi-carrier signal analysis.

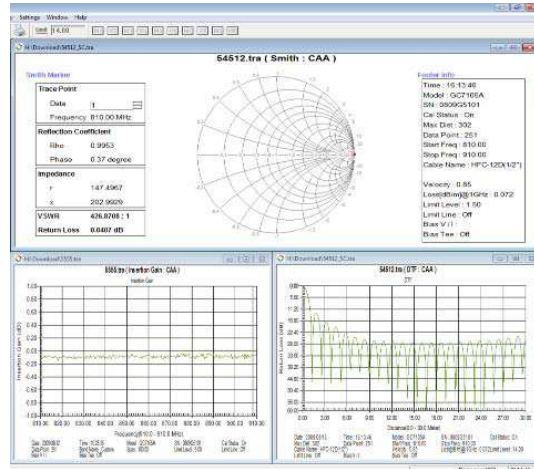

JDViewer, VSWR, DTF, Smith chart



JDViewer spectrum, demodulation

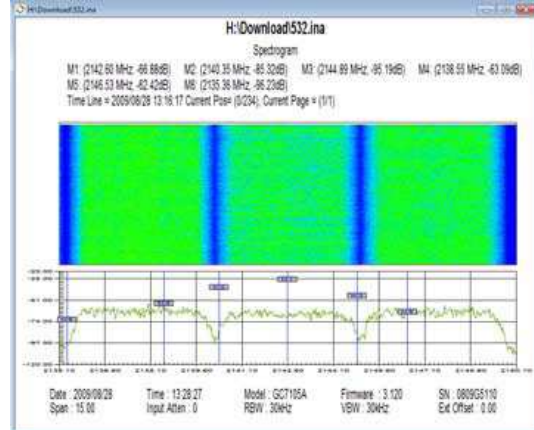

JDViewer spectrum, RSSI

## Ordering information



## JDSU Base Station Analyzer Family



Features	JD7105B	JD745A
Spectrum Analyzer	100 kHz to 7.2 GHz	100 kHz to 4.0 GHz
Cable and Antenna Analyzer	25 MHz to 4.0 GHz	5 MHz to 4.0 GHz
2 Port Transmission Measurements	Standard	Option 001
Bias Tee (Internal)	Option 013	Option 002
Power Meter		
RF Power Meter (Internal)	Standard	Standard
RF Power Meter (External)	Required External Power Sensors	Required External Power Sensors
CW Signal Generator	Standard	Option 003
	3 dBm, -20 to -70 dBm (10 dB steps)	0 dBm, -30 to -80 dBm (1 dB steps)
GPS Receiver and Antenna	Option 010	Option 010
Interference Analyzer	Option 011	Option 011
Channel Scanner	Option 012	Option 012
E1 Analyzer	Option 002	Option 004
T1 Analyzer	Option 003	Option 005
Signal Analyzer	20 MHz Demodulation Hardware	20 MHz Demodulation Hardware



**Ordering information****JD7105B**

100 kHz to 7.2 GHz	Spectrum analyzer	
25 MHz to 4 GHz	Cable and Antenna Analyzer <sup>1</sup>	
10 MHz to 7.2 GHz	Power meter,	Internal mode

**Options**

NOTE: Upgrade options for the JD7105B use the designation JD7105BU before the respective last two digit option number.

JD7105B002	E1 Analyzer <sup>2</sup>	
JD7105B003	T1 Analyzer <sup>2</sup>	
JD7108B010	GPS Receiver and Antenna	
JD7108B011	Interference Analyzer <sup>3,4</sup>	
JD7108B012	Channel Scanner	
JD7105B013	Bias Tee	
JD7108B020	cdmaOne/CDMA2000 Signal Analyzer	
JD7108B021	EV-DO Signal Analyzer	Requires option 20
JD7108B022	GSM/GPRS/EDGE Signal Analyzer	
JD7108B023	WCDMA Signal Analyzer	
JD7108B024	HSDPA Signal Analyzer	Requires option 23
JD7108B025	TD-SCDMA Signal Analyzer	
JD7108B026	Mobile WiMAX Signal Analyzer	
JD7108B028	LTE - FDD Signal Analyzer	
JD7108B029	LTE - TDD Signal Analyzer	
JD7108B040	cdmaOne/CDMA2000 OTA Analyzer <sup>4</sup>	Requires options 10 and 20
JD7108B041	EV-DO OTA Analyzer <sup>4</sup>	Requires options 10 and 21
JD7108B042	GSM/GPRS/EDGE OTA Analyzer <sup>4</sup>	Requires options 10 and 22
JD7108B043	WCDMA/HSDPA OTA Analyzer <sup>4</sup>	Requires options 10 and 23/24
JD7108B045	TD-SCDMA OTA Analyzer <sup>4</sup>	Requires options 10 and 25
JD7108B046	Mobile WiMAX OTA Analyzer <sup>4</sup>	Requires options 10 and 26
JD7108B048	LTE OTA - FDD Analyzer <sup>2</sup>	Requires options 10 and 028
JD7108B049	LTE OTA - TDD Analyzer <sup>2</sup>	Requires options 10 and 029

<sup>1</sup>Requires Calibration Kit

<sup>2</sup>Requires Test Cable

<sup>3</sup>Highly recommends adding JD7108B010

<sup>4</sup>Highly recommends adding G70005035x or/and G7000-5036x

**Standard Accessories**

JD71050341	JD 7100 Soft Carrying Case <sup>5</sup>
G710550326	AC/DC Power Adapter <sup>5</sup>
G710550335	Cross LAN Cable (1.5m) <sup>5</sup>
GC73050515	USB A to B Cable (1.8m) <sup>5</sup>
GC72450518	>1 GByte USB Memory <sup>5</sup>
G710550325	Rechargeable Lithium Ion Battery <sup>5</sup>
G710550323	Automotive Cigarette Lighter 12 VCD Adapter <sup>5</sup>
JD7108B361	JD7105B User's Manual and Application Software –CD

<sup>5</sup>Standard accessories can be purchased separately.

**Ordering information****JD745A**

100 kHz to 4 GHz	Spectrum analyzer	
5 MHz to 4 GHz	Cable and Antenna Analyzer <sup>1</sup>	
10 MHz to 4 GHz	Power meter,	Internal mode

**Options**

NOTE: Upgrade options for the JD745A use the designation JD745AU before the respective last three digit option number.

JD745A001	2 Port Transmission Measurements <sup>2</sup>	
JD745A002	Bias Tee	Requires option 02
JD745A003	CW Signal Generator	
JD745A004	E1 Analyzer <sup>3</sup>	
JD745A005	T1 Analyzer <sup>3</sup>	
JD7108B010	GPS Receiver and Antenna	
JD7108B011	Interference Analyzer <sup>3,4</sup>	
JD7108B012	Channel Scanner	
JD7108B020	cdmaOne/CDMA2000 Signal Analyzer	
JD7108B021	EV-DO Signal Analyzer	Requires option 20
JD7108B022	GSM/GPRS/EDGE Signal Analyzer	
JD7108B023	WCDMA Signal Analyzer	
JD7108B024	HSDPA Signal Analyzer	Requires option 23
JD7108B025	TD-SCDMA Signal Analyzer	
JD7108B026	Mobile WiMAX Signal Analyzer	
JD7108B028	LTE Signal Analyzer	
JD7108B029	LTE - TDD Signal Analyzer	
JD7108B040	cdmaOne/CDMA2000 OTA Analyzer <sup>4</sup>	Requires options 10 and 20
JD7108B041	EV-DO OTA Analyzer <sup>4</sup>	Requires options 10 and 21
JD7108B042	GSM/GPRS/EDGE OTA Analyzer <sup>4</sup>	Requires options 10 and 22
JD7108B043	WCDMA/HSDPA OTA Analyzer <sup>4</sup>	Requires options 10 and 23/24
JD7108B045	TD-SCDMA OTA Analyzer <sup>4</sup>	Requires options 10 and 25
JD7108B046	Mobile WiMAX OTA Analyzer <sup>4</sup>	Requires options 10 and 26
JD7108B048	LTE - FDD OTA Analyzer <sup>2</sup>	Requires options 10 and 028
JD7108B049	LTE - TDD OTA Analyzer <sup>2</sup>	Requires options 10 and 029

<sup>1</sup>Requires Calibration Kit

<sup>2</sup>Requires Dual port Calibration Kit

<sup>3</sup>Highly recommends adding JD7108B010

<sup>4</sup>Highly recommends adding G70005035x or/and G7000-5036x

**Standard Accessories**

G710550326	AC/DC Power Adapter <sup>5</sup>
G710550335	Cross LAN Cable (1.5m) <sup>5</sup>
GC73050515	USB A to B Cable (1.8m) <sup>5</sup>
GC72450518	>1 GByte USB Memory <sup>5</sup>
G710550325	Rechargeable Lithium Ion Battery <sup>5</sup>
G710550323	Automotive Cigarette Lighter 12 VCD Adapter <sup>5</sup>
JD7108B361	JD745A User's Manual and Application Software –CD

<sup>5</sup> Standard accessories can be purchased separately.

**Ordering information****Optional Power Sensors**

JD731A	Directional Power Sensor (peak and average power) Frequency: 300 MHz to 3.8 GHz Power: Average 0.15 to 150 W, Peak 4 to 400 W
JD733A	Directional Power Sensor (peak and average power) Frequency: 150 MHz to 3.5 GHz Power: Average/Peak 0.25 to 50 W
JD732A	Terminating Power Sensor (average power) Frequency: 20 MHz to 3.8 GHz Power: -30 to +20 dBm
JD734A	Terminating Power Sensor (peak power) Frequency: 20 MHz to 3.8 GHz Power: -30 to +20 dBm
JD736A	Terminating Power Sensor (peak and average power) Frequency: 20 MHz to 3.8 GHz Power: -30 to +20 dBm

**Optional Calibration Kits**

JD72450509	Y - Calibration Kit, Type-N(m), DC to 4 GHz, 50 $\Omega$
JD72450510	Y - Calibration Kit DIN(m), DC to 4 GHz, 50 $\Omega$
JD71050507	Dual Port Type-N Calibration Kit, 50 $\Omega$ - Y - Calibration Kit, Type-N(m), DC to 4 GHz, 50 $\Omega$ - Two Adapters Type-N(f) to Type-N(f), DC to 4 GHz, 50 $\Omega$ - Two 1 m RF Test Cables, Type-N(m) to Type-N(m), DC to 18 GHz, 50 $\Omega$
JD71050508	Dual Port DIN Calibration Kit, 50 $\Omega$ - Y - Calibration Kit DIN(m), DC to 4 GHz, 50 $\Omega$ - Two 1 m RF Test Cables, Type-N(m) to Type-N(m), DC to 18 GHz, 50 $\Omega$ - Adapter Type-N(f) to DIN(f), DC to 4 GHz, 50 $\Omega$ - Adapter Type-N(f) to DIN(m), DC to 4 GHz, 50 $\Omega$ - Adapter DIN(f) to DIN(f), DC to 4 GHz, 50 $\Omega$ - Adapter DIN(m) to DIN(m), DC to 4 GHz, 50 $\Omega$

**Optional RF Cables**

G710050531	1.5 m (4.92ft) Precision RF Cable, DC to 18 GHz N(m)-N(f), 50 $\Omega$
G710050532	3.0 m (9.84 ft) Precision RF Cable, DC to 18 GHz N(m)-N(f), 50 $\Omega$

**Optional Omni Antennas**

G700050351	RF Omni Antenna 400 to 450 MHz
G700050352	RF Omni Antenna 450 to 500 MHz
G700050353	RF Omni Antenna 806 to 896 MHz
G700050354	RF Omni Antenna 870 to 960 MHz
G700050355	RF Omni Antenna 1710 to 2170 MHz

**Optional Yaggi Antennas**

G700050364	RF Yaggi Antenna 806 to 896 MHz
G700050365	RF Yaggi Antenna 866 to 960 MHz
G700050363	RF Yaggi Antenna 1750 to 2390 MHz

**Ordering information**
**Optional Adapters**

G710050571	Adapter N(m) to DIN(f), DC to 4 GHz, 50 Ω
G710050572	Adapter DIN(m) to DIN(m), DC to 4 GHz, 50 Ω
G710050573	Adapter N(m) to SMA(f), DC to 18 GHz, 50 Ω
G710050574	Adapter N(m) to BNC(f), DC to 1.5 GHz, 50 Ω
G710050575	Adapter N(f) to N(f), DC to 4 GHz, 50 Ω
G710050577	Adapter N(f) to DIN(f), DC to 4GHz, 50 Ω
G710050578	Adapter N(f) to DIN(m), DC to 4 GHz, 50 Ω
G710050579	Adapter DIN(f) to DIN(f), DC to 4 GHz, 50 Ω

**Optional E1/T1 Test Cables**

G710050317	RJ45 to Y Bantam Cable
G710050318	RJ45 to Y BNC Cable
G710050319	RJ45 to 4 Alligator Clips

**Miscellaneous**

G710050581	Attenuator 40 dB, 100W DC to 4 GHz (Unidirectional)
JD74050341	JD740 Soft Carrying Case
JD71050342	Hard carrying-case
JD71050343	JD7100 Back Pack carrying-case
JD74050343	JD740 Backpack Carrying Case
G710550324	External battery charger
JD7105B362	JD7105B User's Manual – Printed Version
JD745A362	JD745A User's Manual – Printed Version

**Test & Measurement Regional Sales**

<b>NORTH AMERICA</b> TEL: 1 866 228 3762 FAX: +1 301 353 9216	<b>LATIN AMERICA</b> TEL: +1 954 688-5660 FAX: +1 954 3454668	<b>ASIA PACIFIC</b> TEL:+852 2892 0990 FAX:+852 2892 0770	<b>EMEA</b> TEL:+49 7121 86 2222 FAX:+49 7121 86 1222	<a href="http://www.jdsu.com/test">www.jdsu.com/test</a>
---	---	---	---	--