

# Multiple Application Platform

## MAP-200



MAP-230B (top) and MAP-280 (bottom) mainframes

- Key Benefits**
- Available in three mainframe configurations
  - GPIB- and LXI-compliant (Ethernet)
  - Optional 10.4-inch touch-screen-display module with integrated keypad and scroll wheel
  - DVI port for external display
  - USB-device ports for external keyboard and mouse
  - Modules can be safely hot-swapped
  - Field-replaceable controller/power-supply module
  - Compatible with current MAP modules

### Applications

- Enables transceiver and transponder testing
- Permits comprehensive passive and active component, laser, and amplifier testing
- Facilitates 10 G and 40 G system and subsystem testing

### Compliance

- Optical source modules, when installed in the MAP Mainframe, meet the requirements of standard IEC 60825-1(2002) and comply with CFR 1040.10 except deviations per Laser Notice No. 50, July 2001 Key Feature Number 4
- CSA/UL/IEC 61010-1
- LXI Class C compliant

The JDSU Multiple Application Platform (MAP-200) is an optical test and measurement platform optimized for cost-effective development and manufacturing of optical transmission network elements. Today's rapidly changing optical market requires investment in productivity-enhancing technologies and tools, making the MAP-200 scalable test platform the right tool needed in even the most stringent environments.

Based on its previous generation, the MAP-200 builds on the differentiation of offering the broadest portfolio of modules in the densest and most configurable platform. The MAP-200 is optimized for test applications in lab and manufacturing environments ranging from insertion loss testing to dispersion penalty testing (see Table 1).

Passives	Lasers and Amplifiers	Optical Transport
Insertion Loss	Gain Flatness	Stress Receiver Compliance
Polarization Dependent Loss	Output Power	Jitter Testing
Return Loss	Transient Response	Sensitivity
	Spectral Width	Dispersion Penalty
	Side-Mode Suppression Ratio	SMSR
	Wavelength	Receiver Overload
	NF and OSNR	Eye Mask/Extinction Ratio
		OSNR Sensitivity

Table 1. List of MAP-200 applications by technology

### Multiple MAP-200 mainframe configurations

The MAP-200 mainframe comes in three configurations for optimal test set adaptability: a three-slot configuration and a 19-inch rack, eight-slot configuration oriented as either front- or rear-facing for optimal fiber routing. All three configurations are 3 RU high. The MAP-200 mainframes include hardware required for bench-top use, including rubber feet for optimal stability and vibration isolation. Furthermore, the MAP-200 saves costs because users can share modules within a mainframe.

### High-Performance MAP-200 Modules

The MAP-200 modules include 16 high-performance types including signal conditioning and switching, sources and amplification, and power meters.

**MAP power meters** increase absolute power measurement accuracy over a wide range of power and wavelengths with a broad combination of fiber types and connectivity options optimized for both datacom and telecom applications. High-speed data logging lets users make transient measurements.

**MAP amplifiers** meet the broadest optical-signal-amplification applications and available at various saturated output power, gain flattened or non-gain flattened, C-band, L-band, and with a low noise figure.

**MAP attenuators** provide the highest performance optical power control solution because they offer the lowest insertion loss, highest input-power capability, low polarization-dependent loss (PDL), high dynamic range, and ultra-flat attenuation over wavelength.

**MAP tunable filters** provide the lowest loss and narrowest bandwidth filter with the highest input-power capability in the industry.

**MAP switches** are the most configurable optical signal routing solutions in their class and are available in configurations including low-channel-count matrix (2x2) and single input to multiple outputs ranging from 2 to 50. In the 1x2 and 2x2 format, the modules have up to eight switches per single-slot module.

**MAP sources** are ideal for applications requiring a stable stimulus for parametric measurements and are available at key telecom wavelengths, with broad or narrow spectral bandwidth, or with tunable spectrum.

Other MAP-200 functions include a variable backreflector, a polarization controller, and utility modules.

## 3



Figure 1. Keypad/display module

### Elaborate local interface and friendly GUI

The graphical user interface (GUI) and local control of the MAP-200 mainframes work with standard universal serial bus (USB) keyboards, USB mice, and digital video interface (DVI) monitors. For added convenience and flexibility, JDSU offers an optional purpose-built keypad/display module (MAP-200KD) for local control capabilities, as shown in Figure 1. The MAP-200KD features a scroll wheel, seven soft keys, five navigation buttons, and seven pre-assigned buttons for use in navigating the GUI. Touch capability and user-friendly controls come standard for operation at the touch of a finger or with the supplied stylus. Located at the back of the MAP-200KD module is an industry-standard mounting port compatible with commercially available display mounts or the purpose-built MAP-200 keypad display 19-inch rack-mount kit (MAP-200A09). Alternatively, users can access the GUI using a PC via a virtual network connection (VNC) client.

As Figure 2a shows, the MAP-230 mainframe can be used with the MAP-200KD module mounted on top of it. The pop-out feet on the mainframe let users position it in a front-facing manner for optimal viewing and interaction.



Figure 2a . Mounting the MAP-200KD on the MAP-230 is the optimal configuration for applications where users frequently require GUI access.



Figure 2b. Configuring the MAP-200KD next to the MAP-280 is optimal for applications where users require access to the device under test, the MAP-200 modules, and the GUI.

### Extensive input/output interfaces

The MAP-200 is a USB-, general-purpose interface bus (GPIB)-, and Ethernet-enabled device that supports the latest test equipment interface standard, LXI, which is the Ethernet-based successor to GPIB. The LXI standard defines devices using open-standard for system inter-device communication.

All mainframe configurations include:

- GPIB, Ethernet, and USB device ports for remote communication
- 4 USB host ports for installing peripheral devices, including USB drives, a mouse, and a keyboard
- LXI-compliant trigger bus connections
- Ethernet reset button
- Laser interlock key in the front and a remote interlock connector in the rear
- LXI-compliant light-emitting diodes (LEDs) on the front panel
- DVI connector for an external monitor.

### Standard compliant automation drivers

MAP-200 has intuitive, optimized interchangeable virtual instrument (IVI) drivers for ease of use with popular application-development environments, such as LabVIEW, Visual C++, Visual Basic, and LabWindows™, provide full control of the modules and drop-in instrument programming capabilities. These capabilities let test programmers focus on test-level functions and sequences rather than the details required to communicate with the specific modules in the MAP system. The IVI drivers provide a simulation mode that lets automation developers capture system configurations so they can perform most of their development off line, freeing hardware for other purposes. These features make test automation development and debugging fast and easy.

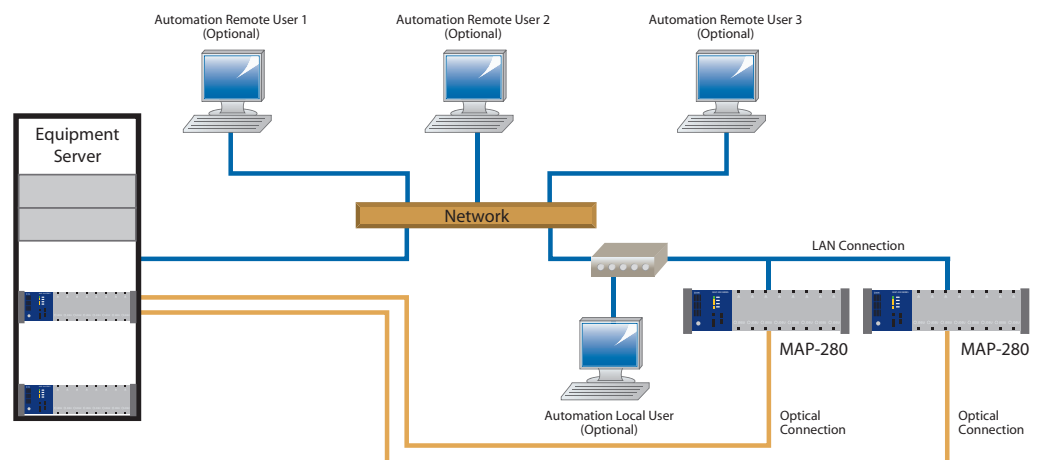

Figure 3. MAP implementation within a shared-resource environment

5

Specifications

Parameter	MAP-230	MAP-280	MAP-280R
Capacity	3 modules	8 modules	8 modules
Controller			
CPU		Power PC architecture	
Operating System		Linux	
Internal Storage		200 MB user flash storage	
Interfaces			
Remote interface		USB, GPIB, Ethernet 10/100/1000Base-T	
USB device compability		Mouse, keyboard, memory stick	
Display External		MAP-200KD (optional) or standard DVI monitor	
Ports			
USB host ports		2 rear and 2 front	
USB device ports		1 front	
LAN		1 rear	
GPIB		1 rear	
DVI video		1 rear	
LXI triggers		25-pin Micro-D connectors	
Automation			
Driver type		IVI-compliant	
Driver compatibility		LabVIEW, LabWindows, Visual C++, Visual Basic	
Accessibility		Multi-user sharing support	
Electrical and Safety			
Power <sup>1</sup>		100 to 200 V AC, 50/60 Hz, Auto-switching (field-replaceable as part of the power supply controller module)	
Power consumption		285 VA	
Local interlock		Key located in front	
Remote interlock		Terminals located in rear	
Mechanical and Environment <sup>2</sup>			
Rack-mount kit	Optional	Included	Included
Dimensions (W x H x D) <sup>3</sup>	29.2 x 14.9 x 42.0 cm (11.5 x 5.9 x 16.6 in)	49.6 x 14.9 x 42.0 cm (19.6 x 5.9 x 16.6 in)	49.6 x 14.9 x 42.0 cm (19.6 x 5.9 x 16.6 in)
Weight	5.9 kg (13 lb)	6.8 kg (15 lb)	6.8 kg (15 lb)
Operating temperature		0 to 50°C	
Storage temperature		-30 to 60°C	
Humidity		15-80% RH, 0 to 40°C non-condensing	

1. The MAP-200 system has been tested and certified to an altitude of 2,000 m.
2. Main supply voltage fluctuation must not exceed 10% of nominal supply voltage.
3. Dimensions include bench-top mounting hardware.

## 6

**Specifications Cont'd****MAP-200KD Display**

<b>Parameter</b>	<b>Specification</b>
Dimensions	10.4-inch color screen
Resolution	800 x 600 resolution
Power	Supplied from mainframe via MAP-200A01 Keypad/Display Cable Harness Kit
Weight	1.8 kg (4 lb)

## 7

**Ordering information**

For more information on this or other products and their availability, please contact your local JDSU account manager or JDSU directly at 1-800-498-JDSU (5378) in North America and +800-5378-JDSU worldwide or via e-mail at [customer.service@jdsu.com](mailto:customer.service@jdsu.com).

<b>Product Code</b>	<b>Description</b>
<b>Mainframes (Required)</b>	
MAP-280	MAP-200 8-slot mainframe
MAP-280R	MAP-200 8-slot mainframe factory-reversed configuration
MAP-230B	MAP-200 3-slot mainframe
<b>Power Cords (Required)</b>	
CORD-AU	Australia/China power cord
CORD-EU	European power cord
CORD-JP	Japan power cord
CORD-UK	United Kingdom power cord
CORD-US	United States power cord
<b>Accessories (Optional)</b>	
MAP-200BKD	MAP-200 stand-alone keypad/display module
MAP-200A01	MAP-200BKD keypad/display cable harness kit
MAP-200A03	MAP-200 8-slot mainframe 19-inch rack-mount kit
MAP-200A013	MAP-200 adaptor kit for single width MAP modules (requires one kit per device)
MAP-200A013D	MAP-200 adaptor kit for double width MAP modules (requires one kit per device)
MAP-200B09	MAP-200BKD keypad/display module rack-mount kit
MAP-200A10	MAP-200 3-slot mainframe 19-inch rack-mount kit
<b>Replacement/Spare Parts (Optional)</b>	
MAP-200A02	MAP-200 controller for MAP-280 and MAP-230B
MAP-200A02R	MAP-200 controller for MAP-280R
MAP-200A04	MAP-200 safety interlock key
MAP-200A06	MAP-200 blanking plates (kit of 3)
MAP-200A07	MAP-200 stylus
MAP-200A08	MAP-200 3-slot mainframe flip-up feet
MAP-200A11	MAP-200 detachable side panels for bench-top use
MAP-200A12	MAP-200 handles for detachable side panels

Visual Basic and LabWindows are registered trademarks of Microsoft Corporation.  
 LabVIEW is a registered trademark of National Instruments Corporation.  
 UL is a registered trademark of Underwriters Laboratories Inc.

**Test & Measurement Regional Sales**

<b>NORTH AMERICA</b> TOLL FREE: 1 855 ASK-JDSU 1 855 275-5378	<b>LATIN AMERICA</b> TEL: +1 954 688 5660 FAX: +1 954 345 4668	<b>ASIA PACIFIC</b> TEL: +852 2892 0990 FAX: +852 2892 0770	<b>EMEA</b> TEL: +49 7121 86 2222 FAX: +49 7121 86 1222	<a href="http://www.jdsu.com/test">www.jdsu.com/test</a>
---	--	---	---	--