

WaveReady™

100 GHz Dense Wavelength Division Multiplexing Optical Add/Drop Module



Key Features

- MUX/DEMUX of one, four, or eight ITU 100 GHz spaced channels onto a fiber pair
- Add/drop up to eight channels at remote sites
- Upgradeable to 32 channels per fiber
- Low pass-through insertion loss for C-band channels
- Fits into standard LGX™-mounting solutions
- Thermally stable passive optics require no power

Applications

- Improves capacity exhaust in fiber-constrained situations
- Conserves or reclaims fiber with DWDM
- Supports point-to-point multichannel
- Supports linear (bus) add/drop and hub-and-spoke ring architectures

Compliances

- Telcordia GR-1221
- RoHS compliant (exemptions 7b, 8a)

The JDSU WaveReady 100 GHz Optical Add/Drop Modules (OADM) comprise a family of flexible, low-cost solutions to enable capacity expansion of existing fiber. Through use of dense wavelength division multiplexing (DWDM) technology, a single optical fiber can carry up to 32 discrete optical channels.

The 100 GHz DWDM OADM is configurable as both an OADM and a terminal multiplexer and demultiplexer (MUX/DEMUX) to support a broad range of architectures ranging from scalable point-to-point links to four-fiber protected rings. Innovative band upgrade ports allow for in-service pay-as-you-grow capacity scaling in multiples of one, four, or eight channels, allowing for lowest first-day cost without limiting growth. Market standard LGX packaging is readily deployed in existing LGX-compatible frames or can be adapted into the WaveReady line of shelves.

The 100 GHz OADM is designed to operate with both the WaveReady line of transponder and optical regenerator solutions and ITU transponder cards of widely available transmission equipment.

2

Functional Diagrams

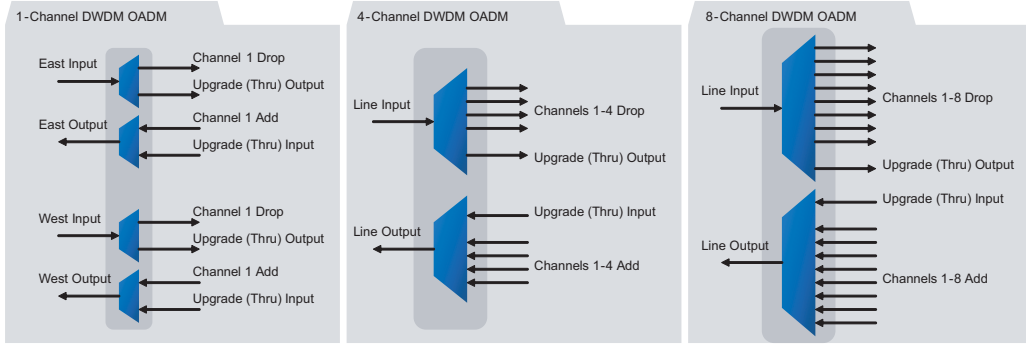

Sample Configurations

Point-to-Point DWDM



Protected Linear (Bus) Network

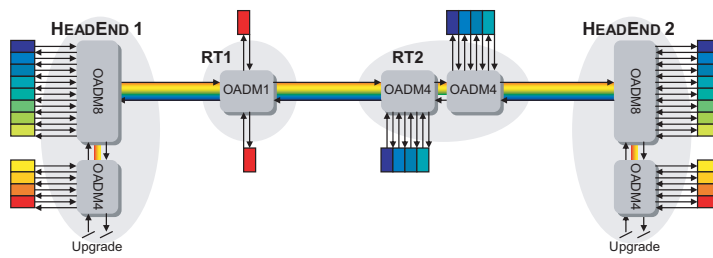

Protected Ring (Hub and Spoke)

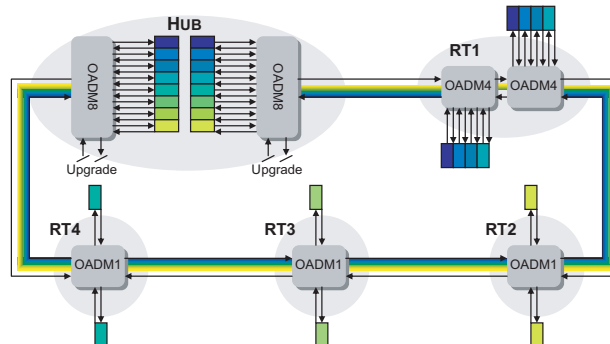

3

Specifications

Parameter ¹	1-Channel ²	4-Channel	8-Channel
Network Optical			
Mux/add insertion loss (Maximum)	1.4 dB	3.7 dB	4.0 dB
(Typical)	1.0 dB	2.6 dB	3.2 dB
Demux/drop insertion loss (Maximum)	1.4 dB	3.7 dB	4.0 dB
(Typical)	1.0 dB	2.6 dB	3.2 dB
Upgrade path insertion loss (Maximum)	0.9 dB	0.9 dB	1.2 dB
Optical pass-through insertion loss (Maximum)	1.8 dB	1.8 dB	2.4 dB
Channel passband (Minimum)	±0.1 nm	±0.1 nm	±0.1 nm
Channel flatness (Minimum)	0.5 dB	0.5 dB	0.5 dB
Channel loss uniformity	—	1 dB	1 dB
Isolation			
Adjacent ITU 100 GHz channel (Minimum)	25 dB	25 dB	25 dB
Non-adjacent ITU 100 GHz channel (Minimum)	50 dB	50 dB	50 dB
Through channel add/drop (Minimum)	30 dB	30 dB	30 dB
Optical return loss (Minimum)	40 dB	40 dB	40 dB
Input optical power—Sum of all ports (Maximum)	1 W	1 W	1 W
Polarization dependent loss (PDL) (Maximum)	0.2 dB	0.2 dB	0.2 dB
Polarization mode dispersion (PMD) (Maximum)	0.2 ps	0.2 ps	0.2 ps
Physical			
Size (H x W x L)	129.5 x 28.4 x 160.3 mm (5.10 x 1.12 x 6.31 in) single-slot LGX	129.5 x 28.4 x 160.3 mm (5.10 x 1.12 x 6.31 in) single-slot LGX	129.5 x 57.7 x 160.3 mm (5.10 x 2.27 x 6.31 in) double-slot LGX
Optical connector type, all ports	Duplex LC/PC	Duplex LC/PC	Duplex LC/PC
Weight (approximate)	0.45 kg (1 lb)	0.45 kg (1 lb)	0.91 kg (2 lb)
Environmental			
Operating ambient temperature	−5°C	—	70°C
Storage temperature	−40°C	—	85°C
Relative humidity (non-condensing)	5%	—	85%

¹All specifications are guaranteed over the life, operating temperatures, wavelength range, and input voltage specified.

²One-channel DWDM OADM provides add/drop functionality for two fiber pairs. Optical specifications for east and west interfaces are identical.

Ordering Information

For more information on this or other products and their availability, please contact your local JDSU account manager or JDSU directly at 1-800-498-JDSU (5378) in North America, +1 800-5378-JDSU worldwide or via e-mail at sales@jdsu.com.

Sample: MDX-04MD1001B

MDX-

Code	Channels
01AD	1
04MD	4
08MD	8

10 **B**

Channel Plan Codes

01AD	04MD	08MD	ITU Number	Frequency (THz)	Wavelength (nm)
61	—	—	61	196.10	1528.77
60	01	0A	60	196.00	1529.55
59	01	0A	59	195.90	1530.33
58	01	0A	58	195.80	1531.12
57	01	0A	57	195.70	1531.9
56	—	—	56	195.60	1532.68
55	02	0A	55	195.50	1533.47
54	02	0A	54	195.40	1534.25
53	02	0A	53	195.30	1535.04
52	02	0A	52	195.20	1535.82
51	—	—	51	195.10	1536.61
50	03	0B	50	195.00	1537.4
49	03	0B	49	194.90	1538.19
48	03	0B	48	194.80	1538.98
47	03	0B	47	194.70	1539.77
46	—	—	46	194.60	1540.56
45	04	0B	45	194.50	1541.35
44	04	0B	44	194.40	1542.14
43	04	0B	43	194.30	1542.94
42	04	0B	42	194.20	1543.73
41	—	—	41	194.10	1544.53
40	—	—	40	194.00	1545.32
39	—	—	39	193.90	1546.12
38	05	0C	38	193.80	1546.92
37	05	0C	37	193.70	1547.72
36	05	0C	36	193.60	1548.51
35	05	0C	35	193.50	1549.32
34	—	—	34	193.40	1550.12
33	06	0C	33	193.30	1550.92
32	06	0C	32	193.20	1551.72
31	06	0C	31	193.10	1552.52
30	06	0C	30	193.00	1553.33
29	—	—	29	192.90	1554.13
28	07	0D	28	192.80	1554.94
27	07	0D	27	192.70	1555.75
26	07	0D	26	192.60	1556.55
25	07	0D	25	192.50	1557.36
24	—	—	24	192.40	1558.17
23	08	0D	23	192.30	1558.98
22	08	0D	22	192.20	1559.79
21	08	0D	21	192.10	1560.61
20	08	0D	20	192.00	1561.42
19	—	—	19	191.90	1562.23
18	—	—	18	191.80	1563.05

Note: Contact your JDSU representative for required ITU wavelengths in the range of 1563.86 to 1527.99 nm.