

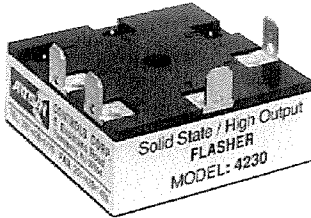

Solid State Timers and Controllers

4230

DC Flasher



Unlike most solid state devices that switch the low or ground side of the DC operating voltage, the model 4230 switches the high side of the DC operating voltage to an external load circuit when switched "ON." The flash rate can be specified over a wide range from 1 flash per minute to 10,000 flashes per minute. The duty cycle of the flashing rate is 50%. The model 4230 also provides a low current starting input circuit which assures that the high current output does not flow through the control switch. Load currents to 5 amperes may be driven with the output of the model 4230. The model 4230 is available only in a fixed flash rate version.

Mechanical & Wiring

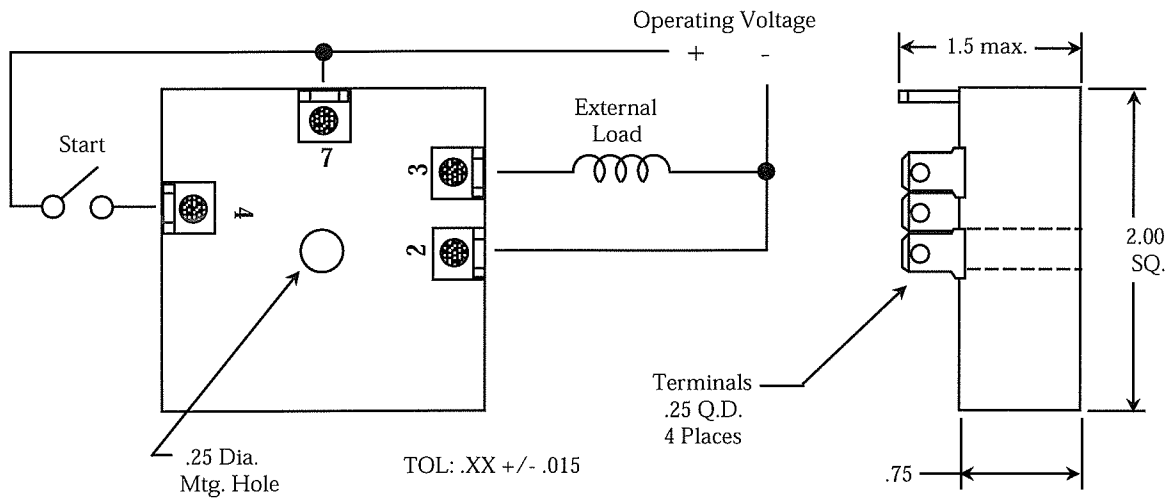

Timing Diagram

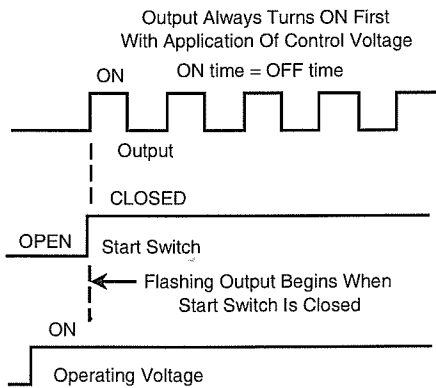

How To Find The Flash Rate

The timing diagram shown below is for an application that requires the load circuit to be ON for 60 milliseconds and OFF for 60 milliseconds. (Remember - the ON and OFF times will essentially be equal due to the 50% duty cycle specification inherent in the model 4230)

The voltage across the load circuit would look something this:

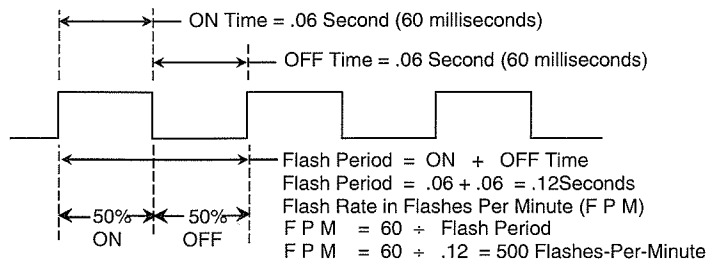



Solid State Timers and Controllers

Specifications

- Voltage:** 12V DC, 24V DC.
- Voltage Tolerances:** $\pm 20\%$.
- Timing Mode:** Flasher.
- Fixed Flash Rate:** Factory fixed at any rate from 1 to 10,000 flashes-per-minute (FPM)
- Flash Rate Duty Cycle:** Approximately 50%.
- Tolerances On Fixed Timing:** 10%.
- Flash Rate Variation:** Less than 4% over full temperature and voltage range.
- Repeatability Of Flashing Period:** $\pm 1\%$ at stabilized operating voltage temperature.
- Recycle Time:** Operating voltage must be removed for a minimum of 10 milliseconds to assure that the flasher and output circuits are reset.
- Start Switch Characteristics:** Less than 15mA at both 12V and 24V DC. load current does not pass through start switch. Flashing period begins on closure of start switch and terminates when start switch is opened.
- Output Rating:** 2mA to 5A inductive with inrush current to 50A for 100 milliseconds.
- Output Switch Characteristics:** 1 volt drop maximum across output switch when ON and load current is 10A, 1mA leakage when OFF.
- Transient Protection:** Output Switch protected by silicon transient suppressors responding to transients within 1×10^{-12} seconds to a peak pulse power dissipation of 1500 watts, with transient surge currents to 200 amperes for durations up to 1/120 second at 25° C. Maximum transient voltage protection is 6000 volts as delivered through a source resistance of 30 ohms with a maximum duration of 8.3ms.
- Dielectric:** 1500V rms all terminals to case.
- Operating Temperature:** 0°C to +70°C.
- Construction:** Encapsulated module with .25 quick connect wiring terminals.
- Data Sheet Revision Date:** May 18, 1995

Ordering Information All Models

| Part Number | Operating Voltage | Flash Rate |
|-------------|-------------------|-------------------------------|
| 4230 - 1 | 12V DC | Specify In Flashes Per Minute |
| 4230 - 2 | 24V DC | |

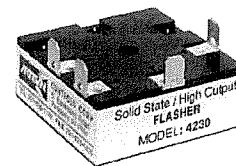

Examples Of Part Numbers

- 4230 - 1 - 90 Is a model 4230 with 12V DC operating voltage, with a fixed FPM (Flashes Per Minute) of 90.
Voltage to the load circuit is ON for 333 milliseconds, and OFF for 333 milliseconds.
- 4230 - 2 - 500 Is a model 4230 with 24V DC operating voltage, with a fixed FPM (Flashes Per Minute) of 500.
Voltage to the load circuit is ON for 60 milliseconds, and OFF for 60 milliseconds.
- 4230 - 2 - 5000 Is a model 4230 with 24V DC operating voltage, with a fixed FPM (Flashes Per Minute) of 5,000.
Voltage to the load circuit is ON for 6 milliseconds, and OFF for 6 milliseconds.

