

# RUGGED GALAXY™ SERIES PURE-SINEWAVE DC-AC INVERTERS

Input: 62-84 VDC

Output: 120V or 220V 1Ø

50, 60, or 400 Hz

Power: 120 VA - 35+ KVA



## APPLICATIONS

Utilizing field proven technology, this family of rugged pure sinewave DC-AC Inverters is suitable for harsh environments and can be customized for unique applications including:

- Shelters
- Rail
- Tactical Systems
- Ground support
- MIL-STD-810
- Utility Applications
- Mobile Systems
- MIL-STD-167
- MIL-STD-461



**NOVA ELECTRIC**

[www.novaelectric.com](http://www.novaelectric.com)

[novasales@theallpower.com](mailto:novasales@theallpower.com)



A Leader in DC-AC Inverter Technology since 1966 - 120VA to 35+KVA

MADE IN USA

# RUGGED PURE SINEWAVE DC-AC INVERTER

CAN MEET MIL-STD-810, MIL-STD-1399, MIL-S-901, MIL-STD-704, & MIL-STD-461 OPTIONALLY

## APPLICATIONS

The transformer isolated Galaxy Series Inverters are extremely rugged by design, and feature an optional advanced Internal Suppression Filter Network (ISFN) to suppress the significant transients usually associated with rail and military applications. The units are also extremely reliable, designed to provide many years of service in harsh shock, vibration, humidity, and EMI environments.

### HIGH-RELIABILITY

MTBF: 100,000 Hours  
MTBR: 30 Minutes (assuming qualified tech)

### STANDARD INDICATORS

- Output Volt & Amp Meters (GS/GH Models)
- Input Power On Lamp (GS/GH Models)

## SPECIFICATIONS

### ELECTRICAL

Input: 62 - 84VDC  
Output: specify 120 or 220VAC 1Ø  
**(Three-Phase Output Optional)**  
Frequency: Specify 50, 60, or 400Hz  
Voltage Regulation:  $\pm 2\%$  NL to FL  
Frequency Regulation:  $\pm 0.5\%$  NL to FL  
Harmonic Distortion: 5% THD  
Power Factor: 0.7 lead to 0.7 lag  
Efficiency at full load: 75-88% typical  
Overload: 125% for 5 minutes

### PROTECTIVE FEATURES

Current Limit, Short Circuit Protection, Thermal Protection, Semiconductor Protection, and (Optional) ISFN

### ENVIRONMENTAL

Operating Temp.:  $-20^{\circ}$  to  $+50^{\circ}\text{C}$   
Storage Temp. Range:  $-40^{\circ}$  to  $+71^{\circ}\text{C}$   
Humidity: to 95% non-condensing  
Elevation: 15,000 Ft. (4,572m) operating;  
40,000 ft. (12,192m) non-operating  
Shock: 20g for 11mS half sinewave  
Audible Noise: Less than 55 dbA at 5 ft.

### OPTIONS

- Ruggedization
- Chassis Slides (GS Models 1-5KVA)
- NEMA Cabinet Enclosures
- Additional Meters
- Input Transient Filter (ISFN)
- Transfer Switch

## MODEL SELECTION

MODELS	OUTPUT POWER	WEIGHT (LBS)	DIMENSIONS H x W x D (Inches)
GS1K60-72	1 KVA	87	5.25 x 19.00 x 22.00
GS1.5K60-72	1.5 KVA	105	5.25 x 19.00 x 22.00
GS2K60-72	2 KVA	120	5.25 x 19.00 x 22.00
GS2.5K60-72	2.5 KVA	125	8.75 x 19.00 x 23.00
GS3K60-72	3 KVA	130	8.75 x 19.00 x 23.00
GS5K60-72	5 KVA	140	8.75 x 19.00 x 23.00

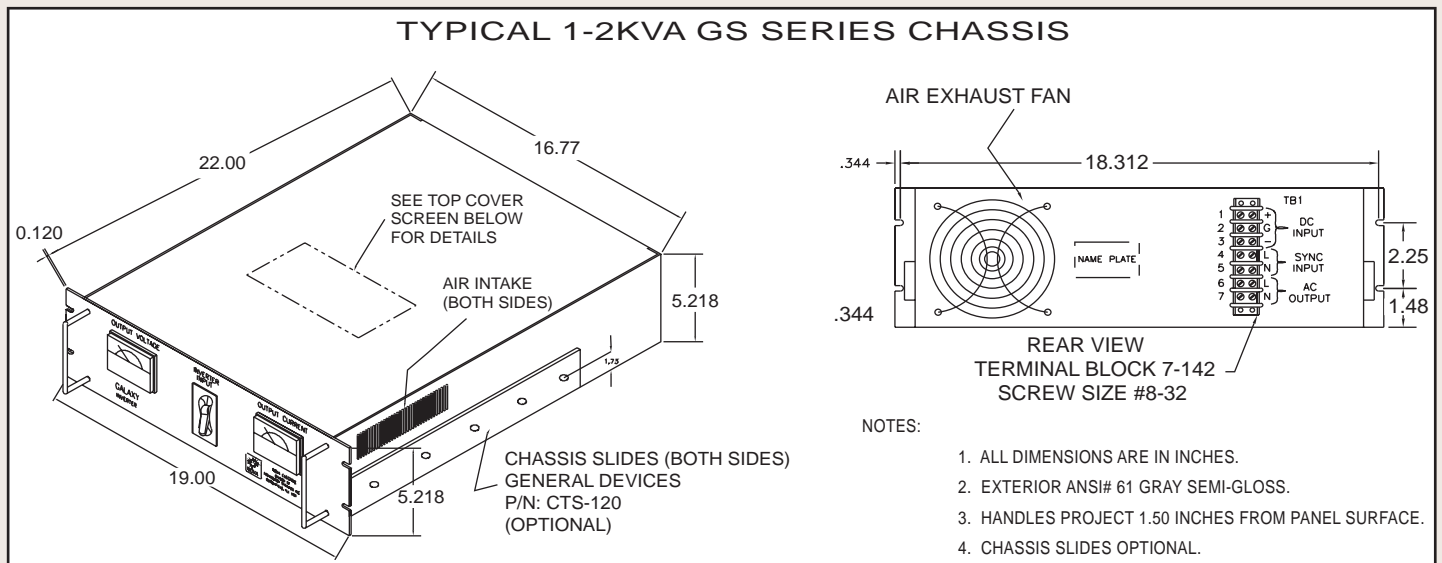

WEB : [www.novaelectric.com](http://www.novaelectric.com)

E-Mail : [novasales@theallpower.com](mailto:novasales@theallpower.com)

PHONE : (201) 385-0500 FAX : (201) 385-0702



**NOVA ELECTRIC**

A Division of

TECHNOLOGY DYNAMICS, INC.

100 School St., Bergenfield NJ 07621



ISO 9001