

Mechanical Counters, Ratchet Type Series M39

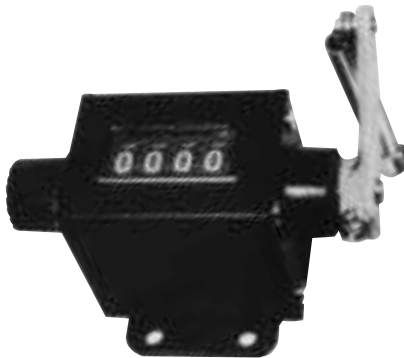

*M39 Series
3-digit*



*M39 Series
4-digit*

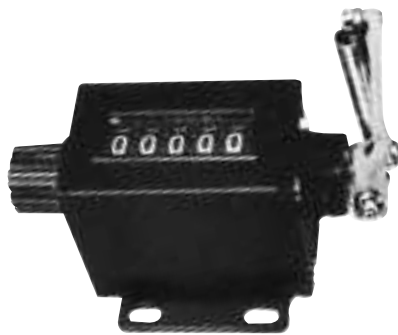

*M39 Series
5-digit*

Level is returned to its original position by means of internal spring. Compact and rugged, this counter is ideally suited for installation on machine tools, automatic vending machines, and industrial applications where only limited space is available. There will be little or no wear of the bearing. Offered in a black case in 5-digit, 4-digit, and 3-digit types. Units are also available in right or left hand shafts and top coming or top going direction.

Specifications

Display Reading:	99999 Counts
Figures:	.157" (4mm) H x .098" (2.5mm) W white on black
Reset:	Knob reset from left or right
Service Life:	Approx. 25 million counts
Counter Speed:	400 C.P.M.
Type Of Drive:	Ratchet with stop
Max Torque:	150 g per cm
Mounting:	Base mount
Required Input:	40°-45° for one count

Features

- Compact and Rugged Design For Long Life
- Easy To Mount and Manual Reset
- Maximum Speed 400 Counts Per Minute
- Materials Used Are Corrosion Resistant
- No Lubrication Required
- Non-Resettable Types Also Available
- Low Cost

3-DIGIT

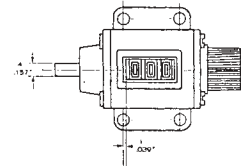
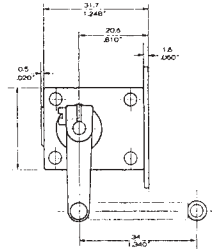
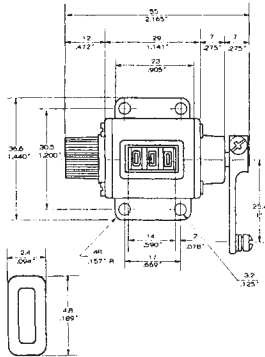

mm
inch

4-DIGIT

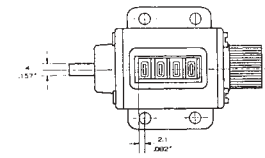
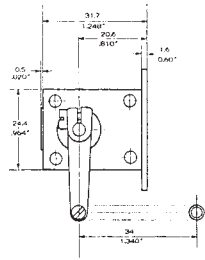
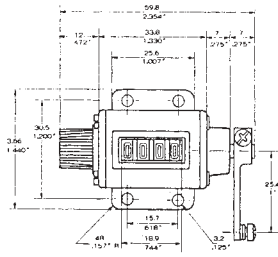

mm
inch

5-DIGIT

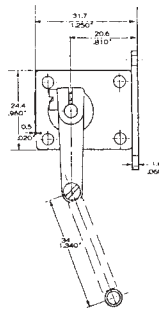
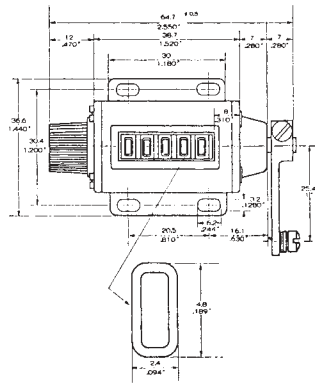

mm
inch

TOLERANCE $\pm 0.5\text{mm}$
 $\pm 0.020\text{"}$

NUMERALS	ROTATION	ROTATION	ROTATION	ROTATION
3	M39CA30B	M39CA30A	M39CA30C	M39CA30D
4	M39CA40B	M39CA40A	M39CA40C	M39CA40D
5	M39CA50B	M39CA50A	M39CA50C	M39CA50D

ENM Co.® is a registered trademark of the ENM Company