

375 WATT
EMERGENCY POWER



MODEL NO: _____
 TYPE: _____
 PROJECT: _____
 COMMENTS: _____

LOAD CAPABILITY

375 Watts

FIXTURE TYPES

Fluorescent
 Incandescent

DESCRIPTION

The IOTA IIS-375-I is a UL Listed stand-alone sine wave output inverter designed to provide power to designated emergency lighting fixtures. In a power loss situation, the IOTA IIS-375-I will supply **375W** of power from the onboard battery supply. The IOTA IIS-375-I works in conjunction with incandescent and fluorescent lamp and fixture types and will automatically run switched, normally-on, or normally-off designated emergency fixtures. The IIS-375-I is ideal for applications requiring an emergency source for lighting arrangements that utilize multiple lamp and fixture types. The IIS-375-I is available in a surface mount housing and comes with a three-year warranty and seven-year pro-rata battery warranty.

SPECIFICATIONS

Input Voltage (Dual) 120/277V, 60Hz
 Input Rating (bulk) 500 Watts
 Output Voltage (Dual) 120/277V, 60Hz
 Output Power 375 Watts (@ .9 leading to .9 lagging PF)
 Lamps Operated Fluorescent, Incandescent
 Transfer Time less than 50 milliseconds
 Emergency Operation 90 minutes
 Voltage Regulation (emergency) +/- 2% @ 15% to 110% load
 Frequency Regulation (emergency) +/- .5%
 Load Power Factor Range9 leading to .9 lagging
 Operating Temp 20° to 30° C
 Battery Valve Regulated Lead Acid (VRLA)
 Weight 114 lbs.
 Approval UL 924 Listed



DIMENSIONS

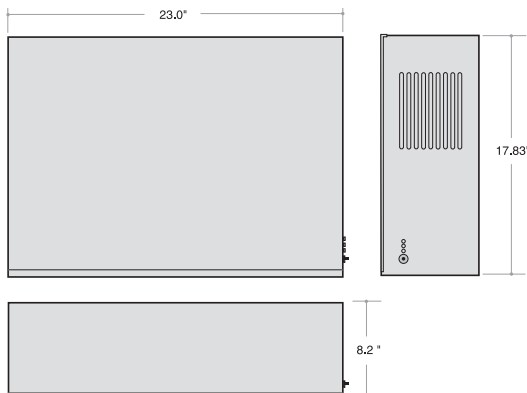

FEATURES

- Emergency lighting supplied from one convenient source
- Pure sine wave output
- Operates incandescent and fluorescent fixtures including fixtures with dimmable fluorescent ballasts
- Includes momentary contact test switch, yellow ready indicator, green inverter-on indicator, and red charging indicator
- Dual voltage 120/277 60Hz
- High efficiency pure sine wave inverter
- Variable-rate, temperature-compensated charger
- Valve Regulated Lead Acid (VRLA) battery provides long life and is maintenance free
- Line voltage allows for remote mounting of emergency fixtures at distances up to 1000 feet
- Output circuit breaker protection for easy reset
- Low Battery Voltage Disconnect
- Line Latch Protection
- Flying Leads for operating switched fixtures
- Meets or exceeds all National Electrical Code and Life Safety Code Emergency Lighting Requirements
- Durable 16-gauge steel housing design with white semi-gloss powder-coat paint finish
- 3/7 Pro-Rata Warranty

EMERGENCY INVERTERS



IIS-375-I

375W SURFACE MOUNT UNIT INVERTER SYSTEM

COMPONENTS

- High-efficiency modified sine wave inverter
- Variable-rate, temperature-compensated charger
- 12V oversized Valve Regulated Lead Acid (VRLA) battery

CONSTRUCTION

- 16-gauge steel housing

IIS-375-I SAMPLE SPECIFICATION

Emergency lighting shall be provided by inverter unit equipment designed to operate designated incandescent, fluorescent and LED fixtures on emergency power at their full nominal lumen rating during the full 90-minute emergency discharge cycle. System output will be rated at 375 watts for 90 minutes and provide an electronically fused output connection to the load. The system's voltage rating shall be field selectable 120 or 277 VAC input/output.

The inverter unit shall allow for connected emergency fixture(s) to be normally on, normally off, switched or dimmed without affecting lamp operation during a power failure. Upon utility power loss, the inverter unit shall deliver 100% of its full rated output regardless of the local switch or dimmer position, and will provide power to emergency fixtures at distances of up to 1000 feet.

The housing shall be designed for surface mount installation requirements and manufactured using 16-gauge steel with a white hammer semi-gloss scratch-resistant baked-on powder coat paint finish.

The unit's electronics shall include a self-contained inverter section with a fully automatic, thermal-compensating variable-rate battery charger, AC lockout feature, low battery voltage disconnect, DC overload, short circuit and brownout protection as standard. The unit shall utilize a sealed lead calcium battery with a 10-year design life. The inverter system shall be UL 924 Listed and labeled. The unit shall be covered under a 3-year warranty on the electronics and battery and a 7-year pro-rata warranty on the battery. It shall meet or exceed the requirements of UL 924, NFPA 101 Life Safety Code, NFPA 70 National Electrical Code, OSHA and State and Local codes.

The inverter unit shall be IOTA model IIS-375-I.

TYPICAL WIRING

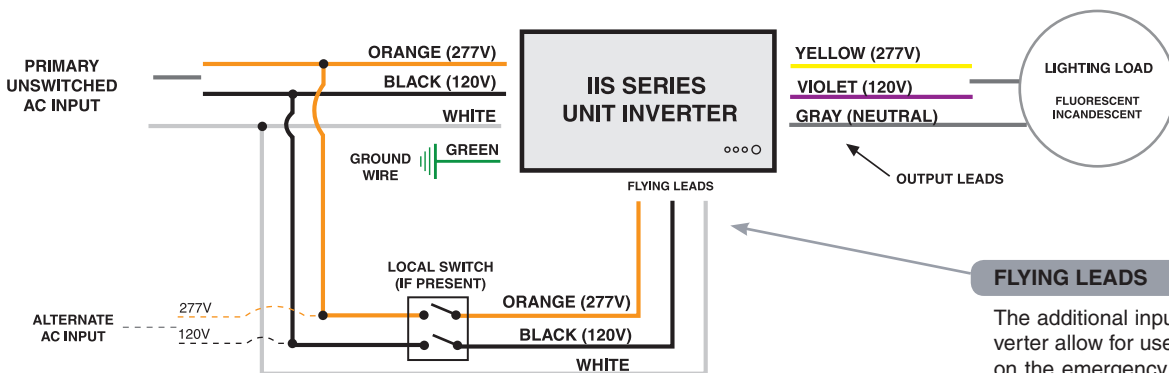

FLYING LEADS

The additional input leads of the IIS inverter allow for use of switched fixtures on the emergency circuit. When a loss of AC power occurs, the fixtures on the emergency circuit will be powered by the IIS Inverter supply, regardless of switch position.