

GRID CEILING MOUNTING SOLUTION



MODEL NO: _____
 TYPE: _____
 PROJECT: _____
 COMMENTS: _____

DESCRIPTION

The IOTA **IIS-125-CG** is a UL Listed stand-alone modified sine wave output inverter designed to provide power to designated emergency lighting fixtures. In a power loss situation, the IOTA **IIS-125-CG** will supply **125W** of power from the onboard battery supply. The IOTA **IIS-125-CG** works in conjunction with incandescent, LED, and fluorescent lamp and fixture types and will automatically run switched, normally-on, or normally-off designated emergency fixtures. The **IIS-125-CG** is ideal for applications requiring an emergency source for lighting arrangements that utilize multiple lamp and fixture types. The **IIS-125-CG** is designed for installation in the ceiling grid and comes with a three-year warranty and seven-year pro-rata battery warranty. The **IIS-125-CG** is not for use in air supply/air return ceilings.

SPECIFICATIONS

Input Voltage	(Dual) 120/277V, 60Hz
Input Rating (bulk)	150 Watts
Output Voltage	(Dual) 120/277V, 60Hz
Output Power	125 Watts (@ .9 leading to .9 lagging PF)
Lamps Operated	LED, Fluorescent, Incandescent
Transfer Time	less than 50 milliseconds
Emergency Operation	90 minutes
Voltage Regulation (emergency)	+/- 10%
Frequency Regulation (emergency)	+/- 3%
Load Power Factor Range9 leading to .9 lagging
Operating Temp	20° to 30° C
Battery	Valve Regulated Lead Acid (VRLA)
Weight	42.5 lbs.
Approval	UL 924 Listed



DIMENSIONS

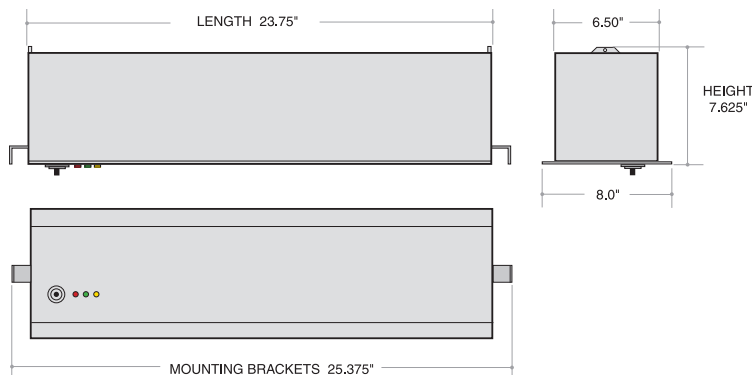

LOAD CAPABILITY

125 Watts

FIXTURE TYPES

- LED
- Fluorescent
- Incandescent

FEATURES

- Emergency lighting supplied from one convenient source
- Operates incandescent, LED, and fluorescent fixtures including fixtures with dimmable fluorescent ballasts
- Grid ceiling mounting design
- Includes momentary contact test switch, yellow ready indicator, green inverter-on indicator, and red charging indicator
- Dual voltage 120/277 60Hz
- Replaceable output fuse protection
- High efficiency modified sine wave inverter
- Variable-rate, temperature-compensated charger
- Valve Regulated Lead Acid (VRLA) battery provides long life and is maintenance free
- Line voltage allows for remote mounting of emergency fixtures at distances up to 1000 feet
- Low Battery Voltage Disconnect
- Line Latch Protection
- Flying Leads for operating switched fixtures
- Meets or exceeds all National Electrical Code and Life Safety Code Emergency Lighting Requirements
- Durable 18-gauge steel housing design with white semi-gloss powder-coat paint finish
- 3/7 Pro-Rata Warranty

EMERGENCY INVERTERS



IIS-125-CG

125W CEILING GRID UNIT INVERTER SYSTEM

COMPONENTS

- High-efficiency modified sine wave inverter
- Variable-rate, temperature-compensated charger
- 12V oversized Valve Regulated Lead Acid (VRLA) battery

CONSTRUCTION

- 18-gauge steel housing

IIS-125-CG SAMPLE SPECIFICATION

Emergency lighting shall be provided by inverter unit equipment designed to operate designated incandescent, fluorescent and LED fixtures on emergency power at their full nominal lumen rating during the full 90-minute emergency discharge cycle. System output will be rated at 125 watts for 90 minutes and provide fused output connections to the load. The system's voltage rating shall be field selectable 120 or 277 VAC input/output.

The inverter unit shall allow for connected emergency fixture(s) to be normally on, normally off, switched or dimmed without affecting lamp operation during a power failure. Upon utility power loss, the inverter unit shall deliver 100% of its rated output to the designated emergency fixtures regardless of the local switch or dimmer position, and will provide power to the emergency fixtures at distances of up to 1000 feet.

The housing shall be designed for ceiling grid installation requirements excluding air supply/air return ceiling applications, and shall be manufactured using 18-gauge steel with a white hammer semi-gloss scratch-resistant baked-on powder coat paint finish.

The unit's electronics shall include a self-contained inverter section with a fully automatic, thermal-compensating variable-rate battery charger, AC lockout feature, low battery voltage disconnect, DC overload, short circuit and brownout protection as standard. The unit shall utilize a sealed lead calcium battery with a 10-year design life. The inverter system shall be UL 924 Listed and labeled. The unit shall be covered under a 3-year warranty on the electronics and battery and a 7-year pro-rata warranty on the battery. It shall meet or exceed the requirements of UL 924, NFPA 101 Life Safety Code, NFPA 70 National Electrical Code, OSHA and State and Local codes.

The inverter unit shall be IOTA Engineering model IIS-125-CG.

TYPICAL WIRING

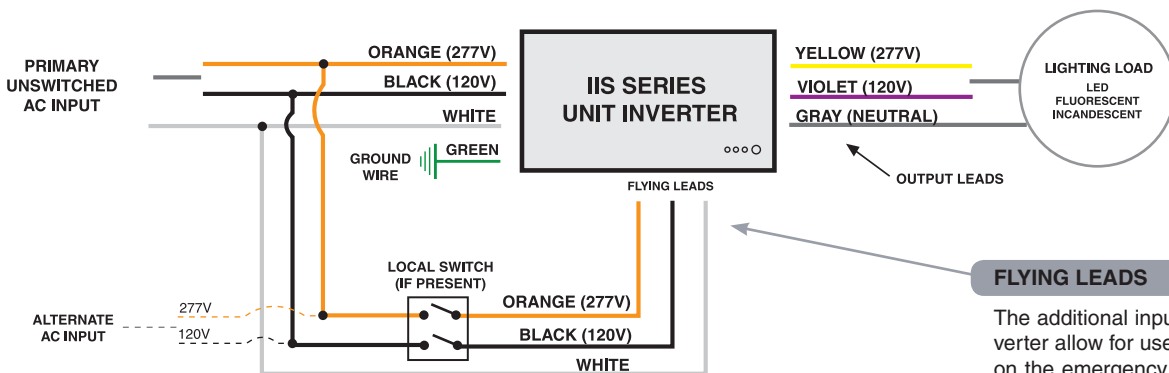

FLYING LEADS

The additional input leads of the IIS inverter allow for use of switched fixtures on the emergency circuit. When a loss of AC power occurs, the fixtures on the emergency circuit will be powered by the IIS Inverter supply, regardless of switch position.