



MODEL NO: _____
 TYPE: _____
 PROJECT: _____
 COMMENTS: _____

LED OPERATION:

20 Watt LED Load
 @ 18 - 26 VDC nominal

OUTPUT:

Up to 20W

DESCRIPTION

The **ILB-1826 750mA** from IOTA Engineering is a UL Recognized LED emergency battery pack that allows the same LED fixture to be used for both normal and emergency operation. In the event of a power failure, the **ILB-1826 750mA** switches to the emergency mode and operates the existing fixture for **90 minutes**. The unit includes two 7-cell long life high temperature Ni-Cad battery packs, and a single can containing a charger and converter circuit for wiring to the fixture and test accessories. The **ILB-1826 750mA** is for use with an LED load up to **20W** at a rated current of **750mA**.

SPECIFICATIONS

Input Voltage	(Dual) 120/277 VAC, 60Hz
Input Rating	5.5 Watts
Output Voltage	18V - 26V
Output Current	750 mA (constant)
Output Power	Up to 20W max.
Emergency Operation	90 minutes
Operating Temp	0° to 50° C
Battery	Nickel-Cadmium 24 Hour Recharge 7-10 Year Life Expectancy
Weight	4.0 lbs.
UL Conditions of Acceptability	Must be factory wired Battery temperature must not exceed 50° C

FEATURES

- UL Recognized Component
- Long life high temperature recyclable Ni-Cad batteries
- Galvanized steel case
- Includes test switch and charge indicator accessory kit
- Suitable for use in damp locations
- For use with switched or unswitched fixtures
- **5-Year Warranty.** See Warranty Page for details.
- Meets or exceeds all National Electrical Code and Life Safety Code Emergency Lighting Requirements



DIMENSIONS

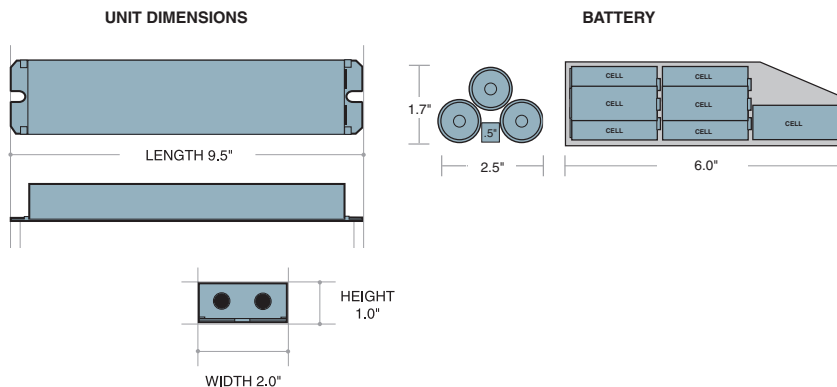

ILB-1826 750mA

LED EMERGENCY BATTERY PACK

OPTIONS

TEST KIT CONFIGURATION

- TBTS
- TWO-PIECE TEST SWITCH AND CHARGE INDICATOR

BATTERY CONFIGURATIONS

- D - DUAL BATTERY PACKS (TWO 7-CELL)

ILB-1826 750mA SAMPLE SPECIFICATION

Emergency lighting shall be provided by using a standard LED fixture equipped with an **ILB-1826 750mA** LED emergency battery pack. The **ILB-1826 750mA** shall consist of (1) or (2) high temperature, maintenance-free nickel cadmium battery packs, and a 9.5" x 2.0" x 1.0" vandal-resistant galvanized steel case containing a charger board and an electronic circuit. The unit is designed for installation within the fixture or ballast compartment. A test switch and charge indicator accessory kit shall be included. The LED emergency battery pack shall operate an LED load of up to 20W at a rated current output of 750mA for a minimum of 90 minutes in the emergency mode. The **ILB-1826 750mA** shall have 5.5 watts of input power and a battery capacity of 24 watt hours. The **ILB-1826 750mA** is a UL Recognized Component and meets or exceeds all NEC and Life Safety Code Emergency Lighting Requirements. The **ILB-1826 750mA** is warranted for a full five (5) years from the date of purchase.

ILB-1826 750mA SAMPLE WIRING DIAGRAM

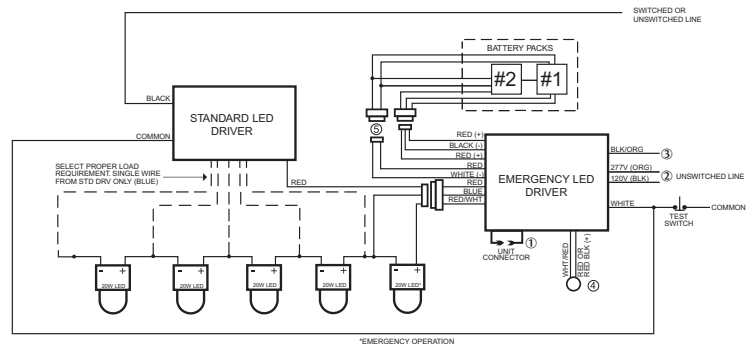

- *EMERGENCY OPERATION
- ① DO NOT MATE CONNECTOR UNTIL INSTALLATION IS COMPLETE AND AC POWER IS SUPPLIED.
 - ② SELECT PROPER VOLTAGE LEAD, CAP UNUSED LEAD.
 - ③ BLK/ORG LEAD FOR COLD-WEATHER UNIT ONLY. FOR COLD-WEATHER UNIT 120V INSTALLATION, CONNECT BLK/ORG TO BLK. FOR COLD-WEATHER UNIT 277V INSTALLATION, CAP BLK/ORG AND BLK SEPARATELY.
 - ④ TEST ACCESSORY LEADS-OBSERVE PROPER POLARITY WIRING.
 - ⑤ OPTIONAL CONNECTOR FOR COLD-WEATHER HEATING BLANKET ONLY FOR NON-COLD-WEATHER UNITS, LEAVE DISCONNECTED.