



MODEL NO: \_\_\_\_\_  
 TYPE: \_\_\_\_\_  
 PROJECT: \_\_\_\_\_  
 COMMENTS: \_\_\_\_\_

LED OPERATION: PATENT PENDING

5 Watt LED Load  
 @ 10-60 VDC nominal<sup>1</sup>

OUTPUT:  
 5 Watts (Constant)

### DESCRIPTION

The **ILB-CP05** from IOTA Engineering is a UL Classified LED emergency driver that allows the same LED fixture to be used for both normal and emergency operation. In the event of a power failure, the **ILB-CP05** switches to the emergency mode and operates the existing fixture for **90 minutes**. The unit contains a battery, charger, and converter circuit in a single can and is available in different mounting configurations for individual fixture requirements. The **ILB-CP05** will operate an LED array load at **5 watts** with **constant power** at a rated output voltage of **10V-60V**. The Constant Power design of the **ILB-CP05** maintains the output wattage to the LED array even as the system voltage diminishes.

### SPECIFICATIONS

Input Voltage .....	(Universal) 120-277VAC, 50/60Hz
Input Rating (120/277) .....	2.7 Watts (max)
Output Voltage <sup>1</sup> .....	10-60VDC Class 2 Compliant
Output Current .....	0.5A (@10VDC) - 0.08A (@60VDC)
Output Power .....	5 Watts (constant)
Emergency Operation .....	90 minutes
Operating Temp .....	0° to 55° C
Battery .....	High Temp Nickel-Cadmium 24 Hour Recharge 7-10 Year Life Expectancy
Weight .....	(-A, -R) 3.0 lbs. (-B, -TM) 2.5 lbs. (-J, -R-J) 2.75 lbs.
Approval .....	UL and CUL Classified as an LED emergency driver for field installation

<sup>1</sup>Max. output voltage in emergency mode is 58.5 VDC with a + tolerance of 1.5 volts



### DIMENSIONS

9.5" x 2.375" x 1.5" (mounting center 9.0")

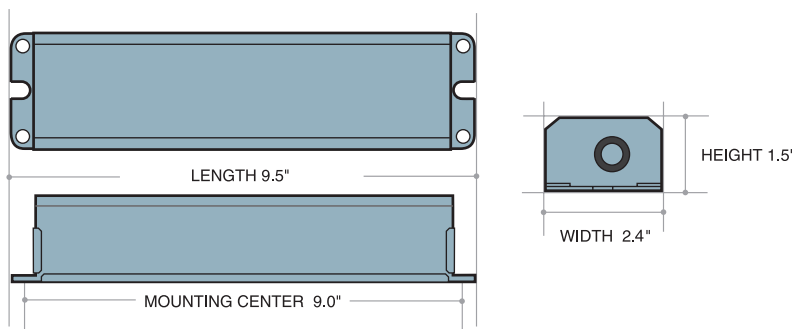

### PRODUCT ADVANTAGES

- **Classified for field installation**
- **Constant Power Design maintains illumination throughout the 90-minute runtime with no light degradation**
- **Two-wire universal AC input**
- **Self-sensing output voltage allows the CP Series to operate various product types, such as downlights, troffers, or strips, reducing product SKUs for emergency options.**

### FEATURES

- UL Classified for Field Installation
- UL 1310 Certified, Output Class 2 Compliant
- Six mounting configurations available
- Long life high temperature recyclable Ni-Cad battery
- Galvanized steel case
- Includes single-piece TBTS test switch and charge indicator accessory kit
- For use with switched or unswitched fixtures
- **5-Year Warranty.** See Warranty Page for details.
- Meets or exceeds all National Electrical Code and Life Safety Code Emergency Lighting Requirements
- Suitable for use in Damp Locations



# ILB-CP05

CONSTANT POWER LED EMERGENCY DRIVER

## TEST KIT CONFIGURATION

- TBTS

## MOUNTING CONFIGURATIONS

- -A (Dual Flex unit)

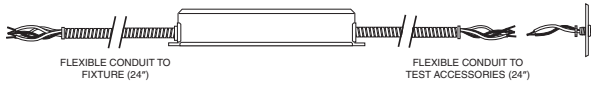

- -B (Integral Non-Flex unit)

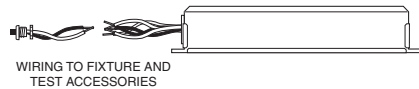

- -J (Single Flex Junction Box Mount unit)

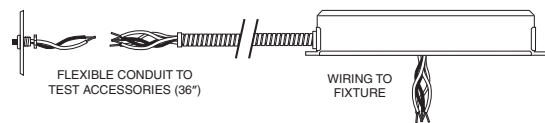

- -R (Dual Flex unit with Reflector-Mount TBTS switch)

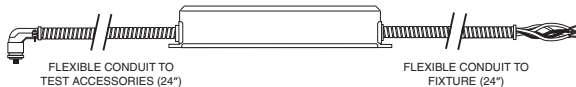

- -TM (Top-Mounting Non-Flex unit)



- -R-J (Single Flex with Reflector-Mount TBTS switch)

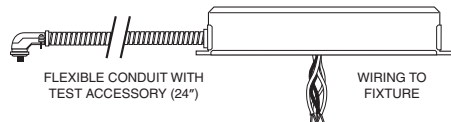

## ACCESSORIES

- TMK-80 Top Mount Cover

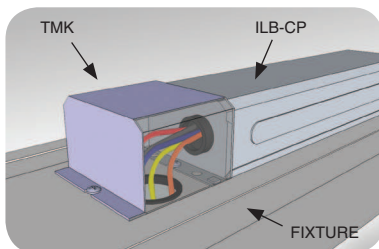

When top-mounting "B" configuration ILB-CP units, the TMK-80 is used to cover the exposed wiring that goes from the battery pack into the fixture.

- TBMK T-Grid Mounting Kit

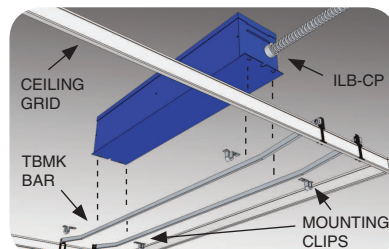

Use the TBMK mounting kit to remote mount flexed units within a grid ceiling. The ILB-CP is secured to the bars of the TBMK via mounting clips. The bars then mount to the T-bars of the ceiling grid. The flexible conduit of the ILB-CP connects to the fixture.

- RME1 Remote Mounting Enclosure

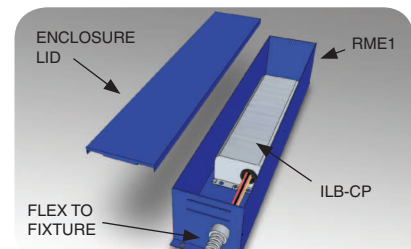

The RME1 enclosure accepts "B" configuration ILB-CP units for remote mounting. The ILB-CP is secured within the enclosure and wiring is routed through the 2 ft. of flexible conduit for connecting to the fixture. Can be used in conjunction with the TBMK for grid ceiling mounting.

## ILB-CP05 SAMPLE SPECIFICATION

Supply and install IOTA [Insert 5W model number] Constant Power emergency LED driver system as indicated on the plans. The emergency driver shall be designed for [Select "Internal" or "External"] mounting to the luminaire including a self-contained, high-temperature, sealed, maintenance-free nickel cadmium battery rated for a 10-year service life. The unit shall be provided complete with an illuminated push to test switch. The emergency driver system shall be UL class 2 certified in accordance with UL 1310 and shall be UL listed for use in damp locations with a temperature range of 0° to 55° C.

The AC input shall be a two-wire, universal voltage capable 120 thru 277 VAC, 50/60 Hz and be UL Classified to Category Control Number (CCN) FTBR, Emergency Lighting and Power Equipment, and FTBV, Emergency Light-Emitting-Diode Drivers for field installation. Maximum input power of the emergency driver shall be 2.7 watts.

The unit charger shall consist of a two-stage charging system which samples the battery in relation to its temperature, state of charge and input voltage fluctuations. The charger shall be current limited, temperature compensated, short-circuit protected with reverse polarity protection. A low voltage battery disconnect (LVD) circuit shall be provided and will disconnect the load and circuitry from the battery when it reaches approximately 80 to 85% of its nominal terminal voltage, preventing a non-recoverable, deep-discharge condition as well as equipment initialization failure when utility power is restored. The unit shall achieve a full recharge in 24-hours.

The emergency driver shall accommodate an LED load with a forward voltage requirement ranging from 10 to 60 VDC. The output voltage sensing shall be automatic and instantaneous with a resulting, inversely-proportional current to maintain constant power to the LED array with an output tolerance of +/- 3%. The unit shall supply the rated load for a minimum of 1 1/2 hours or to 87 1/2% of rated battery terminal voltage. The output power to the LED load during emergency operation shall be held constant 5 watts from minute one throughout the entire emergency run time resulting in no loss or degradation of the light source during emergency operation.

The unit shall be furnished with an electronic, AC-lockout circuit which will connect the battery when the AC circuit is activated, and an electronic brownout circuit which will enable a transfer to emergency operation when utility power dips below an acceptable level. Maximum remote mounting distance of the emergency driver shall be 50-feet.

## SPECIFICATION TOOLS FOR UL CLASSIFIED FIELD INSTALLATION



The **ILB-CP05** is UL Classified for Field Installation. Refer to the "CP Series Compatibility and Suitability of Use Guidelines" addendum for complete project installation requirements.

## IOTA ILB-CP PERFORMANCE CALCULATOR



Visit [www.iotaengineering.com/cptools](http://www.iotaengineering.com/cptools) to access our on-line CP performance calculator for assistance when determining lumen output and operating specifications for your unit, in addition to convenient links to other specification materials.