

TECHNICAL CHARACTERISTICS

MATERIAL
 INSULATOR: LCP
 FLAMABILITY RATING: UL94-V0
 COLOR: BLACK
 CONTACT MATERIAL: COPPER ALLOY
 CONTACT TYPE: STAMPED
 CONTACT PLATING: GOLD
 SHIELDING: STAINLESS STEEL NI PLATED
 QUALITY CLASS: 10000 MATING CYLCES

ENVIRONMENTAL
 OPERATING TEMPERATURE: -40°C UP TO +85°C
 COMPLIANCE: LEAD FREE AND ROHS

ELECTRICAL
 CURRENT RATING: 3.0A PIN1 & PIN 5
 1.0A OTHER PINS
 WORKING VOLTAGE: 30 VAC
 INSULATION RESISTANCE: >1000 MΩ
 WITHSTANDING VOLTAGE: 100 VAC/min
 CONTACT RESISTANCE: 30 mΩ max

SOLDERING
 JEDEC LEAD FREE REFLOW SOLDERING PROCESS

PACKAGING
 TAPE & REEL

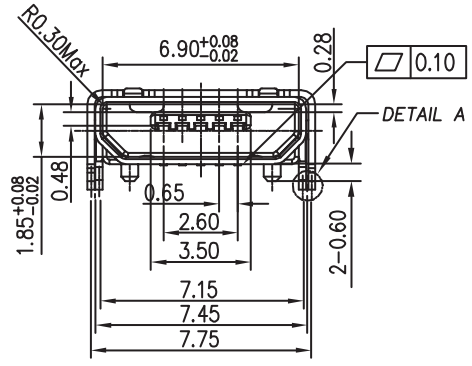
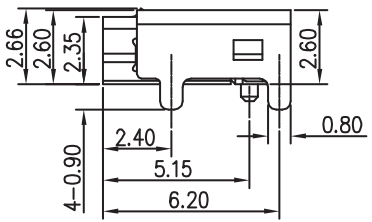

DETAIL A
 SCALE: 8:1

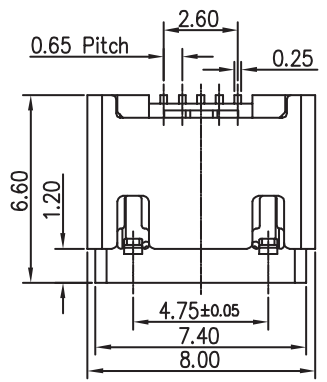

RoHS Compliant				PROJECTION: 	GENERAL TOLERANCE .X = +/- 0.3 .XX = +/- 0.20		DESCRIPTION: MICRO USB 2.0 TYPE B - HORIZONTAL - SMT	SIZE A4
G								
F								
E								
D								
C			APPROVAL: RJ	UNIT: MM	WERI PART NO: 629 105 150 521			
B				SCALE:				
A	25-AUG-14	PDF	AS	SHEET: 1/1				
REV	DATE	FILE	BY	DRAW: AS				

1

2

3

4

5

Cautions and Warnings:

This electronic component is designed and developed with the intention for use in general electronics equipments.

Before incorporating the components into any equipments in the field such as aerospace, aviation, nuclear control, submarine, transportation, (automotive control, train control, ship control), transportation signal, disaster prevention, medical, public information network etc. where higher safety and reliability are especially required or if there is possibility of direct damage or injury to human body, Würth Elektronik must be asked for a written approval.



In addition, even electronic component in general electronic equipments, when used in electrical circuits that require high safety, reliability functions or performance, the sufficient reliability evaluation-check for the safety must be performed before by the user before usage.

A

B

C

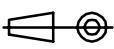
RoHS Compliant

G				PROJECTION: 	GENERAL TOLERANCE .X = +/- 0.2 .XX = +/- 0.15	 WÜRTH ELEKTRONIK	
F							
E							
D							
C				APPROVAL: JC	UNIT: MM	DESCRIPTION: DISCLAIMER	SIZE A4
B					SCALE:		
A	10-SEP-14	PDF	QL		SHEET: 1/1	WERI PART NO: DISCLAIMER	
REV	DATE	FILE	BY		DRAW: QL		

D