

172946001

MagI³C Power Module Product Family
LDHM - LED Step Down High Current Module



A DESCRIPTION

The LDHM series of the MagI³C Power Modules Family is a constant current Buck LED Driver Module. The MagI³C LED driver module drives a maximum load of 450 mA LED current and comprises a fully integrated current driver with passives all in one package. The MagI³C LED driver module provides a ready-made solution that is both highly efficient and it can be used for a variety of single string LED lighting applications. It requires an input voltage from 4.5 V to 60 V and provides a preset LED current of 350 mA. The LED current is adjustable from 300 mA to 450 mA by loading a single external resistor. The energy efficiency is up to 95 %.

The MagI³C LED driver module operates at a constant switching frequency of 800 kHz for low electromagnetic interference (EMI) and it is designed according to the standard EN55015. The module has a fast control loop to fine LED current pulse which is dissolved by 256 PWM steps at 240 Hz to implement for general lighting. Protection features include thermal shutdown, input under-voltage lockout, LED open-circuit and short-circuit protection. The MagI³C LED driver module is designed as an industrial high power density package with a low profile and a small outline (TO263-7EP).

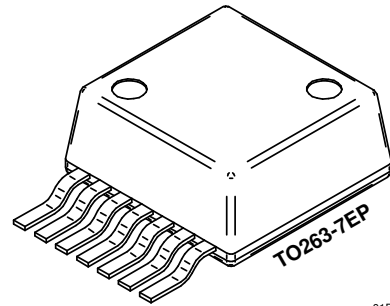

01P

B FEATURES

- Peak efficiency up to 95 %
- LED Current capability: 300 mA - 450 mA
- Wide input voltage range: 4.5 V - 60 V
- Drives 1 to 16 LEDs in series up to 60 V input
- Typical LED Current Accuracy ±3.5 %
- Switching Frequency fix at 800 kHz
- PWM Dimming
- High contrast ratio (min. PWM current < 16 μs)
- Integrated magnetics solution for ease of use
- Single exposed pad for best thermal performance
- Connectable in parallel for higher current operations
- Compatible with ceramic and Low ESR Capacitors
- Input under voltage lockout protection (UVLO)
- Temperature range: -40 °C - 125 °C

C APPLICATIONS

- Indoor lighting:
 - Spot light
 - Down light
- Outdoor lighting:
 - Street light
 - Security light
 - Tunnel light
- Industrial lighting:
 - High-bay light
 - Low-bay light

D TYPICAL APPLICATION CIRCUIT

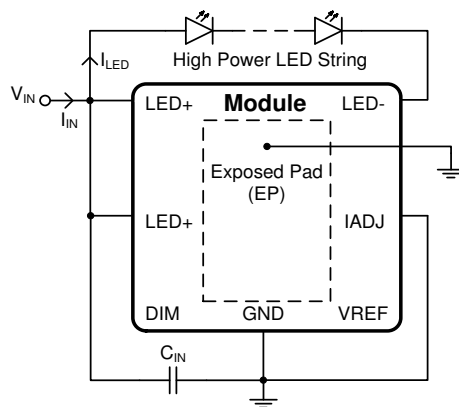

01S

I _{LED} (mA)	300	350	450
R _{IADJ} (Ω)	499	SHORT	SHORT
R _{VREF} (kΩ)	OPEN	OPEN	10.5



172946001

MagI³C Power Module Product Family
LDHM - LED Step Down High Current Module



E PACKAGE MARKING

Exposed Pad (EP)
 on the back side,
 Connect to GND

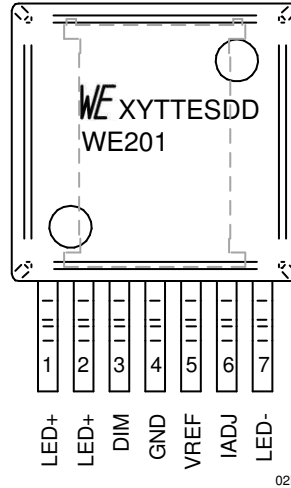

First row: Logo & Date code
 Second row: Product type

Top View TO263-7EP

F PIN DESCRIPTION

PIN #	PIN SYMBOL	PIN DESCRIPTION
1	LED+	Input power supply and anode connection of the LED string
2	LED+	Input power supply and anode connection of the LED string
3	DIM	Dimming control signal and open enable signal to control the brightness of the LED string
4	GND	Reference ground of the device connect to the EP externally
5	VREF	Internal voltage reference output
6	IADJ	LED current adjustment
7	LED-	Current return pin of the LED string, connect to the cathode of the LED string
EP	EP	Exposed Pad. Used for heat dissipation. Must be electrically connected to pin 4 GND

G ORDERING INFORMATION

ORDER CODE	PART DESCRIPTION	PACKAGE	PACKING UNIT
172946001	WLMDU9456001JT	TO263-7EP	Tape and Reel with 250 Units

H SALES INFORMATION

SALES CONTACTS

Würth Elektronik eiSos GmbH & Co. KG
 EMC & Inductive Solutions
 Max-Eyth-Str. 1
 74638 Waldenburg
 Germany
 Tel. +49 (0) 79 42 945 - 0
www.we-online.com
powermodules@we-online.de

172946001

MagI³C Power Module Product Family
LDHM - LED Step Down High Current Module



I ABSOLUTE MAXIMUM RATINGS ⁽¹⁾

Preventive Caution: Exceeding the listed absolute maximum ratings below may affect the device negatively and may cause permanent damage. Therefore operating ratings are conditions under which operation of the device is intended to be functional. All values are referenced to GND and to a free ambient operating temperature of $T_A = 25 \pm 5 \text{ }^\circ\text{C}$ unless otherwise specified.

SYMBOL	PARAMETER	LIMITS	UNIT
LED+, LED- to GND	LED Input and LED output to GND	-0.3 to 67	V
DIM to GND	PWM Dimming input to GND	-0.3 to 6	V
IADJ, VREF to GND	LED current Adjustment and Reference Pin to GND	-0.3 to 5	V
V _{ESD-HBM}	ESD, human body model ⁽²⁾ (All Pins except Pin 6)	-2000 to 2000	V
T _{JMAX}	Junction temperature	150	°C
T _{ST}	Storage temperature	0 to 150	°C

J RECOMMENDED OPERATING CONDITIONS ⁽¹⁾

SYMBOL	PARAMETER	MIN ⁽³⁾	TYP ⁽⁴⁾	MAX ⁽³⁾	UNIT
LED+, LED-	LED Input and LED output	4.5	-	60	V
DIM	PWM Dimming input	0	-	5.5	V
IADJ	LED current Adjustment	0	-	0.2	V
T _A	Ambient temperature range	-40	-	85	°C
T _J	Junction temperature range	-40	-	125	°C

K THERMAL SPECIFICATIONS

SYMBOL	PARAMETER	VALUE	UNIT
θ_{JA}	Thermal resistance junction to ambient ⁽⁵⁾	19.3	°C/W
θ_{JC}	Thermal resistance junction to case, no air flow	1.9	°C/W
T _{SD}	Thermal shut down, junction temperature, rising	170	°C
T _{SD-HYST}	Thermal shut down hysteresis, rising	10	°C
T _{SOLR}	Soldering temperature reflow, leads (30s) ⁽⁶⁾	245	°C

172946001

MagI³C Power Module Product Family

LDHM - LED Step Down High Current Module



L ELECTRICAL SPECIFICATIONS

Limits in standard type are for $T_J = 25\text{ °C}$ unless otherwise stated; limits in boldface type apply over the operating junction temperature range T_J of -40 °C to 125 °C . Minimum and maximum limits are specified through test, design, or statistical correlation. Typical values represent the most likely parametric norm at $T_J = 25\text{ °C}$, and are provided for reference purposes only. Unless otherwise stated the following conditions apply: $V_{IN} = 48\text{ V}$, $I_{LED} = 350\text{ mA}$. V_{IN} is the voltage applied across LED+ and GND. I_{IN} is the input current flowing into the LED+ node. I_{LED} is a LED current flowing into the LED- pin. V_{LED} is the voltage applied across LED+ and LED-. V_{DIM} is the voltage applied across the DIM pin to ground. Resistor R_{IADJ} connect from I_{ADJ} pin to ground. Resistor R_{VREF} connect from VREF pin to ground.

SYMBOL	PARAMETER	CONDITIONS	MIN ⁽³⁾	TYP ⁽⁴⁾	MAX ⁽³⁾	UNIT
Specifications regarding LED/input current						
I_{IN}	Input current		2.1	2.65	3.0	mA
I_{LED}	LED current	$V_{LED} = 24\text{V};$ $R_{IADJ} = 0\Omega;$ $R_{VREF} = \text{open};$ $T_J = -40\text{ °C to }125\text{ °C}$	337	350	371	mA
$I_{LED-60V}$	LED current $V_{IN} = 60\text{V}$	$V_{IN} = 60\text{V};$ $V_{LED} = 36\text{V};$ $R_{IADJ} = 0\Omega;$ $R_{VREF} = \text{open};$ $T_J = -40\text{ °C to }125\text{ °C}$	338	350	374	mA
$I_{LED-ADJ450}$	Adjustment LED current	$V_{LED} = 24\text{V};$ $R_{IADJ} = 0\Omega;$ $R_{VREF} = 10.5\text{k}\Omega;$ $T_J = -40\text{ °C to }125\text{ °C}$	437	450	483	mA
$I_{LED-ADJ300}$	Adjustment LED current	$V_{LED} = 24\text{V};$ $R_{IADJ} = 500\Omega;$ $R_{VREF} = \text{open};$ $T_J = -40\text{ °C to }125\text{ °C}$	282	300	316	mA
$I_{LED-SHORT}$	LED short circuit current $V_{IN} = 60\text{V}$	$V_{LED} = 0\text{V};$ $V_{IN} = 60\text{V};$ $\text{DIM} = \text{open}$	800	920	1020	mA
$I_{LED-LEAK}$	“LED-“ pin leakage current	$V_{LED} = 0\text{V};$ $V_{IN} = \text{operating max};$ $\text{DIM} = 0\text{V}$			1.2	μA
Specifications regarding PWM Dimming						
V_{DIM}	DIM pin threshold	V_{DIM} increasing		1.0	1.3	V
$V_{DIM-HYS}$	DIM pin hysteresis			0.25		V
Specifications regarding to the system						
f_{SW}	Switching frequency		0.72	0.8	0.92	MHz

NOTES

- (1) Absolute Maximum Ratings are limits beyond which damage to the device may occur. Operating Ratings are conditions under which operation of the device is intended to be functional. For guaranteed specifications and test conditions, see the Electrical Characteristics.
- (2) The human body model is a 100pF capacitor discharged through a 1.5 k Ω resistor into each pin. The Pin 6 (IADJ pin) pass $\pm 1\text{ kV}$. Test method is per JESD22-A114S.
- (3) Min and Max limits are 100 % production tested at 25 °C. Limits over the operating temperature range are guaranteed through correlation using Statistical Quality Control (SQC) methods. Limits are used to calculate Average Outgoing Quality Level (AOQL).
- (4) Typical numbers are at 25 °C and represent the most likely parametric norm.
- (5) θ_{JA} measured on a 43.3 mm x 76.2 mm four layer board, with 35 μm copper , thirty five 0.3 mm thermal vias, no air flow, and 1 W power dissipation.
- (6) JEDEC J-STD020

172946001

MagI³C Power Module Product Family
LDHM - LED Step Down High Current Module



M TYPICAL PERFORMANCE CURVES

If not otherwise specified, the following conditions apply: $V_{IN} = 28\text{ V}$; $C_{IN} = 2.2\ \mu\text{F}$ 100 V X7R Ceramic capacitor for driving 5-13 power LEDs, $I_{LED} = 350\text{ mA}$; Single LED forward voltage used is 3.2 V; $T_{AMB} = 25\text{ }^\circ\text{C}$

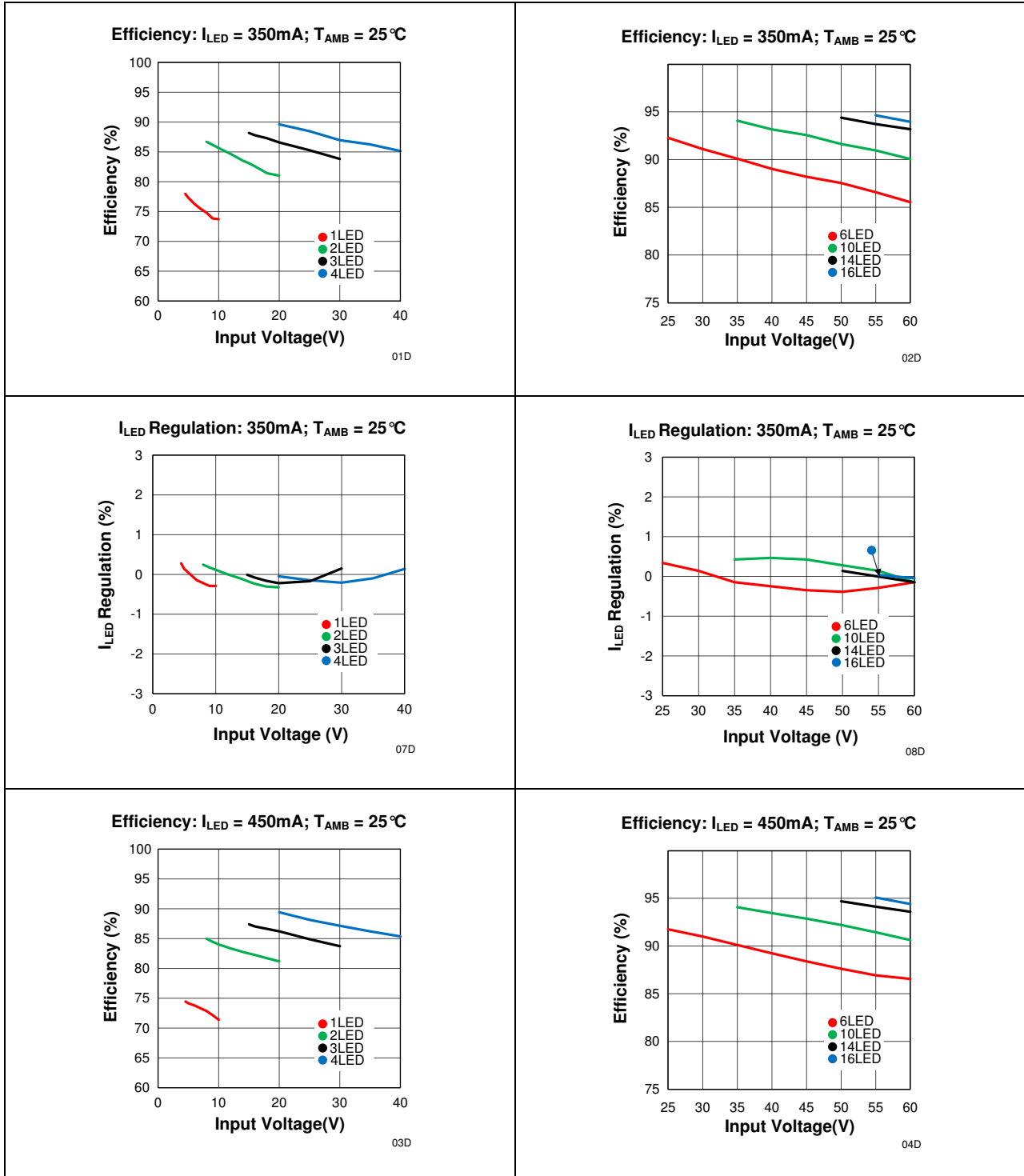

172946001

MagI³C Power Module Product Family
LDHM - LED Step Down High Current Module



TYPICAL PERFORMANCE CURVES

If not otherwise specified, the following conditions apply: $V_{IN} = 28\text{ V}$; $C_{IN} = 2.2\ \mu\text{F}$ 100 V X7R Ceramic capacitor for driving 5-13 power LEDs, $I_{LED} = 350\text{ mA}$; Single LED forward voltage used is 3.2 V; $T_{AMB} = 25^\circ\text{C}$

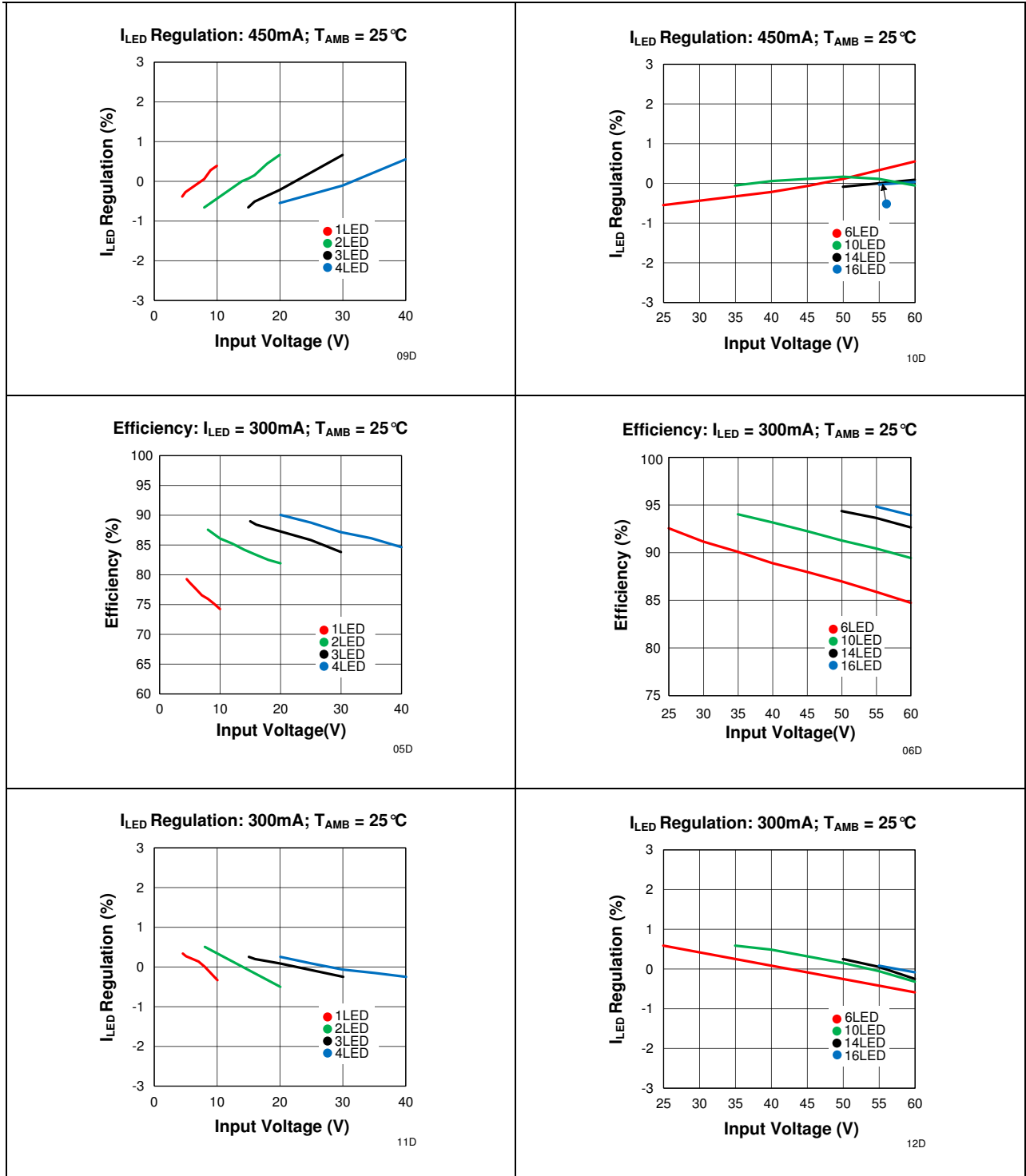

172946001

MagI³C Power Module Product Family
LDHM - LED Step Down High Current Module



TYPICAL PERFORMANCE CURVES

If not otherwise specified, the following conditions apply: $V_{IN} = 28\text{ V}$; $C_{IN} = 2.2\ \mu\text{F}$ 100 V X7R Ceramic capacitor for driving 5-13 power LEDs; $I_{LED} = 350\text{ mA}$; Single LED forward voltage used is 3.2 V; $T_{AMB} = 25^\circ\text{C}$

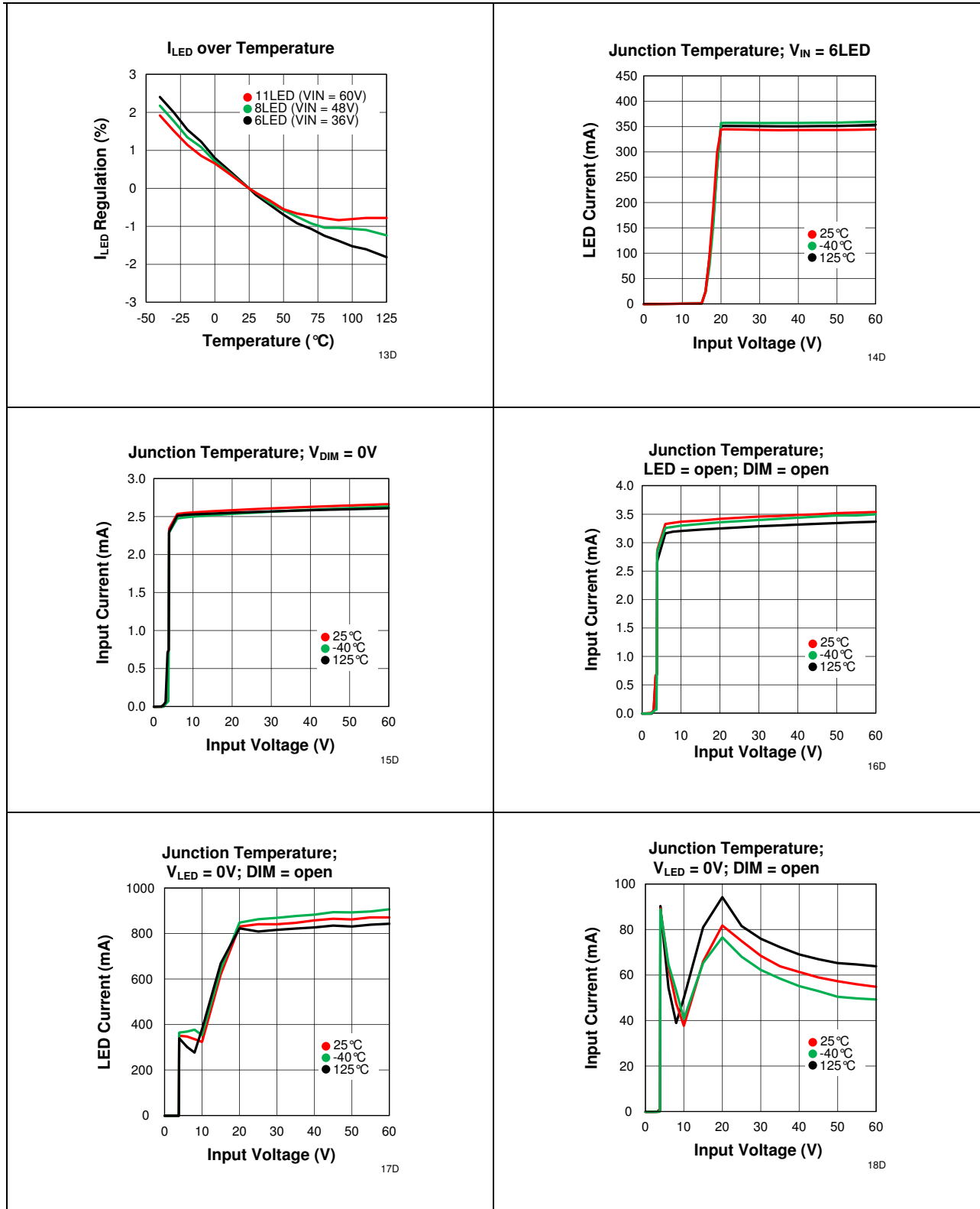

172946001

MagI³C Power Module Product Family
LDHM - LED Step Down High Current Module



TYPICAL PERFORMANCE CURVES

If not otherwise specified, the following conditions apply: $V_{IN} = 28\text{ V}$; $C_{IN} = 2.2\ \mu\text{F}$ 100 V X7R Ceramic capacitor for driving 5-13 power LEDs; $I_{LED} = 350\text{ mA}$; Single LED forward voltage used is 3.2 V; $T_{AMB} = 25\text{ }^\circ\text{C}$

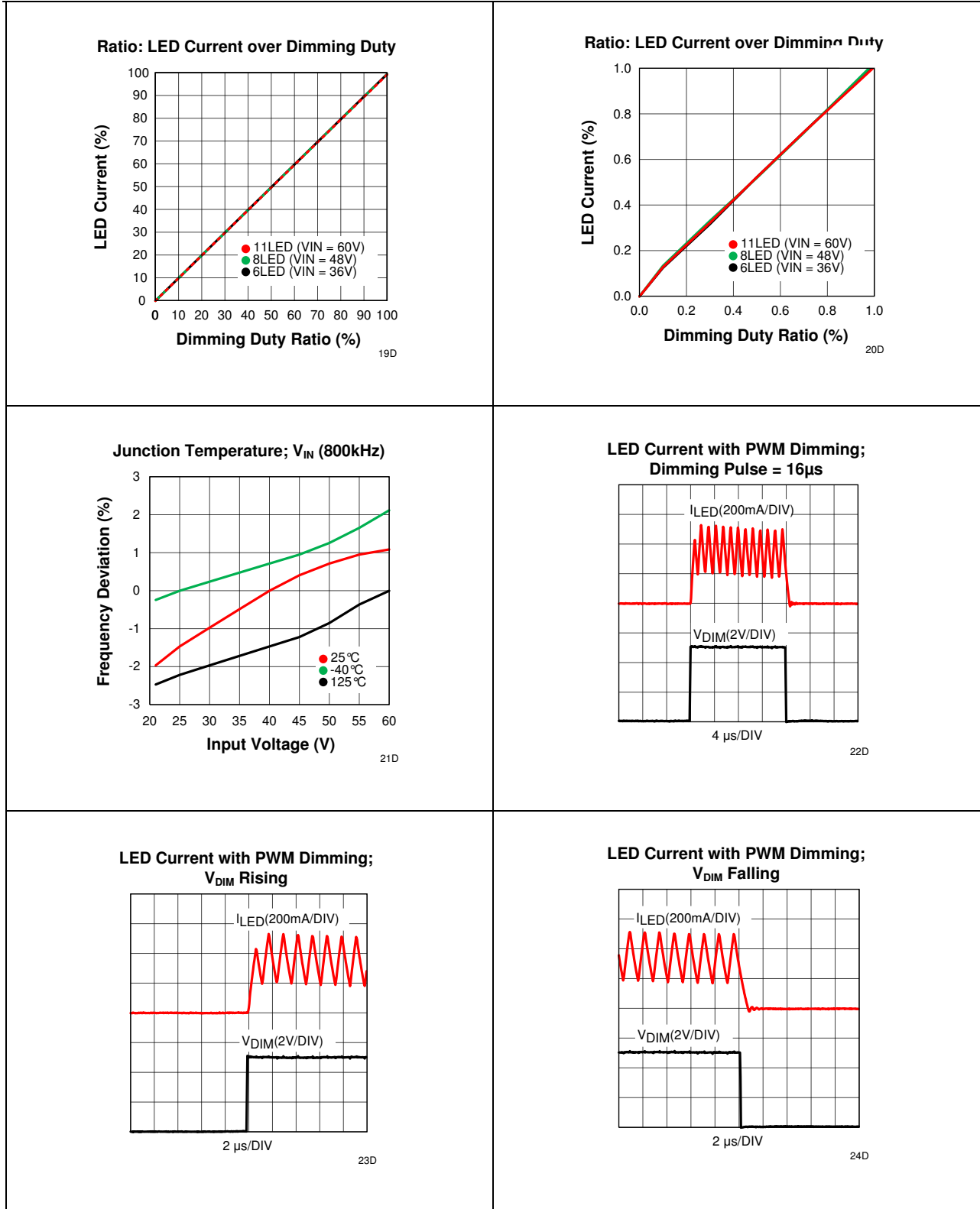

172946001

MagI³C Power Module Product Family
 LDHM - LED Step Down High Current Module



TYPICAL PERFORMANCE CURVES

If not otherwise specified, the following conditions apply: $V_{IN} = 28\text{ V}$; $C_{IN} = 2.2\ \mu\text{F}$ 100 V X7R Ceramic capacitor for driving 5-13 power LEDs, $I_{LED} = 350\text{ mA}$; Single LED forward voltage used is 3.2 V; $T_{AMB} = 25^\circ\text{C}$

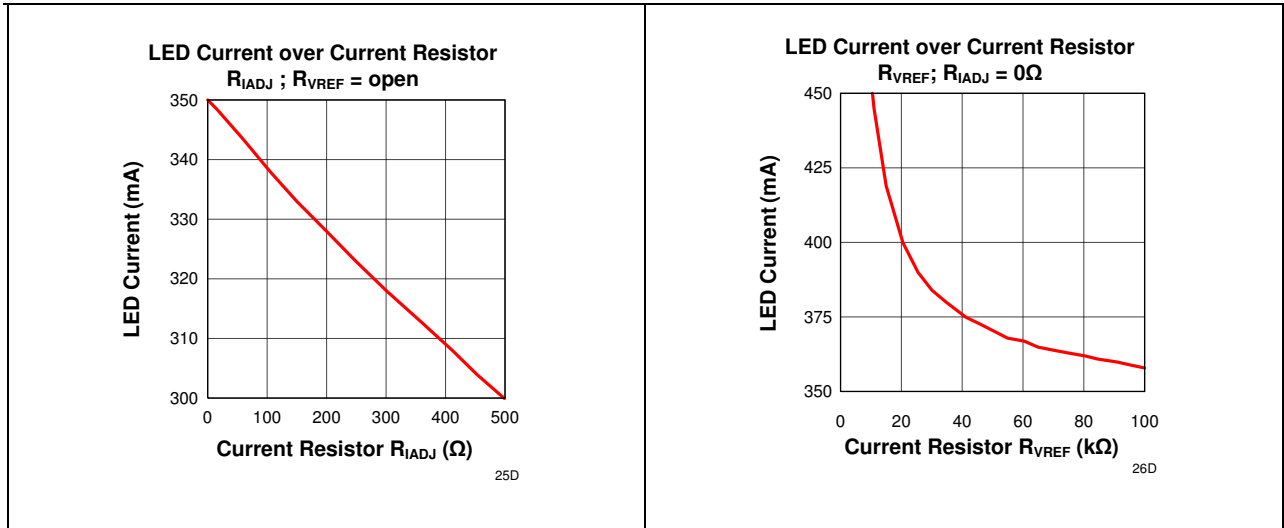

172946001

MagI³C Power Module Product Family
LDHM - LED Step Down High Current Module



N CIRCUIT DESCRIPTION

MagI³C 3+2 Steps to design the current driver application

The next 5 simple steps will show how to select the external components to design your power application:

1. Program the LED driver module current
2. Layout considerations
3. EMI design considerations
4. Optional: Dimming control
5. Optional: Parallel operation

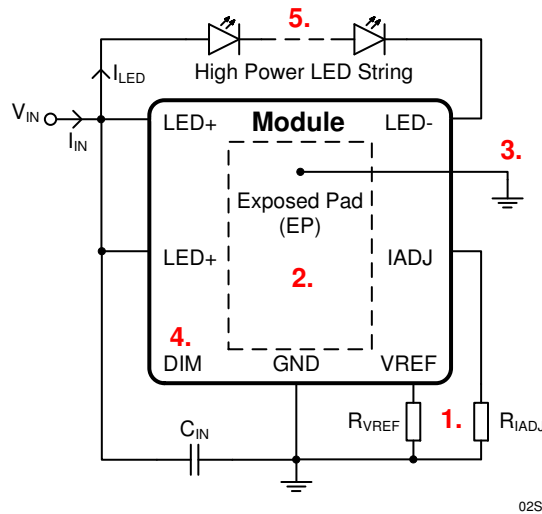

Step 1. Program the LED driver module current

The LED driver module requires no external current sensing resistor for LED current regulation. The average LED current of the LED driver module is adjustable from 300 mA to 450 mA by varying the resistance of the resistor according to the following equation and table.

Conditions:

$R_{VREF} = \text{open}; R_{IADJ} \leq 499 \Omega$

$$I_{LED} = \frac{1050}{3k + R_{IADJ}} \tag{1}$$

Conditions:

$R_{IADJ} = 0; R_{VREF} \geq 10.5 \text{ k}\Omega$

$$I_{LED} = \frac{1050}{3k // R_{VREF}} \tag{2}$$

Recommended Values:

I_{LED}(mA)	300	350	450
R_{IADJ}(Ω)	499	short	short
R_{VREF}(Ω)	open	open	10.5k

Maximum Switch Current Limit

The LED Driver Module features an integrated switch current limiting mechanism to prevent the LEDs from being overdriven. The switch current limiter is triggered when the switch current is three times exceeding the current level set by resistor. Once the current limiter is triggered, the internal power switch turn OFF for 3.6 μs to discharge the inductor until inductor current reduces back to normal level. The current limiting feature is exceptionally important to avoid permanent damage of the LED driver module application circuit due to short circuit of LED string.

172946001

MagI³C Power Module Product Family

LDHM - LED Step Down High Current Module



Minimum Switch On-Time

The on-time of the internal switch should be no shorter than 400 ns. The number of LED (typical forward voltage at 3.2 V) to input voltage is constrained by that as shown in the following table.

No. of LED	1	2	3	4	5	6-16
Max. V_{IN} (V)	10	20	30	40	50	60

Step 2. Layout consideration

The overall performance of the LED driver module highly depends on the PCB layout. Poor board layout can disrupt the performance of the LED driver module and surrounding circuitry by contributing to EMI, ground bounce and resistive voltage drop in the traces. These can send incorrect signals to the LED driver module resulting in poor regulation and stability. Good layout can be implemented by following a few simple design rules.

- Place C_{IN} as close as possible to the V_{IN} pin and GND exposed pad (EP).
- Place C_{OUT} (optional for reduction of LED current ripple and EMI compliance) as close as possible to the VLED+ pin and VLED- pin.
- The exposed pad (EP) must be connected to the GND pin directly.

Step 3. EMI design considerations

From an EMI reduction standpoint, it is imperative to minimize the di/dt current paths (refer to LED driver module current loops). Therefore, it is essential to connect a 2.2 μF capacitor (C_{OUT}) across the LED+ pin and LED- pin. This will minimize the ripple current so that it can reduce radiated EMI.

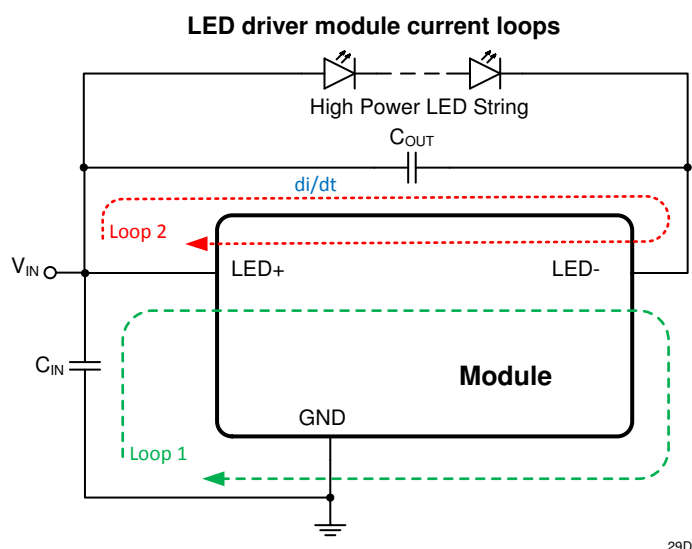

172946001

MagI³C Power Module Product Family
LDHM - LED Step Down High Current Module



Step 4. Dimming Control

The DIM pin of the LED driver module is an input with internal pull-up that accepts logic signals for average LED current control. Applying a logic high (above 1.3 V) signal to the DIM pin or leaving the DIM pin open will enable the device. Applying a logic low signal (below 0.7 V) to the DIM pin will disable the switching activity of the device but maintain operation of the VCC regulator active. The LED driver module operation of high speed dimming and very fine dimming control is shown below.

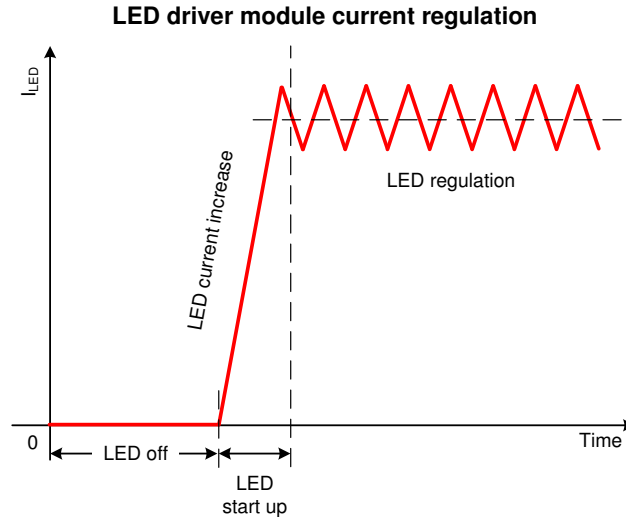

30D

Step 5. Parallel operation

When a load current higher than 450 mA is required by the application, LED driver module can be used in parallel to deliver higher current. With common V_{INs} and $GNDs$, the LED driver module will operate as independent asynchronous current sinks driving the same LED load. The total DC current of the modules will be additive; however, low frequency sub-harmonic current ripple may be present and its frequency and magnitude will depend upon the phase relationship between the internal clocks as there is no provision for synchronizing driver clocks. It is suggested to have minimum 2.2 μF C_{OUT} located close the module to filter out the current ripple, and the resultant LED current will become DC. Current sharing modules should have a local C_{IN} capacitor of minimum 2.2 μF located as close to V_{IN} and GND as possible. Refer to "Parallel operation circuit schematic" for the LED driver module parallel operation circuit schematic. Refer to "Parallel operation result" for the LED driver module parallel operation results I_{LED} vs V_{IN} .

Parallel operation circuit schematic

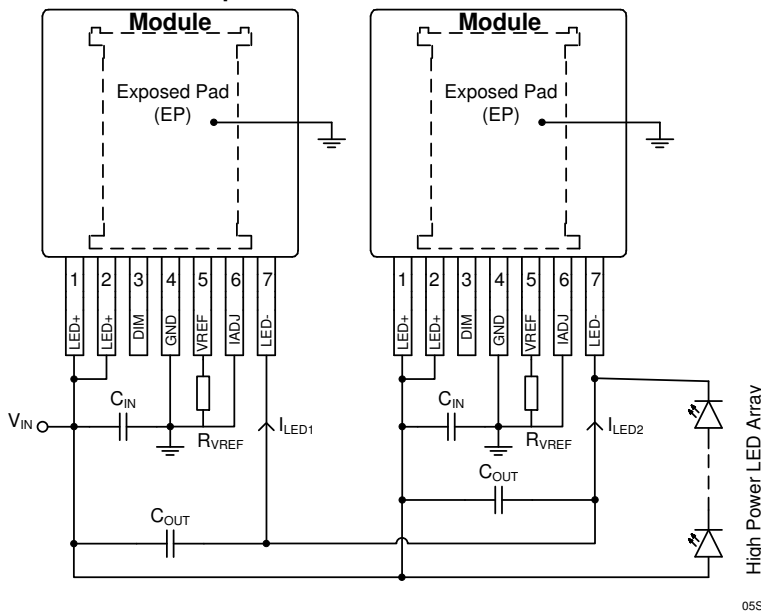

Parallel operation result; $I_{LED} = 900mA$

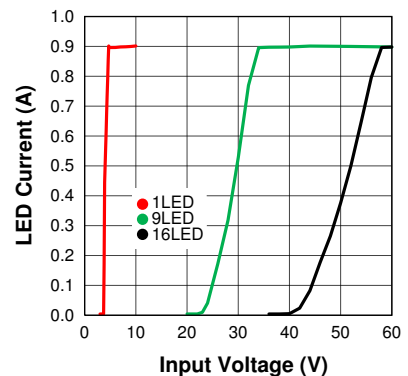

05S

31D

172946001

MagI³C Power Module Product Family
 LDHM - LED Step Down High Current Module



O BLOCK DIAGRAM

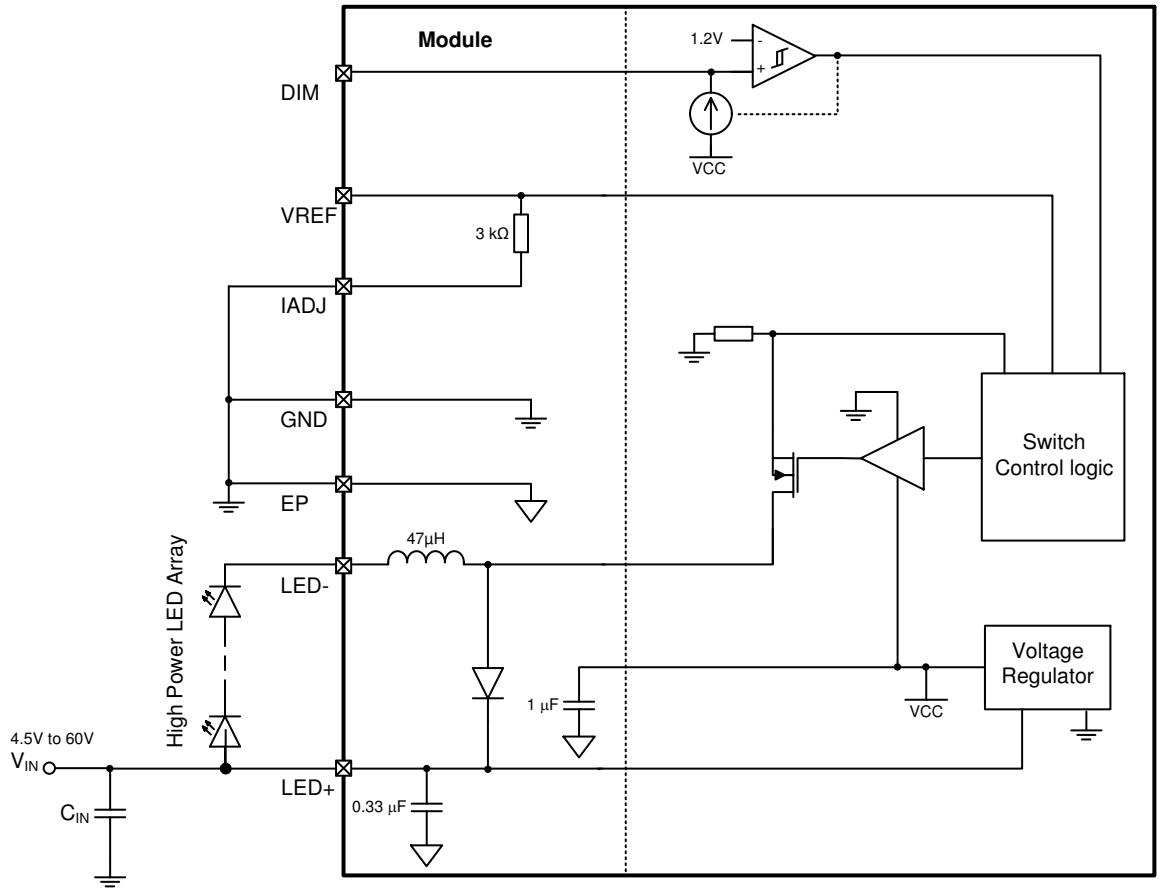

10S

172946001

MagI³C Power Module Product Family
LDHM - LED Step Down High Current Module



P PIN CONFIGURATION

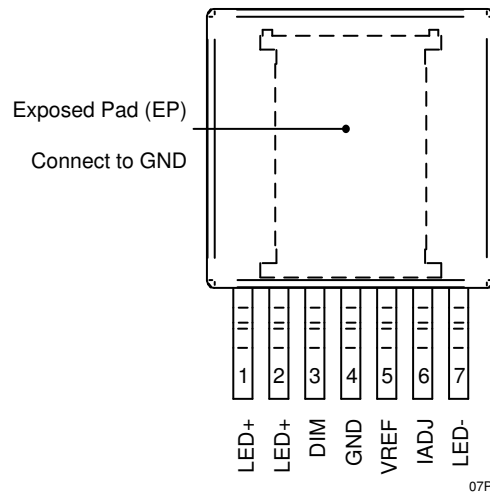

Top View TO263-7EP

Q DETAILED PIN DESCRIPTION

PIN #	PIN SYMBOL	TYPE	PIN DESCRIPTION
1,2	LED+	PWR	Supply input and rail connection to the anode of the LED string.
3	DIM	I	Dimming control signal input. Open to enable or apply logic level PWM signal to control the brightness of the LED string.
4	GND	PWR	Reference point for all stated voltages. Connect to the exposed pad of the package externally.
5	VREF	I	Internal voltage reference output.
6	IADJ	I	Fine tuning of the LED current by connecting a resistor between this pin and ground. Connect this pin to ground for factory preset current.
7	LED-	O	The current return pin of the LED string, connect to the cathode of the LED string.
EP	EP	Exposed Pad	Exposed Pad – Internally connected to pin 4. Used to dissipate heat during operation. Must be electrically connected to pin 4 external to package

172946001

MagI³C Power Module Product Family
LDHM - LED Step Down High Current Module



R APPLICATIONS

The MagI³C LED driver module for constant current is easy-to-use for current solutions capable of driving up to a 450 mA load with exceptional power conversion efficiency. They are available in an innovative package that enhances thermal performance and allows for hand or machine soldering. Following application circuits show possible operating configurations.

R1 APPLICATION CIRCUIT

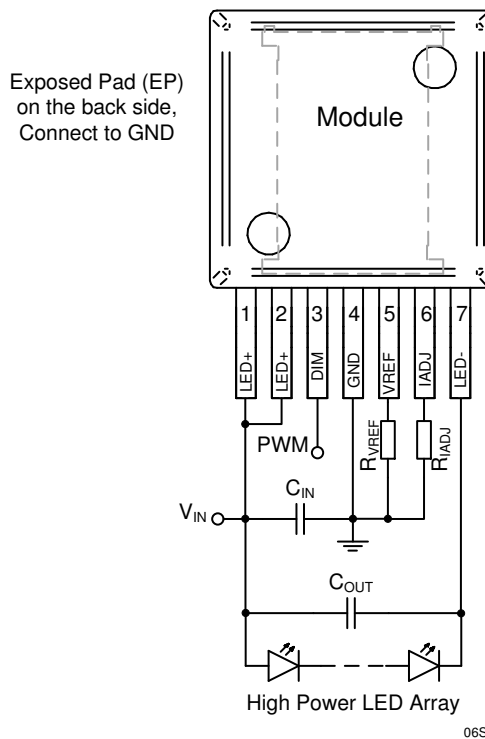

R1a Bill of Materials for Design Example:

Recommended component values: $T_A = 25^\circ\text{C}$; $V_{IN} = \text{up to } 60\text{V}$; LEDs up to 16; * parts for better EMI

I_{LED}	300 mA	350 mA	450 mA
R_{IADJ}	499 k Ω	short	short
R_{VREF}	open	open	10.5 k Ω
C_{IN}	2.2 μF ; 100 V ; X7R		
C_{OUT}^*	2.2 μF ; 100 V ; X7R		

172946001

MagI³C Power Module Product Family
LDHM - LED Step Down High Current Module



S PHYSICAL DIMENSIONS (mm)

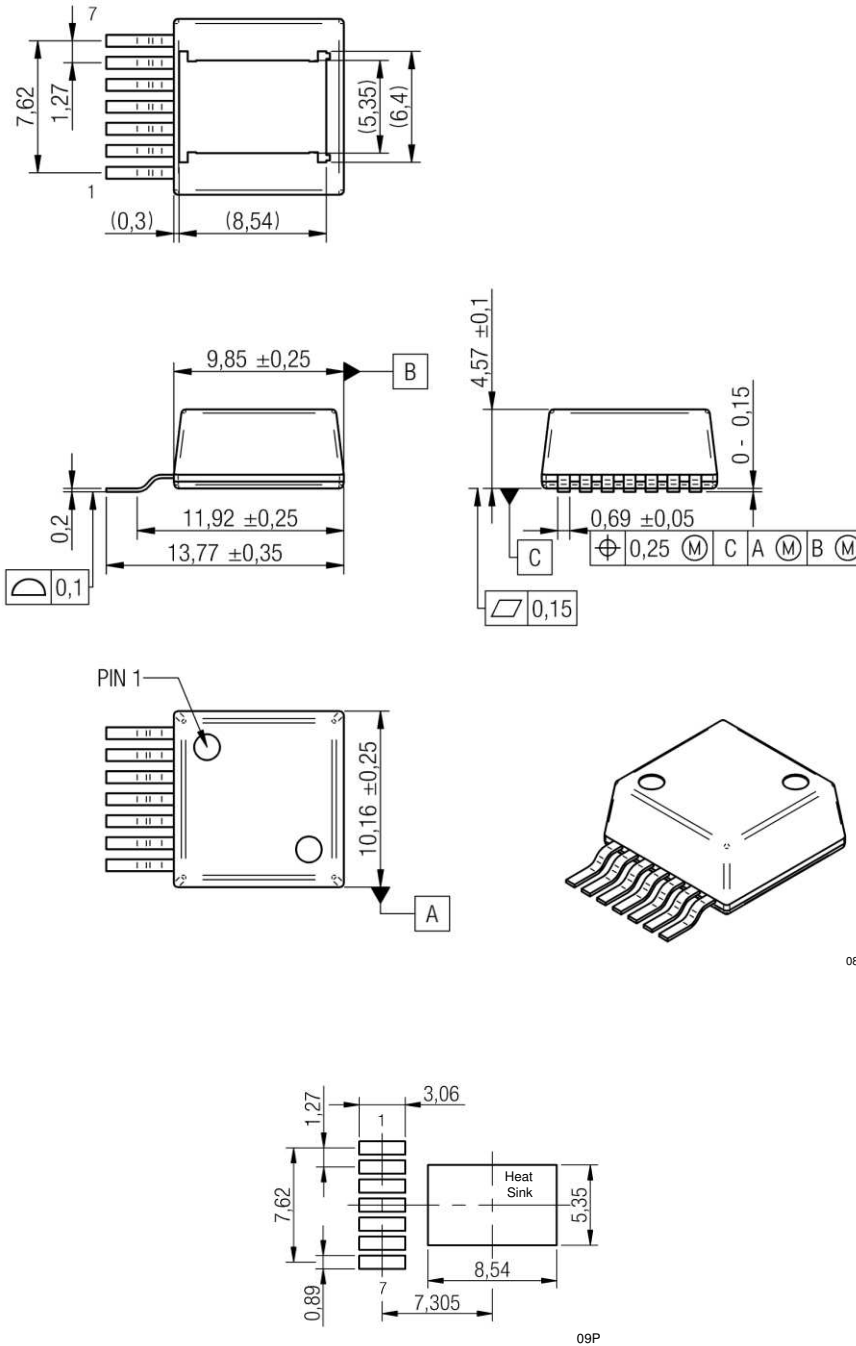

recommended soldering pad
solder past recommendation 150 µm

172946001

MagI³C Power Module Product Family
LDHM - LED Step Down High Current Module



T Packaging

T1 Reel (mm)

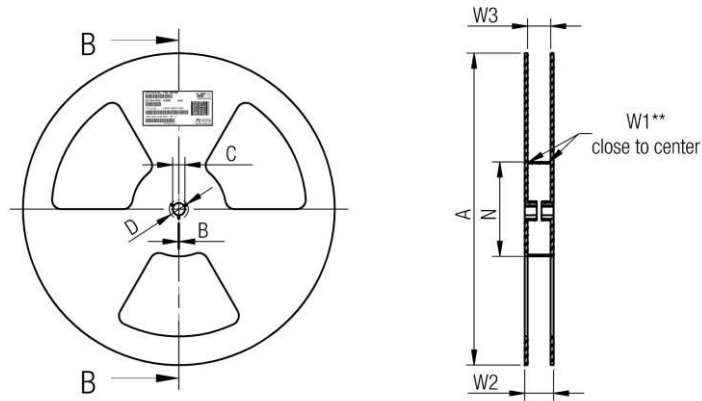

	A	B	C	D	N	W1	W2	W3	W3	
tolerance	± 2,0	min.	± 0,8	min.	± 2,0	+ 2	max.	min.	max.	
Tape width	24mm	330,00	1,50	13,00	20,20	60,00	24,40	30,40	23,90	27,40

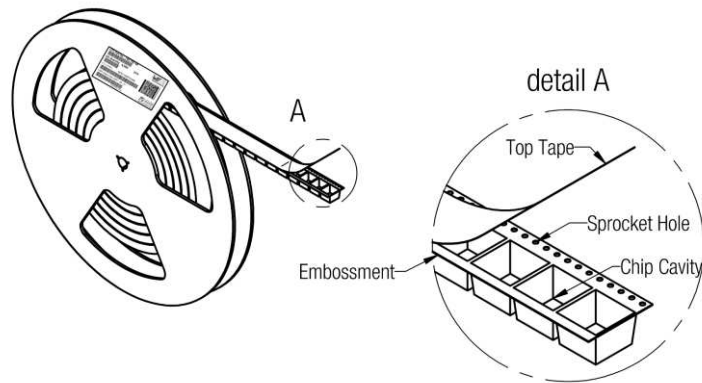

20P

172946001

MagI³C Power Module Product Family LDHM - LED Step Down High Current Module



T2 Tape (mm)

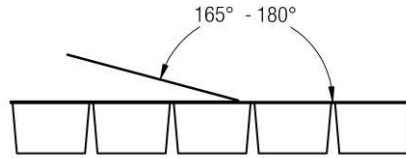

Tape width	24 mm	Pull-of force
		0,1 N - 1,3 N

21P

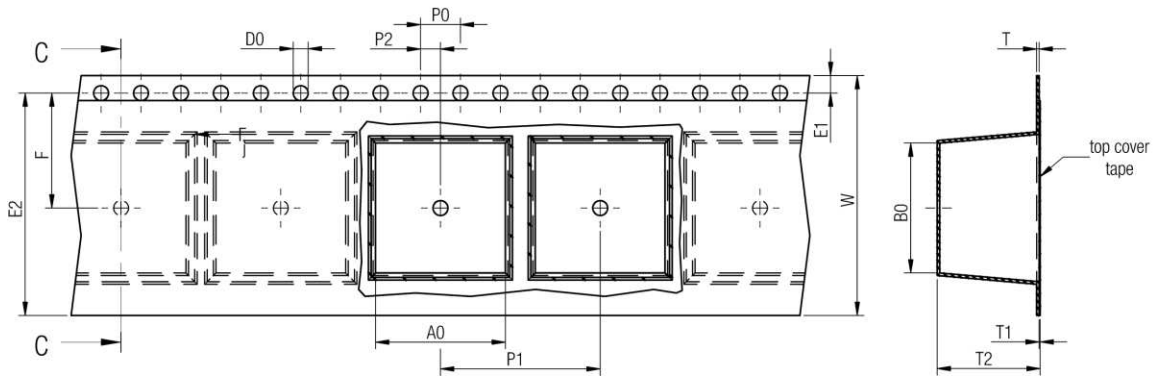

	A0	B0	W	P1	T	T1	T2	D0	E1	E2	F	P0	P2	Tape	VPE / packaging unit
tolerance	typ.	typ.	+0,3 -0,1	± 0,1	± 0,1	max.	typ.	+0,3 -0,1	± 0,1	min.	± 0,05	± 0,1	± 0,05		
size	TO263-7EP	10,60	14,22	24,00	16,00	0,10	5,00	1,50	1,75	22,25	11,50	4,00	2,00	Polystyrene	250

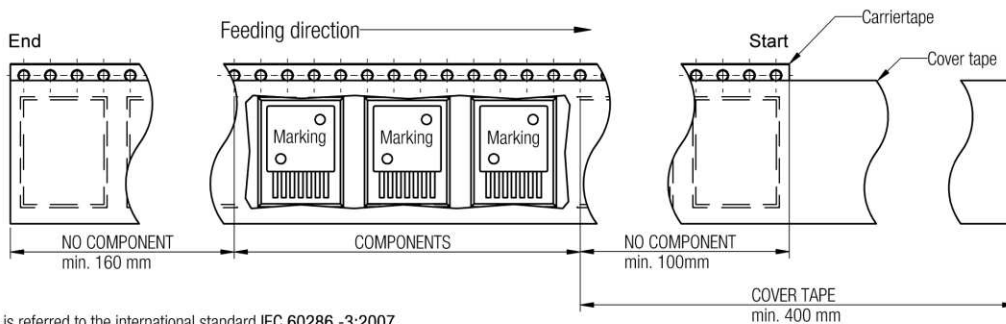

Packaging is referred to the international standard IEC 60286 -3:2007

22P

172946001

MagI³C Power Module Product Family
LDHM - LED Step Down High Current Module

**U DOCUMENT HISTORY****DOCUMENT HISTORY**

Revision	Date	Description	Responsible
0.1	13.02.2014	First draft	Michael Berger

172946001

MagI³C Power Module Product Family
LDHM - LED Step Down High Current Module



CAUTIONS AND WARNINGS

The following conditions apply to all goods within the product series of MagI³C of Würth Elektronik eiSos GmbH & Co. KG:

General:

All recommendations according to the general technical specifications of the data-sheet have to be complied with.

The disposal and operation of the product within ambient conditions which probably alloy or harm the component surface has to be avoided.

If the product is potted in customer applications, the potting material might shrink during and after hardening. Accordingly to this the product is exposed to the pressure of the potting material with the effect that the body and termination is possibly damaged by this pressure and so the electrical as well as the mechanical characteristics are endanger to be affected. After the potting material is cured, the body and termination of the product have to be checked if any reduced electrical or mechanical functions or destructions have occurred.

The responsibility for the applicability of customer specific products and use in a particular customer design is always within the authority of the customer. All technical specifications for standard products do also apply for customer specific products.

Washing varnish agent that is used during the production to clean the application might damage or change the characteristics of the body, pins or termination. The washing varnish agent could have a negative effect on the long turn function of the product.

Direct mechanical impact to the product shall be prevented as the material of the body, pins or termination could flake or in the worst case it could break. As these devices are sensitive to electrostatic discharge customer shall follow proper IC Handling Procedures.

Customer acknowledges and agrees that it is solely responsible for compliance with all legal, regulatory and safety-related requirements concerning its products, and any use of Würth Elektronik eiSos GmbH & Co. KG components in its applications, notwithstanding any applications-related information or support that may be provided by Würth Elektronik eiSos GmbH & Co. KG. Customer represents and agrees that it has all the necessary expertise to create and implement safeguards which anticipate dangerous consequences of failures, monitor failures and their consequences lessen the likelihood of failures that might cause harm and take appropriate remedial actions. Customer will fully indemnify Würth Elektronik eiSos and its representatives against any damages arising out of the use of any Würth Elektronik eiSos GmbH & Co. KG components in safety-critical applications.

Product specific:

Follow all instructions mentioned in the datasheet, especially:

- The solder profile has to be complied with according to the technical reflow/ or wave soldering specification, otherwise no warranty will be sustained.
- All products are supposed to be used before the end of the period of 12 months based on the product date-code, if not a 100% solderability can't be warranted.
- Violation of the technical product specifications such as exceeding the absolute maximum ratings will result in the loss of warranty.
- It is also recommended to return the body to the original moisture proof bag and reseal the moisture proof bag again.
- ESD prevention methods need to be followed for manual handling and processing by machinery.

172946001

MagI³C Power Module Product Family
LDHM - LED Step Down High Current Module



IMPORTANT NOTES

The following conditions apply to all goods within the product range of Würth Elektronik eiSos GmbH & Co. KG:

1. General Customer Responsibility

Some goods within the product range of Würth Elektronik eiSos GmbH & Co. KG contain statements regarding general suitability for certain application areas. These statements about suitability are based on our knowledge and experience of typical requirements concerning the areas, serve as general guidance and cannot be estimated as binding statements about the suitability for a customer application. The responsibility for the applicability and use in a particular customer design is always solely within the authority of the customer. Due to this fact it is up to the customer to evaluate, where appropriate to investigate and decide whether the device with the specific product characteristics described in the product specification is valid and suitable for the respective customer application or not. Accordingly, the customer is cautioned to verify that datasheet are current before placing orders.

2. Customer Responsibility related to Specific, in particular Safety-Relevant Applications

It has to be clearly pointed out that the possibility of a malfunction of electronic components or failure before the end of the usual lifetime cannot be completely eliminated in the current state of the art, even if the products are operated within the range of the specifications. In certain customer applications requiring a very high level of safety and especially in customer applications in which the malfunction or failure of an electronic component could endanger human life or health it must be ensured by most advanced technological aid of suitable design of the customer application that no injury or damage is caused to third parties in the event of malfunction or failure of an electronic component.

3. Best Care and Attention

Any product-specific notes, warnings and cautions must be strictly observed.

4. Customer Support for Product Specifications

Some products within the product range may contain substances which are subject to restrictions in certain jurisdictions in order to serve specific technical requirements. Necessary information is available on request. In this case the field sales engineer or the internal sales person in charge should be contacted who will be happy to support in this matter.

5. Product R&D

Due to constant product improvement product specifications may change from time to time. As a standard reporting procedure of the Product Change Notification (PCN) according to the JEDEC-Standard inform about minor and major changes. In case of further queries regarding the PCN, the field sales engineer or the internal sales person in charge should be contacted. The basic responsibility of the customer as per Section 1 and 2 remains unaffected.

6. Product Life Cycle

Due to technical progress and economical evaluation we also reserve the right to discontinue production and delivery of products. As a standard reporting procedure of the Product Termination Notification (PTN) according to the JEDEC-Standard we will inform at an early stage about inevitable product discontinuance. According to this we cannot guarantee that all products within our product range will always be available. Therefore it needs to be verified with the field sales engineer or the internal sales person in charge about the current product availability expectancy before or when the product for application design-in disposal is considered. The approach named above does not apply in the case of individual agreements deviating from the foregoing for customer-specific products.

7. Property Rights

All the rights for contractual products produced by Würth Elektronik eiSos GmbH & Co. KG on the basis of ideas, development contracts as well as models or templates that are subject to copyright, patent or commercial protection supplied to the customer will remain with Würth Elektronik eiSos GmbH & Co. KG. Würth Elektronik eiSos GmbH & Co. KG does not warrant or represent that any license, either expressed or implied, is granted under any patent right, copyright, mask work right, or other intellectual property right relating to any combination, application, or process in which Würth Elektronik eiSos GmbH & Co. KG components or services are used.

8. General Terms and Conditions

Unless otherwise agreed in individual contracts, all orders are subject to the current version of the "General Terms and Conditions of Würth Elektronik eiSos Group", last version available at www.we-online.com.