

# Specification for release

Customer : \_\_\_\_\_  
 Ordercode: **8240136**  
 Description: **TVS Diode Array WE-TVS**  
 Package: **SOT143-4L**



DATUM / DATE : 2010-01-27

## A Features:

- ESD Protection for 2 high-speed I/O channels and VDD
- Provide ESD protection for each channel to  
 IEC 61000-4-2 (ESD)  $\pm 15\text{kV}$  (air),  $\pm 8\text{kV}$  (contact)  
 IEC 61000-4-4 (EFT) 80A (5/50ns)  
 IEC 61000-4-5 (Lightning) 12A (8/20 $\mu\text{s}$ )
- Below 3.3V operating voltage: 2.5 - 3.3V
- Low capacitance: 3pF typical

## Mechanical Characteristics:

- JEDEC SOT143-4L Package
- Molding compound flamability rating: UL94V-0
- Packaging: Tape & Reel

## B Schematic and Pin Configuration:

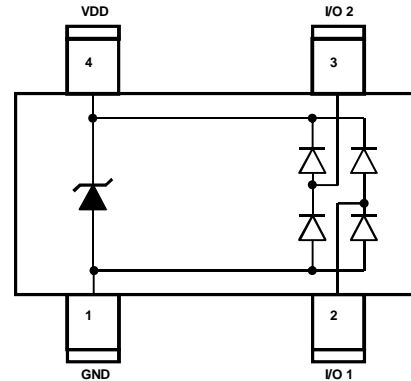

## C Absolute Maximum Ratings:

	Symbol	Rating	Unit
Peak Pulse Current (tp = 8/20 $\mu\text{s}$ )	$I_{PP}$	12	A
Operating Supply Voltage, VDD to GND	$V_{DC}$	3.8	V
ESD per IEC 61000-4-2 (Air / Contact), I/O to GND	$V_{ESD,I/O}$	30 / 24	kV
ESD per IEC 61000-4-2 (Air / Contact), VDD to GND	$V_{ESD,VDD}$	30 / 24	kV
DC Voltage at any I/O Pin	$V_{IO}$	(GND -0,5) to (VDD +0,5)	V
Operating Temperature	$T_{Op}$	-55 to +125	$^{\circ}\text{C}$
Storage Temperature	$T_{Sto}$	-20 to +60	$^{\circ}\text{C}$

## D Electrical Characteristics:

Properties	Test Conditions	Value min	Value typ	Value max	Unit
$V_{RWM}$	Pin 4 to Pin 1			3.3	V
$V_{BV}$	$I_{BV}=1\text{mA}$ , Pin 4 to Pin 1	4.5			V
$I_R$	$V_{Pin5}=5\text{V}$ , Pin 4 to Pin 1			5	$\mu\text{A}$
$V_F$	$I_F = 15\text{mA}$ , Pin 1 to Pin 4	0.6		1	V
$V_C$	$I_{PP}=5\text{A}$ , tp=8/20 $\mu\text{s}$ , I/O to GND		6.0		V
$V_{Cl,I/O}$	$I_{TLP} = 17\text{A}$ , I/O to GND		9.0		V
$C_{IO}$	$V_{Pin4}=4\text{V}$ , $V_{Pin1}=0\text{V}$ , $V_{IO}=2.5\text{V}$ , $f=1\text{MHz}$ , I/O to GND		3.0	3.5	pF
$C_X$	$V_{Pin4}=5\text{V}$ , $V_{Pin1}=0\text{V}$ , $V_{IO}=2.5\text{V}$ $f=1\text{MHz}$ , between I/O pins		0.4	0.6	pF

## Würth Elektronik eiSos GmbH & Co. KG

D-74638 Waldenburg · Max-Eyth-Strasse 1 · Germany · Phone (+49) (0) 7942 - 945 - 0 · Fax (+49) (0) 7942 - 945 - 400

<http://www.we-online.com>

# Specification for release

Customer : \_\_\_\_\_  
 Ordercode: **8240136**  
 Description : **TVS Diode Array WE-TVS**  
 Package: **SOT143-4L**



DATUM / DATE : 2010-01-27

## E Typical Characteristics:

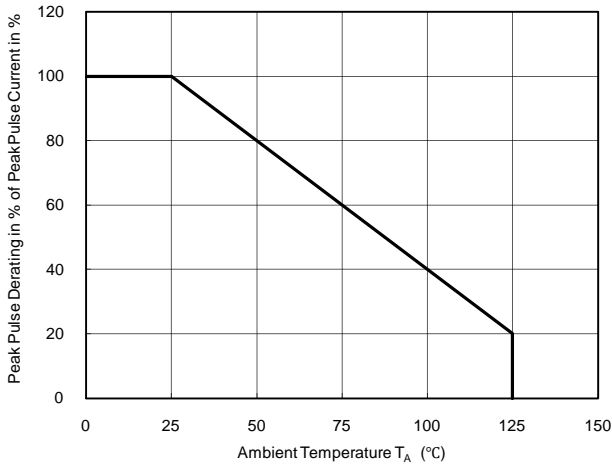

**Power Derating Curve**

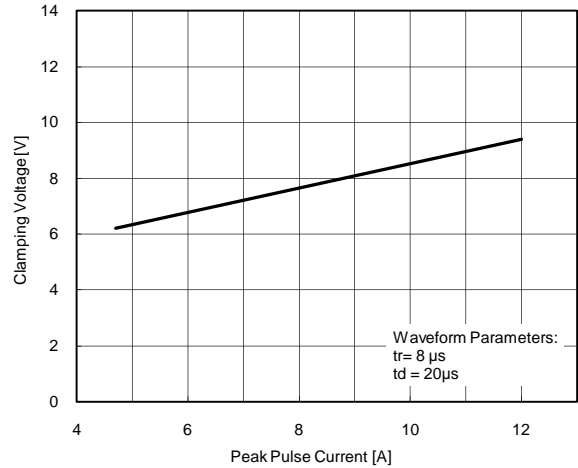

**Clamping Voltage vs. Peak Pulse Current**

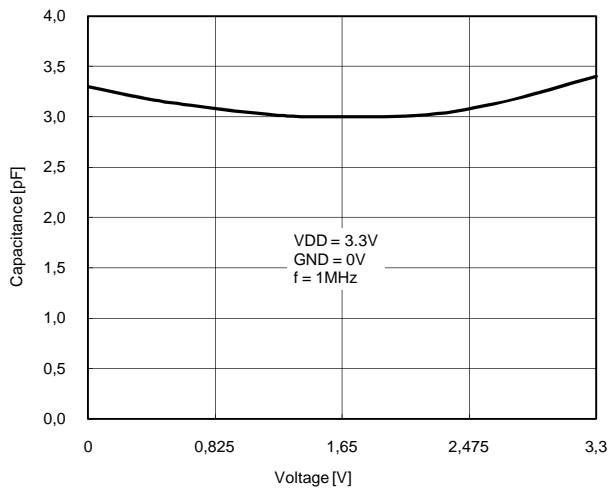

**Variation of C<sub>IO</sub> vs. V<sub>IO</sub>**

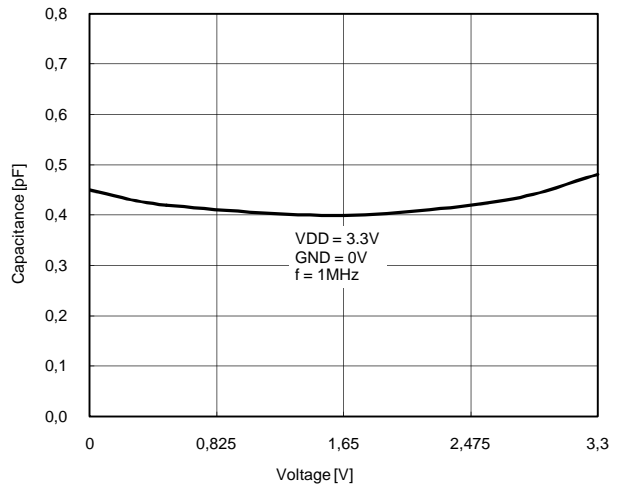

**Variation of C<sub>X</sub> vs. V<sub>IO</sub>**

# Specification for release

Customer : \_\_\_\_\_  
 Ordercode: **8240136**  
 Description : **TVS Diode Array WE-TVS**  
 Package: **SOT143-4L**



DATUM / DATE : 2010-01-27

## E Typical Characteristic:

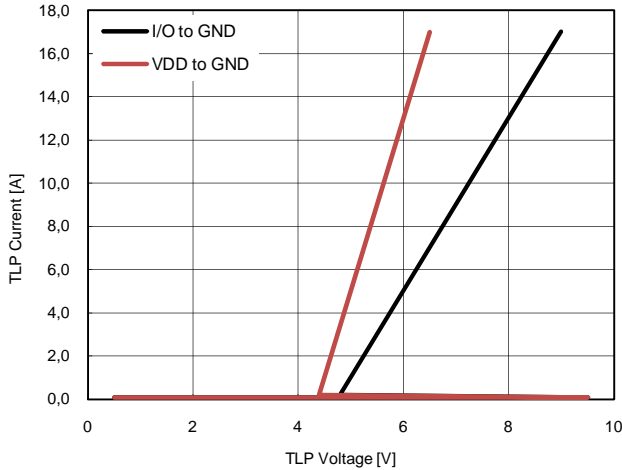

Transmission Line Pulsing (TLP) Measurement

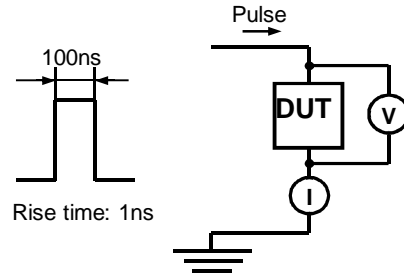

Transmission Line Pulsing System

## F Recommended Land Layout:

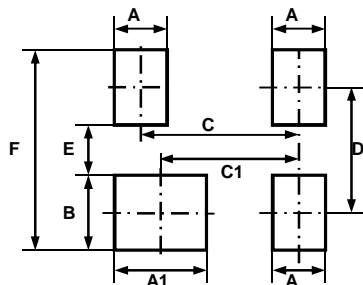

A	1.00	mm
A1	1.40	mm
B	1.40	mm
C	1.90	mm
C1	1.70	mm
D	2.20	mm
E	0.80	mm
F	3.60	mm

## G Body Marking:

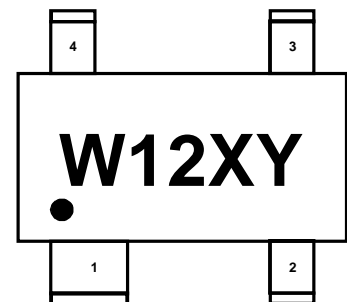

W12: Device Code

X: Date Code

Y: Control Code

## Würth Elektronik eiSos GmbH & Co. KG

D-74638 Waldenburg · Max-Eyth-Strasse 1 · Germany · Phone (+49) (0) 7942 - 945 - 0 · Fax (+49) (0) 7942 - 945 - 400

<http://www.we-online.com>

PAGE 3 OF 5

# Specification for release

Customer : \_\_\_\_\_  
Ordercode: **8240136**  
Description : **TVS Diode Array WE-TVS**  
Package: **SOT143-4L**



DATUM / DATE : 2010-01-27

## H Dimensions:

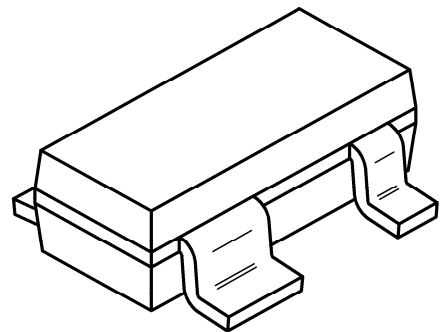
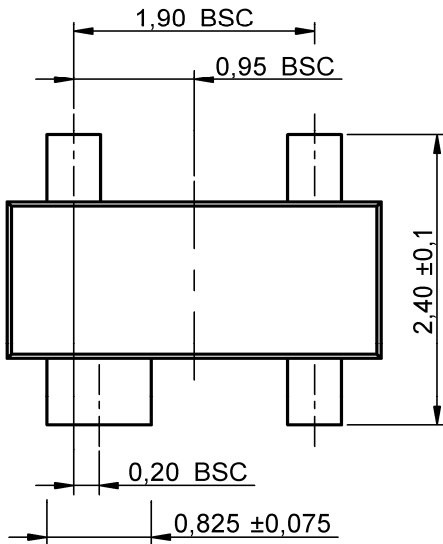
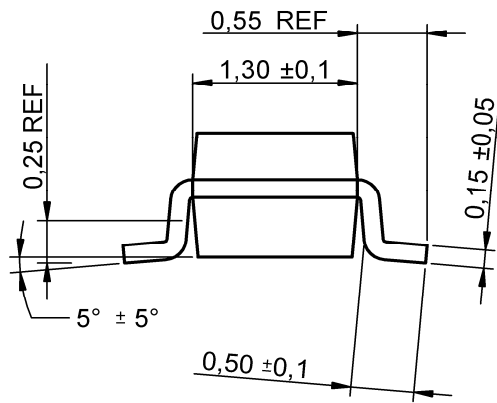
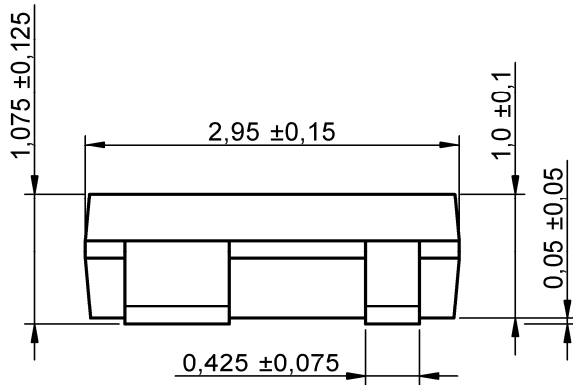

Scale - 10:1

# Specification for release

Customer : \_\_\_\_\_  
 Ordercode: **8240136**  
 Description : **TVS Diode Array WE-TVS**  
 Package: **SOT143-4L**



## I Tape:

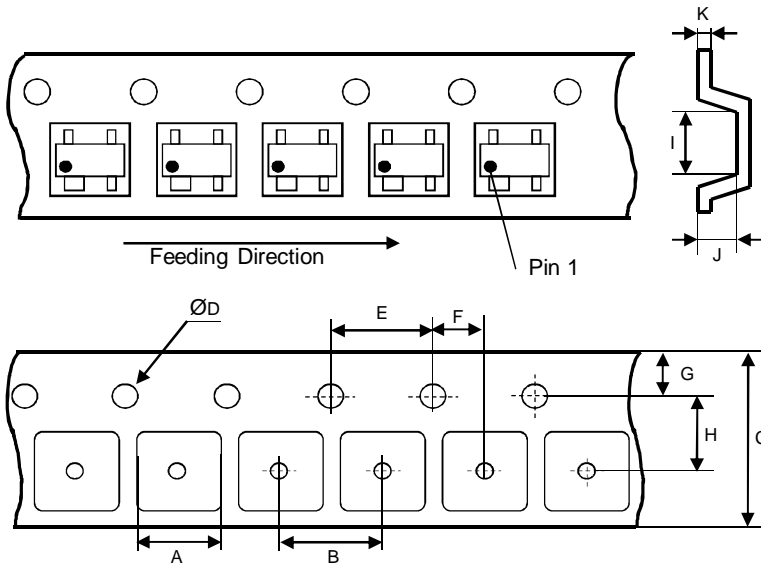

A	<b>3.15 ± 0.15</b>	mm
B	<b>4.00 ± 0.10</b>	mm
C	<b>8.00 ± 0.20</b>	mm
D	<b>1.55 ± 0.05</b>	mm
E	<b>4.00 ± 0.10</b>	mm
F	<b>2.00 ± 0.05</b>	mm
G	<b>1.75 ± 0.10</b>	mm
H	<b>3.50 ± 0.05</b>	mm
I	<b>3.25 ± 0.15</b>	mm
J	<b>1.35 ± 0.15</b>	mm
K	<b>0.25 ± 0.02</b>	mm

## J Reel:

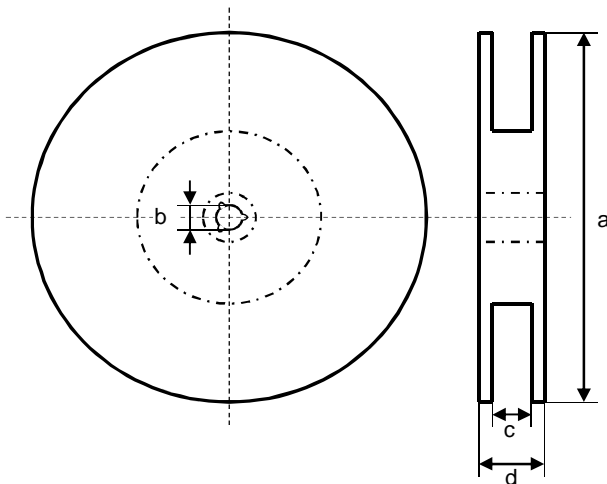

a	<b>178.0 ± 2.0</b>	mm
b	<b>13.0 ± 0.8</b>	mm
c	<b>10.0 ± 1.5</b>	mm
d	<b>12.5 ± 2.0</b>	mm

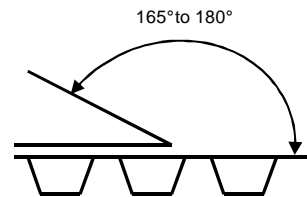

Quantity per Reel: 3000

General Release:	Customer			
	Date	Signature		
Checked	Würth Elektronik			
	Approved	JB	Version 1	2010-01-27
		Name	Modification	Date

This electronic component has been designed and developed for usage in general electronic equipment. Before incorporating this component into any equipment where higher safety and reliability is especially required or if there is the possibility of direct damage or injury to human body, for example in the range of aerospace, aviation, nuclear control, submarine, transportation, (automotive control, train control, ship control), transportation signal, disaster prevention, medical, public information network etc, Würth Elektronik eiSos GmbH must be informed before the design-in stage. In addition, sufficient reliability evaluation checks for safety must be performed on every electronic component which is used in electrical circuits that require high safety and reliability functions or performance.

### Würth Elektronik eiSos GmbH & Co. KG

D-74638 Waldenburg · Max-Eyth-Strasse 1 · Germany · Phone (+49) (0) 7942 - 945 - 0 · Fax (+49) (0) 7942 - 945 - 400

<http://www.we-online.com>