

Super-mini Signal Conditioners Mini-M Series

UNIVERSAL TRANSMITTER

(PC programmable; Modbus-RTU communication)

Functions & Features

- Accepts direct inputs from various sensors and provides a standard process signal
- I/O types and calibration ranges are fully programmable via a PC
- Linearization up to 100 points can be programmed for DC and potentiometer inputs
- Isolation between input - output - RS-485 - power
- CE marking

Typical Applications

- Signal conversion between control room and field instrumentation with isolation
- Ideal for use as a fast solution, multifunctional spare part

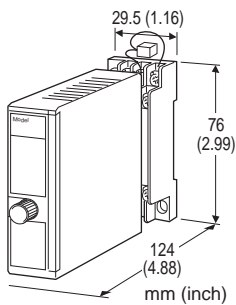

MODEL: M2XUM-[1][2]-[3][4]

ORDERING INFORMATION

- Code number: M2XUM-[1][2]-[3][4]
Specify a code from below for each [1] through [4].
(e.g. M2XUM-00-M2/CE/Q)
- Specify the specification for option code /Q
(e.g. /C01/S01)

Non-specified orders will be shipped at default factory settings (M2XUM-00: 4 - 20 mA input/4 - 20 mA output). However, the power suffix code **must** be specified.

If you specify full code numbers without specific calibration ranges, default settings will be used.

Note: Must be used with its socket. NOT installable to a multi-unit installation base. (e.g. model: M2BS-16)

[1] INPUT

0: User-calibrated (Factory default: 4 - 20 mA DC)

If the unit is to be factory-calibrated to a specific

input type, please select from the following:

Current

Z1: Range 0 - 50 mA DC (Input resistance 100 Ω)

Voltage

S1: Range -1 - +1 V DC (Input resistance 1 MΩ min.)

S2: Range -10 - +10 V DC (Input resistance 1 MΩ min.)

Thermocouple

T1: (PR) (Usable Range 0 to 1760°C, 32 to 3200°F)

T2: K (CA) (Usable range -270 to +1370°C, -454 to +2498°F)

T3: E (CRC) (Usable range -270 to +1000°C, -454 to +1832°F)

T4: J (IC) (Usable range -210 to +1200°C, -346 to +2192°F)

T5: T (CC) (Usable range -270 to +400°C, -454 to +752°F)

T6: B (RH) (Usable range 0 to 1820°C, 32 to 3308°F)

T7: R (Usable range -50 to +1760°C, -58 to +3200°F)

T8: S (Usable range -50 to +1760°C, -58 to +3200°F)

T9: C(WRe 5-26) (Usable range 0 to 2315°C, 32 to 4199°F)

TN: N (Usable range -270 to +1300°C, -454 to +2372°F)

TU: U (Usable range -200 to +400°C, -328 to +752°F)

TL: L (Usable range -200 to +900°C, -328 to +1652°F)

TP: Platinel II(Usable range 0 to 1395°C, 32 to 2543°F)

T0: Specify (Please provide an emf table.)

RTD

(2- or 3-wire)

R1: JPt 100 (JIS'89)

(Usable range: -200 to +500°C, -328 to +932°F)

R3: Pt 100 (JIS'89)

(Usable range: -200 to +850°C, -328 to +1562°F)

R4: Pt 100 (JIS'97, IEC)

(Usable range: -200 to +850°C, -328 to +1562°F)

R5: Pt 50 Ω (JIS'81)

(Usable range: -200 to +649 °C, -328 to +1200°F)

R6: Ni 508.4 Ω

(Usable range: -50 to +200°C, -58 to +392°F)

R7: Pt 1000

(Usable range: -200 to +200°C, -328 to +392°F)

R8: Ni 100 (100 Ω @ 0°C)

(Usable range: -50 to +200°C, -58 to +392°F)

R9: Cu 10 (10 Ω @25°C)

(Usable range: -50 to +200°C, -58 to +392°F)

R0: Specify (Please provide a resistance table.)

Potentiometer

M: Total resistance 100 Ω - 10 kΩ

[2] OUTPUT

0: User-calibrated (Factory default: 4 - 20 mA DC)

If the unit is to be factory-calibrated to a specific output type, please select from the following:

Current

Z1: Range 0 - 20 mA DC

Voltage

V1: Range -2.5 - +2.5 V DC

V2: Range -10 – +10 V DC

[3] POWER INPUT

AC Power

M2: 100 – 240 V AC (Operational voltage range 85 – 264 V, 47 – 66 Hz)

DC Power

R: 24 V DC

(Operational voltage range 24 V ±10 %, ripple 10 %p-p max.)

P: 110 V DC

(Operational voltage range 85 – 150 V, ripple 10 %p-p max.)

[4] OPTIONS (multiple selections)

Standards & Approvals (must be specified)

/N: Without CE

/CE: CE marking

Other Options

blank: none

/Q: Option other than the above (specify the specification)

SPECIFICATIONS OF OPTION: Q (multiple selections)

COATING (For the detail, refer to M-System's web site.)

/C01: Silicone coating

/C02: Polyurethane coating

/C03: Rubber coating

TERMINAL SCREW MATERIAL

/S01: Stainless steel

RELATED PRODUCTS

• JX configurator connection kit (model: JXCON)

For configuration JXCON is necessary.

GENERAL SPECIFICATIONS

Construction: Plug-in

Connection: M3 screw terminals (torque 0.8 N·m)

Housing material: Flame-resistant resin (black)

Isolation: Input to output to RS-485 to power

Overrange output: Approx. -15 to +115 %

(Negative current output is not provided.)

Manual zero adjustments: -5 to +5 %

(factory setting: 0 %)

Manual span adjustments: 95 to 105 %

(factory setting: 100 %)

Programming: PC programmable features include:

- T/C and RTD type and temp. range
- Input and output ranges
- Zero and span adjustments
- Simulated output
- User's linearization table (max. 100 points, specified within -15 – +115 % for both input and output)

· User's TC/RTD table

Burnout (T/C, RTD and Pot.): Upscale standard; downscale or no burnout options are PC programmable

Linearization (T/C, RTD input): Standard tables stored in memory

Cold junction compensation (T/C): CJC sensor (included) to be attached to the input terminals

Status indicator LED: Flashing patterns indicate different operating status of the transmitter.

Configurator connection: 2.5 dia. miniature jack; RS-232-C level

MODBUS COMMUNICATION

Standard: Conforms to RS-485, EIA

Transmission distance: 500 meters max.

Baud rate: 38.4 kbps max.

Communication: Half-duplex, asynchronous, no procedure

Protocol: Modbus RTU

Transmission media: Shielded twisted-pair cable (CPEV-S 0.9 dia.)

INPUT SPECIFICATIONS

■ **DC Current:** Shunt resistor attached to the input terminals (0.5 W)

Operational range: 0 – 70 mA DC with 100 Ω, 0.5 W

Input range: 0 – 50 mA DC

Minimum span: 2 mA

Offset: Lower range can be any specific value within the input range provided that the minimum span is maintained. If not specified, the input range is 4 – 20 mA DC.

■ DC Voltage

Operational range: -11.5 – +11.5 V DC

Input range: -10 – +10 V DC

Minimum span: 10 mV for S1; 100 mV for S2

Offset: Lower range can be any specific value within the input range provided that the minimum span is maintained. If not specified, the input range is shown below.

S1: 0 – 100 mV DC

S2: 1 – 5 V DC

■ Thermocouple

For T/C types K, E, T, B, R, S or N, the accuracy in the temperature ranges near the lower limit may be out of the described value. Consult M-System for more detail.

Input resistance: 1 MΩ min.

Burnout sensing: 45 nA ±10 %

Offset: Lower range can be any specific value within the input range provided that the minimum span is maintained. If not specified, the input range is shown below.

T1 PR : 0 – 1600°C

T2 K : 0 – 1000°C

T3 E : 0 – 500°C

T4 J: 0 - 500°C
 T5 T: 0 - 300°C
 T6 B: 0 - 1800°C
 T7 R: 0 - 1600°C
 T8 S: 0 - 1600°C
 T9 C (WRe 5 - 26) : 0 - 2000°C
 TN N : 0 - 1000°C
 TU U : 0 - 300°C
 TL L : 0 - 500°C
 TP Platinel II : 0 - 1200°C

■ RTD: 2- or 3-wire RTD

Maximum leadwire resistance: 200 Ω per wire (3 -wire)

Sensing current: ≤ 1.0 mA

If not specified, the input range is shown below.

R1: JPt 100 0 - 100°C
 R3: Pt 100 0 - 100°C
 R4: Pt 100 0 - 100°C
 R5: Pt 50 Ω 0 - 200°C
 R6: Ni 508.4 Ω 0 - 100°C
 R7: Pt 1000 0 - 100°C
 R8: Ni 100 0 - 100°C
 R9: Cu 10 0 - 100°C

•Potentiometer: 100 Ω - 10 kΩ

Minimum span:

(Range) 0 - 100 Ω : 2.5 Ω

0 - 300 Ω : 3.0 Ω

0 - 1000 Ω : 10 Ω

0 - 10 kΩ : 10 Ω

Excitation: ≤ 0.5 V DC at 1000 Ω

If not specified, the input range is 0 - 1000 Ω.

OUTPUT SPECIFICATIONS

■ DC Current

Operational range: 0 - 24 mA DC

Output range: 0 - 20 mA DC

Minimum span: 1 mA

Offset: Lower range can be any specific value within the output range provided that the minimum span is maintained.

Load resistance: Output drive 15 V max.

(e.g. 4 - 20 mA: 750 Ω [15 V / 20 mA])

If not specified, the output range is 4 - 20 mA DC.

■ DC Voltage

Code V1 (narrow spans)

Operational range: -3 - +3 V DC

Output range: -2.5 - +2.5 V DC

Minimum span: 250 mV

Code V2 (wide spans)

Operational range: -11.5 - +11.5 V DC

Output range: -10 - +10 V DC

Minimum span: 1 V

Offset: Lower range can be any specific value within the

output range provided that the minimum span is maintained.

Load resistance: Output drive 1 mA max.

(e.g. 1 - 5 V: 5000 Ω [5 V / 1 mA])

If not specified, the output range is shown below.

V1: 0 - 1 V DC

V2: 1 - 5 V DC

INSTALLATION

Power Consumption

•AC Power input: Approx. 6 VA

•DC power input: Approx. 3 W

Operating temperature: -30 to +60°C (-22 to +140°F)

Operating humidity: 30 to 90 %RH (non-condensing)

Mounting: Surface or DIN rail

Weight: 120 g (0.26 lbs)

PERFORMANCE

Accuracy: Input accuracy + output accuracy

Input accuracy (% of input range)

Inversely proportional to span.

(DC) -1 - +1 V : ±0.02

-10 - +10 V : ±0.02

0 - 50 mA : ±0.02

Except the input resistor error.

(T/C) (PR) : ±0.08

K (CA) : ±0.02

E (CRC) : ±0.02

J (IC) : ±0.04

T (CC) : ±0.06

B (RH) : ±0.12

R : ±0.08

S : ±0.08

C (WRe 5 - 26) : ±0.04

N : ±0.04

U : ±0.04

L : ±0.04

P (Platinel II) : ±0.04

(RTD) JPt 100 (JIS '89) : ±0.04

Pt 100 (JIS '89) : ±0.03

Pt 100 (JIS '97, IEC) : ±0.03

Pt 50 Ω (JIS '81) : ±0.04

Ni 508.4 Ω : ±0.05

Pt 1000 : ±0.08

Ni 100 : ±0.14

Cu 10 : ±0.6

(Pot.) 0 - 100 Ω : ±0.08

0 - 300 Ω : ±0.04

0 - 1000 Ω : ±0.04

0 - 10 kΩ : ±0.04

Output accuracy: ±0.02 % of output range

Inversely proportional to span.

Cold junction compensation error:

±0.4°C or ±0.7°F (at 20°C ±10°C or 68°F ±18°F)

Temp. coefficient

(at -5 to +55°C [23 to 131°F] of I/O range)

Input: ±0.016 %/°C (±0.009 %/°F) with current

±0.004 %/°C (±0.002 %/°F) with voltage

±0.004 %/°C (±0.002 %/°F) with T/C

±0.004 %/°C (±0.002 %/°F) with RTD

±0.004 %/°C (±0.002 %/°F) with Pot.

Output: ±0.013 %/°C (±0.007 %/°F)

Response time:

≤ 0.5 sec.(0 - 90 %) with current

≤ 0.5 sec.(0 - 90 %) with voltage

≤ 1.5 sec.(0 - 90 %) with T/C

≤ 0.9 sec.(0 - 90 %) with RTD

≤ 0.9 sec. (0 - 90 %) with Pot.

Burnout response: ≤ 10 sec.

Line voltage effect: ±0.1 % over voltage range

Insulation resistance: ≥ 100 MΩ with 500 V DC

Dielectric strength: 2000 V AC @1 minute (input to output to RS-485 to power to ground)

CALCULATION EXAMPLES OF OVERALL ACCURACY

[Example] Input Type -10 - +10 V, Input Range 1 - 5 V,

Output Type 0 - 20 mA, Output Range 0 - 10 mA

Max. Input Range (20 V) ÷ Span (4 V) × 0.02 % = 0.1 %

Max. Output Range (20 mA) ÷ Span (10 mA) × 0.02 % =

0.04 %

Overall accuracy = 0.1 + 0.04 = ±0.14 %

STANDARDS & APPROVALS

CE conformity:

EMC Directive (2004/108/EC)

EMI EN 61000-6-4: 2007

EMS EN 61000-6-2: 2005

Low Voltage Directive (2006/95/EC)

EN 61010-1: 2001

Installation Category II

Pollution Degree 2

Input or output to power: Reinforced insulation (300 V)

Input to output: Basic insulation (300 V)

EXTERNAL VIEW

FRONT VIEW (with cover open)

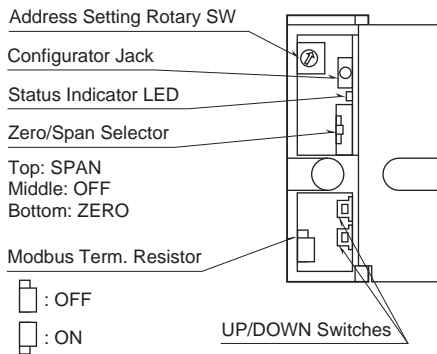

The front cover cannot be opened to 180 deg. when flush with neighboring units.

RIGHT SIDE VIEW

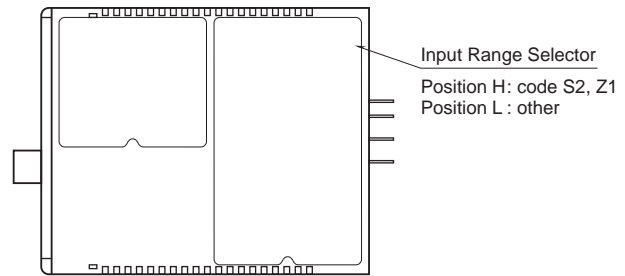

Refer to the instruction manual for detailed procedures.

DIMENSIONS unit: mm (inch)

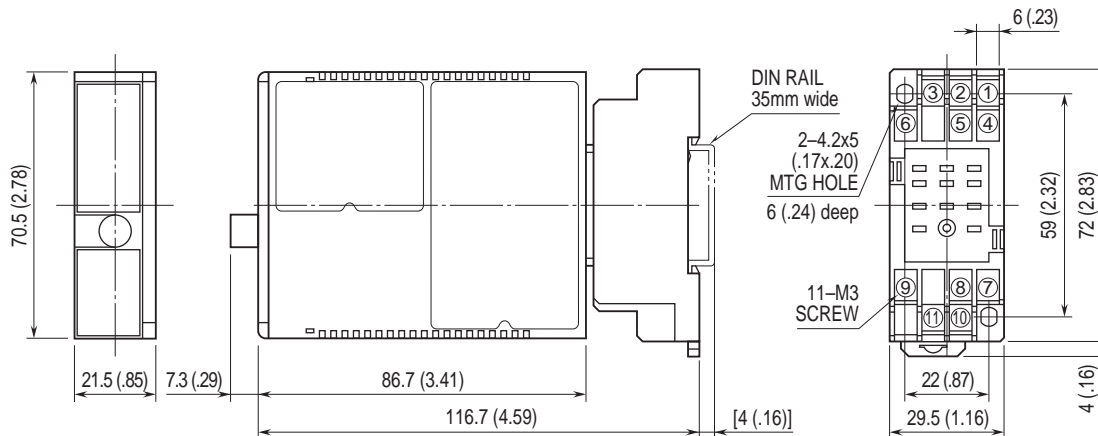

• When mounting, no extra space is needed between units.

TERMINAL ASSIGNMENTS unit: mm (inch)

Use the input resistor (model: REM2) for a DC current input, and the CJC sensor (model: CJM) for a thermocouple input, both included in the package.

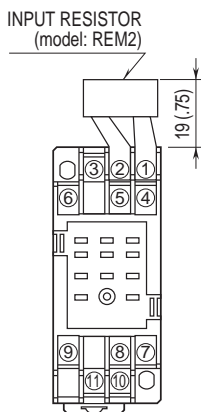

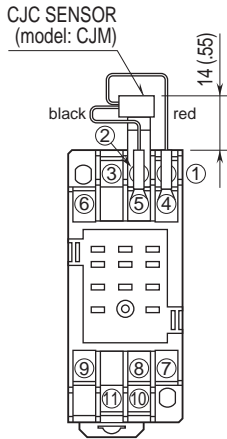

SCHEMATIC CIRCUITRY & CONNECTION DIAGRAM

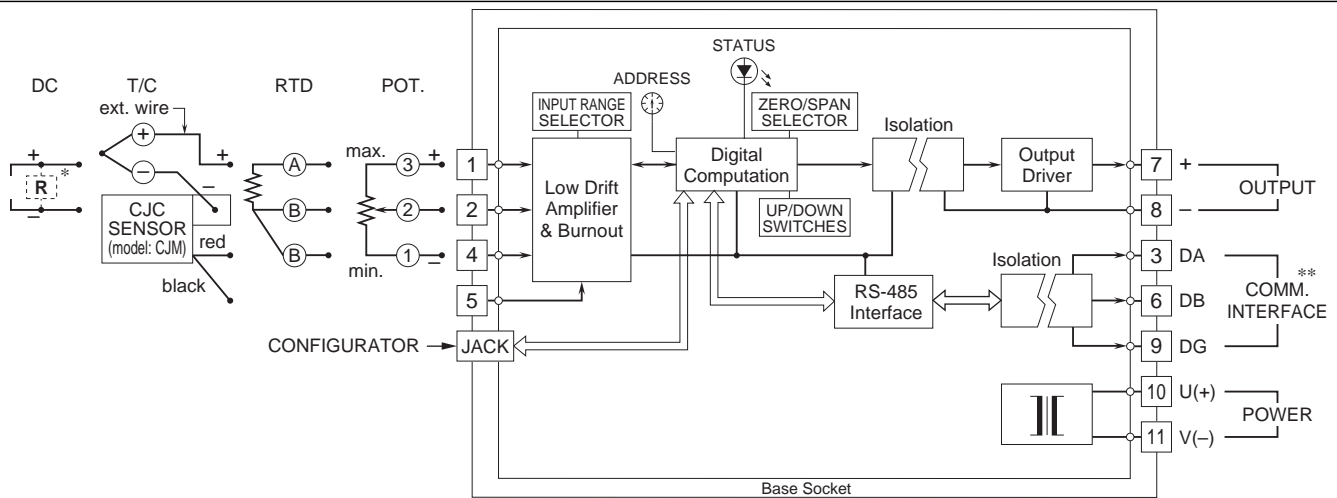

* Input shunt resistor attached for current input.
 **When the module is at the end of RS-485 transmission line, turn on the Modbus terminating resistor located behind the front cover, off when it is not.

SYSTEM CONFIGURATION EXAMPLES

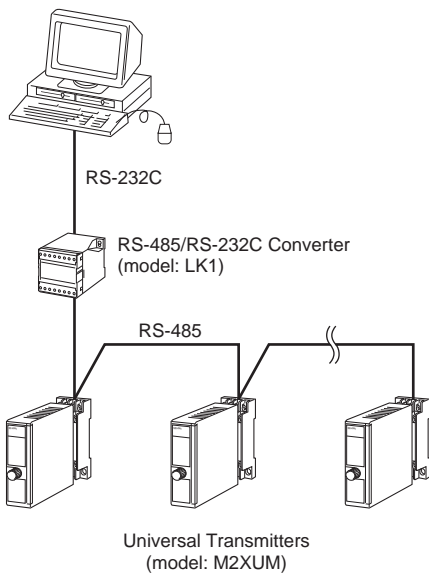

MODBUS COMMUNICATION PARAMETERS

Refer to the instruction manual for the details about Modbus communication.

■ COMMUNICATION PARAMETERS

PARAMETER	SPECIFICATIONS	DEFAULT	MODIFICATION
Data Mode	RTU	RTU	Not modifiable
Baud Rate	9600/19200/38400 bps	38400 bps	JXCON Software
Parity	None/Odd/Even	Odd	JXCON Software
Bit Length	8	8	Not modifiable
Stop Bit	1	1	Not modifiable
Node Address	1 to 247	1	Hardware Rotary SW for 1 through 16, JXCON Software for 16 through 247 (Rotary SW set to 0).
Floating Point Data	Normal/Swapped	Normal	JXCON Software
Physical Layer	RS-485	RS-485	Not modifiable



Specifications are subject to change without notice.