

## Super-mini Signal Conditioners Mini-M Series

### DIVIDER

#### Functions & Features

- Receives two DC inputs and provides an output proportional to the division of the inputs

#### Typical Applications

- Air-fuel ratio control
- Ratio control in mixing two kinds of liquid

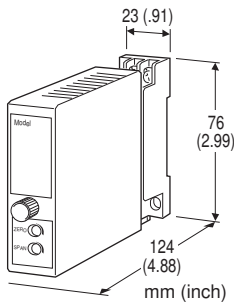

## MODEL: M2DIS-[1][2][3]-[4][5]

### ORDERING INFORMATION

- Code number: M2DIS-[1][2][3]-[4][5]
- Specify a code from below for each [1] through [5].  
(e.g. M2DIS-6AA-M2/CE/Q)
- Ratios (e.g.  $K_1 = 0.80$ ,  $K_2 = 2.00$ )
- Special input and output ranges (For codes Z&0)
- Specify the specification for option code /Q  
(e.g. /C01/S01)

### [1] INPUT 1

#### Current

- A: 4 - 20 mA DC (Input resistance 250  $\Omega$ )
- A1: 4 - 20 mA DC (Input resistance 50  $\Omega$ )
- B: 2 - 10 mA DC (Input resistance 500  $\Omega$ )
- C: 1 - 5 mA DC (Input resistance 1000  $\Omega$ )
- D: 0 - 20 mA DC (Input resistance 50  $\Omega$ )
- E: 0 - 16 mA DC (Input resistance 62.5  $\Omega$ )
- F: 0 - 10 mA DC (Input resistance 100  $\Omega$ )
- G: 0 - 1 mA DC (Input resistance 1000  $\Omega$ )
- H: 10 - 50 mA DC (Input resistance 100  $\Omega$ )
- J: 0 - 10  $\mu$ A DC (Input resistance 1000  $\Omega$ )
- K: 0 - 100  $\mu$ A DC (Input resistance 1000  $\Omega$ )
- GW: -1 - +1 mA DC (Input resistance 1000  $\Omega$ )
- FW: -10 - +10 mA DC (Input resistance 100  $\Omega$ )
- Z: Specify current (See INPUT SPECIFICATIONS)

#### Voltage

- 1: 0 - 10 mV DC (Input resistance 10 k $\Omega$  min.)

- 2: 0 - 100 mV DC (Input resistance 100 k $\Omega$  min.)
- 3: 0 - 1 V DC (Input resistance 1 M $\Omega$  min.)
- 4: 0 - 10 V DC (Input resistance 1 M $\Omega$  min.)
- 5: 0 - 5 V DC (Input resistance 1 M $\Omega$  min.)
- 6: 1 - 5 V DC (Input resistance 1 M $\Omega$  min.)
- 4W: -10 - +10 V DC (Input resistance 1 M $\Omega$  min.)
- 5W: -5 - +5 V DC (Input resistance 1 M $\Omega$  min.)
- 0: Specify voltage (See INPUT SPECIFICATIONS)

### [2] INPUT 2

Same range availability as Input 1

### [3] OUTPUT

#### Current

- A: 4 - 20 mA DC (Load resistance 750  $\Omega$  max.)
- B: 2 - 10 mA DC (Load resistance 1500  $\Omega$  max.)
- C: 1 - 5 mA DC (Load resistance 3000  $\Omega$  max.)
- D: 0 - 20 mA DC (Load resistance 750  $\Omega$  max.)
- E: 0 - 16 mA DC (Load resistance 900  $\Omega$  max.)
- F: 0 - 10 mA DC (Load resistance 1500  $\Omega$  max.)
- G: 0 - 1 mA DC (Load resistance 15 k $\Omega$  max.)
- Z: Specify current (See OUTPUT SPECIFICATIONS)

#### Voltage

- 1: 0 - 10 mV DC (Load resistance 10 k $\Omega$  min.)
- 2: 0 - 100 mV DC (Load resistance 100 k $\Omega$  min.)
- 3: 0 - 1 V DC (Load resistance 1000  $\Omega$  min.)
- 4: 0 - 10 V DC (Load resistance 10 k $\Omega$  min.)
- 5: 0 - 5 V DC (Load resistance 5000  $\Omega$  min.)
- 6: 1 - 5 V DC (Load resistance 5000  $\Omega$  min.)
- 4W: -10 - +10 V DC (Load resistance 10 k $\Omega$  min.)
- 5W: -5 - +5 V DC (Load resistance 5000  $\Omega$  min.)
- 0: Specify voltage (See OUTPUT SPECIFICATIONS)

### [4] POWER INPUT

#### AC Power

- M2: 100 - 240 V AC (Operational voltage range 85 - 264 V, 47 - 66 Hz)  
(90 - 264 V for UL)

#### DC Power

- R: 24 V DC  
(Operational voltage range 24 V  $\pm$ 10 %, ripple 10 %p-p max.)
- R2: 11 - 27 V DC  
(Operational voltage range 11 - 27 V, ripple 10 %p-p max.)  
(Select 'N' for 'Standards & Approvals' code.)
- P: 110 V DC  
(Operational voltage range 85 - 150 V, ripple 10 %p-p max.)  
(110 V  $\pm$ 10 % for UL)

**[5] OPTIONS (multiple selections)****Standards & Approvals (must be specified)**

/N: Without CE or UL

/CE: CE marking

/UL: UL approval, CE marking

**Other Options**

blank: none

/Q: Option other than the above (specify the specification)

(UL not available)

**SPECIFICATIONS OF OPTION: Q (multiple selections)****COATING (For the detail, refer to M-System's web site.)**

/C01: Silicone coating

/C02: Polyurethane coating

/C03: Rubber coating

**TERMINAL SCREW MATERIAL**

/S01: Stainless steel

**GENERAL SPECIFICATIONS****Construction:** Plug-in**Connection:** M3 screw terminals (torque 0.8 N·m)**Screw terminal:** Chromated steel (standard) or stainless steel**Housing material:** Flame-resistant resin (black)**Isolation:** Input 1 or input 2 to output to power  
(Negative sides of the input 1 and 2 must be of the same potential.)**Overrange output:** 0 to 120 % (approx.) at 1 - 5 V**Zero adjustment:** -5 to +5 % (front)**Span adjustment:** 95 to 105 % (front)**Equation:** Output =  $(K_1 \times \text{Input 1}) \div (K_2 \times \text{Input 2})$  $K_1, K_2$ : 0.10 to 2.00 specified when ordering  
 $(0.40 \leq (K_1 \div K_2) \leq 2.00)$ 

Input 1, Input 2: 0 to 120 %

Forcibly limited to 0 % and 120 % respectively when the signal is out of range.

**INPUT SPECIFICATIONS**■ **DC Current:** Input resistor incorporated

Specify input resistance value for code Z.

 $(R \leq 0.25 \text{ W} \div [\text{F.S. Current}]^2)$ ■ **DC Voltage:** -300 - +300 V DC**Minimum span:** 10 mV**Offset:** Max. 1.5 times span**Input resistance**Span 10 - 100 mV :  $\geq 10 \text{ k}\Omega$ Span 0.1 - 1 V :  $\geq 100 \text{ k}\Omega$ Span  $\geq 1 \text{ V}$  :  $\geq 1 \text{ M}\Omega$ **OUTPUT SPECIFICATIONS**■ **DC Current:** 0 - 20 mA DC**Minimum span:** 1 mA**Offset:** Max. 1.5 times span**Load resistance:** Output drive 15 V max.■ **DC Voltage:** -10 - +12 V DC**Minimum span:** 5 mV**Offset:** Max. 1.5 times span**Load resistance:** Output drive 1 mA max.; at  $\geq 0.5 \text{ V}$ **INSTALLATION****Power Consumption**• **AC:**

Approx. 3 VA at 100 V

Approx. 4 VA at 200 V

Approx. 5 VA at 264 V

• **DC:** Approx. 3 W**Operating temperature:** -5 to +55°C (23 to 131°F)**Operating humidity:** 30 to 90 %RH (non-condensing)**Mounting:** Surface or DIN rail**Weight:** 150 g (0.33 lb)**PERFORMANCE in percentage of span****Accuracy:**  $\pm 1.0 \%$  at  $[K_1 \div K_2 \leq 1]$  $\pm 2.0 \%$  at  $[K_1 \div K_2 > 1]$ at Input 2  $\geq 20 \%$ **Temp. coefficient:**  $\pm 0.02 \%$  /°C ( $\pm 0.01 \%$  /°F) at Input 2  $\geq 20 \%$ **Response time:**  $\leq 0.5 \text{ sec.}$  (0 - 90 %)**Line voltage effect:**  $\pm 0.1 \%$  over voltage range**Insulation resistance:**  $\geq 100 \text{ M}\Omega$  with 500 V DC**Dielectric strength:** 2000 V AC @1 minute (input 1 or input 2 to output to power to ground)**STANDARDS & APPROVALS****CE conformity:**

EMC Directive (2004/108/EC)

EMI EN 61000-6-4: 2007/A1: 2011

EMS EN 61000-6-2: 2005

Low Voltage Directive (2006/95/EC)

EN 61010-1: 2010

Installation Category II

Pollution Degree 2

Input 1 or input 2 or output to power input:

Reinforced insulation (300 V)

Input 1 or input 2 to output: Basic insulation (300 V)

**Approval:**

UL/C-UL nonincendive Class I, Division 2,

Groups A, B, C, and D

(ANSI/ISA-12.12.01:2011, CAN/CSA-C22.2 No.213:1987)

UL/C-UL general safety requirements

(UL 61010B-1:2003, CAN/CSA-C22.2 No.61010-1:1992)

## DIMENSIONS unit: mm (inch)

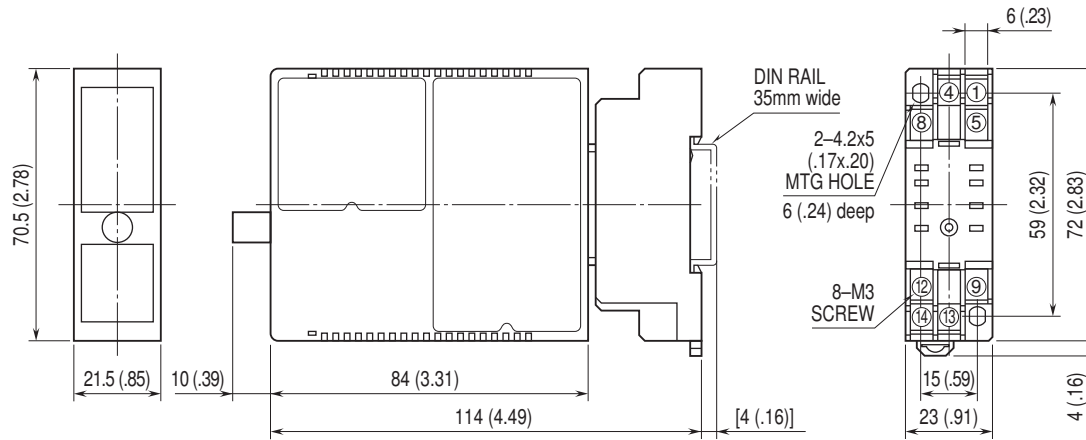

• When mounting, no extra space is needed between units.

## SCHEMATIC CIRCUITRY & CONNECTION DIAGRAM

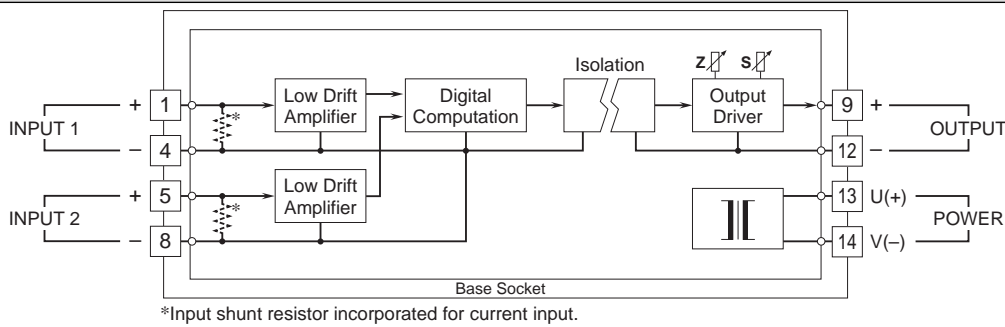

Specifications are subject to change without notice.