

Super-mini Signal Conditioners Mini-M Series

RAMP BUFFER

Functions & Features

- Limiting the rate of change of the output once the rate of the input exceeds the preset value
- Rate-of-change adjustable up to 40 seconds
- CE marking
- UL approval

Typical Applications

- Reducing the rate of change caused by a step change or spikes on the input signal
- Protecting equipment that cannot withstand rapidly changing process variables

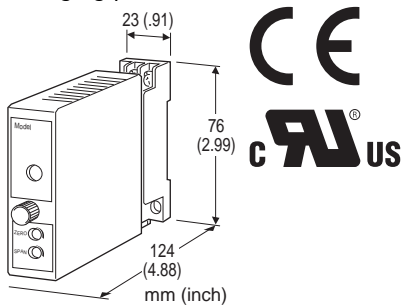

MODEL: M2CRS-[1][2]-[3][4]

ORDERING INFORMATION

- Code number: M2CRS-[1][2]-[3][4]
Specify a code from below for each [1] through [4].
(e.g. M2CRS-6A-M2/CE/Q)
- Special input and output ranges (For codes Z&O)
- Specify the specification for option code /Q
(e.g. /C01/S01)

[1] INPUT

Current

- A:** 4 - 20 mA DC (Input resistance 250 Ω)
- A1:** 4 - 20 mA DC (Input resistance 50 Ω)
- B:** 2 - 10 mA DC (Input resistance 500 Ω)
- C:** 1 - 5 mA DC (Input resistance 1000 Ω)
- D:** 0 - 20 mA DC (Input resistance 50 Ω)
- E:** 0 - 16 mA DC (Input resistance 62.5 Ω)
- F:** 0 - 10 mA DC (Input resistance 100 Ω)
- G:** 0 - 1 mA DC (Input resistance 1000 Ω)
- H:** 10 - 50 mA DC (Input resistance 100 Ω)
- J:** 0 - 10 μA DC (Input resistance 1000 Ω)
- K:** 0 - 100 μA DC (Input resistance 1000 Ω)
- GW:** -1 - +1 mA DC (Input resistance 1000 Ω)
- FW:** -10 - +10 mA DC (Input resistance 100 Ω)

Z: Specify current (See INPUT SPECIFICATIONS)

Voltage

- 1:** 0 - 10 mV DC (Input resistance 10 kΩ min.)
- 15:** 0 - 50 mV DC (Input resistance 10 kΩ min.)
- 16:** 0 - 60 mV DC (Input resistance 10 kΩ min.)
- 2:** 0 - 100 mV DC (Input resistance 100 kΩ min.)
- 3:** 0 - 1 V DC (Input resistance 1 MΩ min.)
- 4:** 0 - 10 V DC (Input resistance 1 MΩ min.)
- 5:** 0 - 5 V DC (Input resistance 1 MΩ min.)
- 6:** 1 - 5 V DC (Input resistance 1 MΩ min.)
- 4W:** -10 - +10 V DC (Input resistance 1 MΩ min.)
- 5W:** -5 - +5 V DC (Input resistance 1 MΩ min.)
- 0:** Specify voltage (See INPUT SPECIFICATIONS)

[2] OUTPUT

Current

- A:** 4 - 20 mA DC (Load resistance 750 Ω max.)
- B:** 2 - 10 mA DC (Load resistance 1500 Ω max.)
- C:** 1 - 5 mA DC (Load resistance 3000 Ω max.)
- D:** 0 - 20 mA DC (Load resistance 750 Ω max.)
- E:** 0 - 16 mA DC (Load resistance 900 Ω max.)
- F:** 0 - 10 mA DC (Load resistance 1500 Ω max.)
- G:** 0 - 1 mA DC (Load resistance 15 kΩ max.)
- Z:** Specify current (See OUTPUT SPECIFICATIONS)

Voltage

- 1:** 0 - 10 mV DC (Load resistance 10 kΩ min.)
- 2:** 0 - 100 mV DC (Load resistance 100 kΩ min.)
- 3:** 0 - 1 V DC (Load resistance 1000 Ω min.)
- 4:** 0 - 10 V DC (Load resistance 10 kΩ min.)
- 5:** 0 - 5 V DC (Load resistance 5000 Ω min.)
- 6:** 1 - 5 V DC (Load resistance 5000 Ω min.)
- 4W:** -10 - +10 V DC (Load resistance 10 kΩ min.)
- 5W:** -5 - +5 V DC (Load resistance 5000 Ω min.)
- 0:** Specify voltage (See OUTPUT SPECIFICATIONS)

[3] POWER INPUT

AC Power

M: 85 - 264 V AC (Operational voltage range 85 - 264 V, 47 - 66 Hz)

(Select '/N' for 'Standards & Approvals' code.)

M2: 100 - 240 V AC (Operational voltage range 85 - 264 V, 47 - 66 Hz)

(90 - 264 V for UL)

DC Power

R: 24 V DC

(Operational voltage range 24 V ±10 %, ripple 10 %p-p max.)

R2: 11 - 27 V DC

(Operational voltage range 11 - 27 V, ripple 10 %p-p max.)

(Select '/N' for 'Standards & Approvals' code.)

P: 110 V DC

(Operational voltage range 85 - 150 V, ripple 10 %p-p max.)

(110 V \pm 10 % for UL)

[4] OPTIONS (multiple selections)

STANDARDS & APPROVALS (must be specified)

/N: Without CE or UL

/CE: CE marking

/UL: UL approval (CE marking)

OTHER OPTIONS

blank: none

/Q: Option other than the above (specify the specification)
(UL not available)

SPECIFICATIONS OF OPTION: Q (multiple selections)

COATING (For the detail, refer to M-System's web site.)

/C01: Silicone coating

/C02: Polyurethane coating

/C03: Rubber coating

TERMINAL SCREW MATERIAL

/S01: Stainless steel

GENERAL SPECIFICATIONS

Construction: Plug-in

Connection: M3 screw terminals (torque 0.8 N·m)

Housing material: Flame-resistant resin (black)

Isolation: Input to output to power

Overrange output: Approx. -10 to +120 % at 1 - 5 V

Rate-of-change adjustment: 260°-turn screwdriver adjustment (front)

Rate-of-change adjustment range: approx. 0.5 to 40 sec. (0 - 100%; factory set to MIN.)

Zero adjustment: -5 to +5 % (front)

Span adjustment: 95 to 105 % (front)

INPUT SPECIFICATIONS

• DC Current:

Shunt resistor attached to the input terminals (0.5 W)

Specify input resistance value for code Z.

• DC Voltage: -300 - +300 V DC

Minimum span: 3 mV

Offset: Max. 1.5 times span

Input resistance

Span 3 - 10 mV : \geq 10 k Ω

Span 10 - 100 mV : \geq 10 k Ω

Span 0.1 - 1 V : \geq 100 k Ω

Span \geq 1 V : \geq 1 M Ω

OUTPUT SPECIFICATIONS

• DC Current: 0 - 20 mA DC

Minimum span: 1 mA

Offset: Max. 1.5 times span

Load resistance: Output drive 15 V max.

• DC Voltage: -10 - +12 V DC

Minimum span: 5 mV

Offset: Max. 1.5 times span

Load resistance: Output drive 1 mA max.; at \geq 0.5 V

INSTALLATION

Power Consumption

• AC Power input:

Approx. 3 VA at 100 V

Approx. 4 VA at 200 V

Approx. 5 VA at 264 V

• DC Power input: Approx. 3 W

Operating temperature: -5 to +55°C (23 to 131°F)

Operating humidity: 30 to 90 %RH (non-condensing)

Mounting: Surface or DIN rail

Weight: 150 g (0.33 lbs)

PERFORMANCE in percentage of span

Accuracy: \pm 0.2 %

Temp. coefficient: \pm 0.015 %/°C (\pm 0.008 %/°F)

Line voltage effect: \pm 0.1 % over voltage range

Insulation resistance: \geq 100 M Ω with 500 V DC

Dielectric strength: 2000 V AC @1 minute (input to output to power to ground)

STANDARDS & APPROVALS

CE conformity:

EMC Directive (2004/108/EC)

EN 61000-6-4 (EMI)

EN 61000-6-2 (EMS)

Low Voltage Directive (2006/95/EC)

EN 61010-1

Installation Category II

Pollution Degree 2

Max. operating voltage 300 V

Input or output to power: Reinforced insulation

Input to output: Basic insulation

Approval:

UL/C-UL nonincendive Class I, Division 2,

Groups A, B, C, and D hazardous locations
(UL 1604, CAN/CSA-C22.2 No.213)

UL/C-UL general safety requirements

(UL 61010B-1, CAN/CSA-C22.2 No.1010-1)

EXTERNAL VIEW

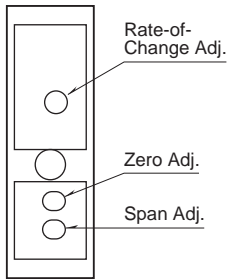

DIMENSIONS unit: mm (inch)

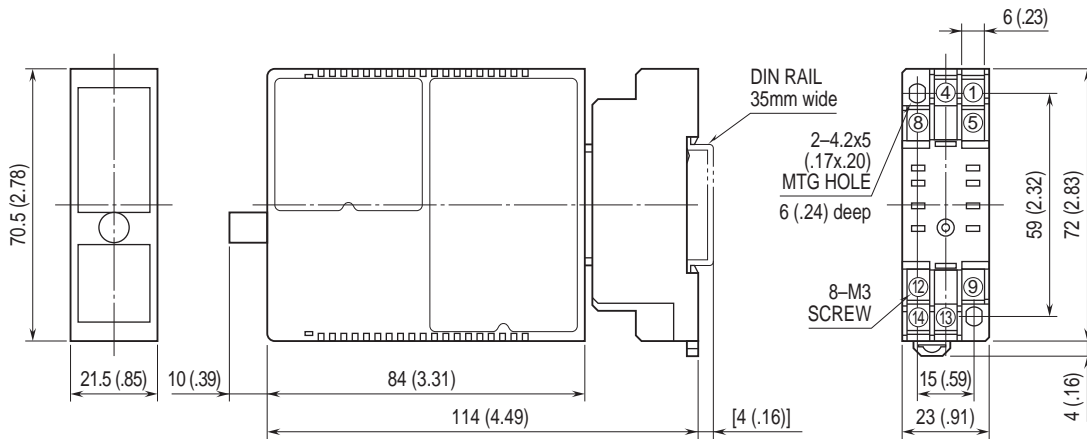

• When mounting, no extra space is needed between units.

TERMINAL ASSIGNMENTS unit: mm (inch)

INPUT RESISTOR
(model: REM2)

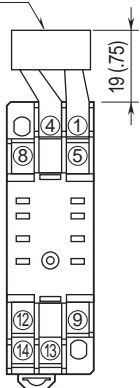

Input shunt resistor attached
for current input.

SCHEMATIC CIRCUITRY & CONNECTION DIAGRAM

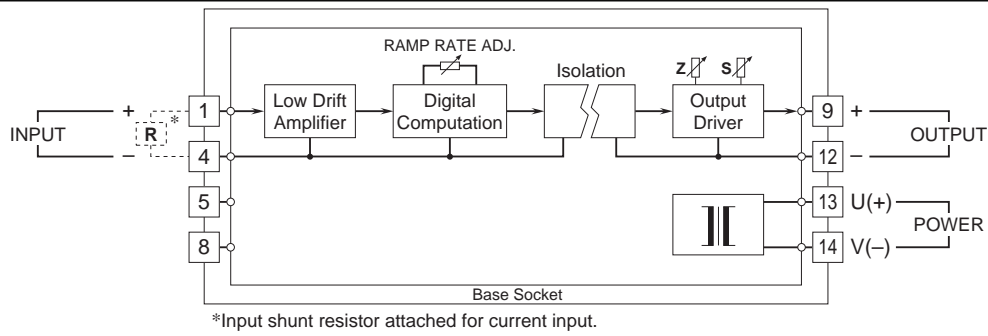

Specifications are subject to change without notice.