

UNIVERSAL TRANSMITTER
(PC programmable; Modbus-RTU communication)MODEL **M2XUM****BEFORE USE**

Thank you for choosing M-System. Before use, please check contents of the package you received as outlined below.

If you have any problems or questions with the product, please contact M-System's Sales Office or representatives.

■ PACKAGE INCLUDES:

Signal conditioner
(body + base socket + input resistor + CJC sensor).... (1)

■ MODEL NO.

Confirm Model No. marking on the product to be exactly what you ordered.

■ INSTRUCTION MANUAL

This manual describes necessary points of caution when you use this product, including installation, connection and basic maintenance procedures.

To change I/O ranges, the JX Configurator Connection Kit (model: JXCON) is required. For detailed information, refer to the data sheet and instruction manual for the JXCON.

Functions supported by Modbus are explained in Modbus Protocol Reference Guide (EM-5650).

POINTS OF CAUTION**■ CONFORMITY WITH EC DIRECTIVES**

- This equipment is suitable for use in a Pollution Degree 2 environment and in Installation Category II, with the maximum operating voltage of 300V.

Basic insulation is maintained between signal input and output. Prior to installation, check that the insulation class of this unit satisfies the system requirements.

- Altitude up to 2000 meters
- The equipment must be mounted inside a panel.
- Risk of Electrical Shock: The front cover of the panel is to be opened only by qualified service personnel.
- The equipment must be installed such that appropriate clearance and creepage distances are maintained to conform to CE requirements. Failure to observe these requirements may invalidate the CE conformance.
- The actual installation environments such as panel configurations, connected devices, connected wires, may affect the protection level of this unit when it is integrated in a panel system. The user may have to review the CE requirements in regard to the whole system and employ additional protective measures to ensure the CE conformity.

■ POWER INPUT RATING & OPERATIONAL RANGE

- Locate the power input rating marked on the product and confirm its operational range as indicated below:
100 – 240V AC rating: 85 – 264V, 47 – 66 Hz, approx. 6VA
24V DC rating: 24V ±10%, approx. 3W
110V DC rating: 85 – 150V, approx. 3W

■ WARNING!

- To protect very delicate components contained inside the unit against damage from static electricity, wear a grounded wrist strap when handling them. If you do not have one, touch both of your hands to a safely grounded object or to a metal object.
- Ensure that the power supply and input signal are switched off before you plug in or remove the unit.

■ ENVIRONMENT

- Indoor use
- When heavy dust or metal particles are present in the air, install the unit inside proper housing with sufficient ventilation.
- Do not install the unit where it is subjected to continuous vibration. Do not subject the unit to physical impact.
- Environmental temperature must be within -30 to +60°C (-22 to +140°F) with relative humidity within 30 to 90% RH in order to ensure adequate life span and operation.
- Be sure that the ventilation slits are not covered with cables, etc.

■ WIRING

- Do not install cables (power supply, input and output) close to noise sources (relay drive cable, high frequency line, etc.).
- Do not bind these cables together with those in which noises are present. Do not install them in the same duct.

■ AND

- The unit is designed to function as soon as power is supplied, however, a warm up for 20 minutes is required for satisfying complete performance described in the data sheet.
- With voltage output, do not leave the output terminals shortcircuited for a long time. The unit is designed to endure it without breakdown, however, it may shorten appropriate life duration.

COMPONENT IDENTIFICATION

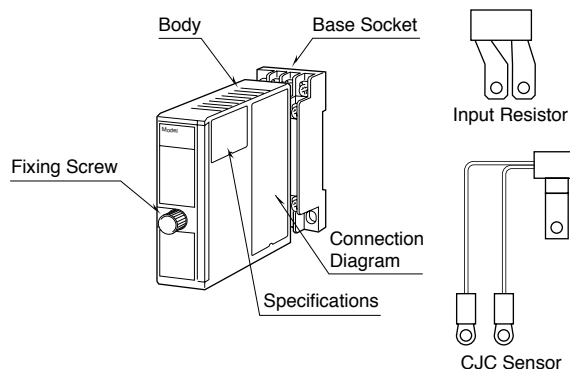

INSTALLATION

Loosen the fixing screw at the front of the unit in order to separate the body from the base socket.

■ DIN RAIL MOUNTING

Set the base socket so that its DIN rail adaptor is at the bottom. Position the upper hook at the rear side of base socket on the DIN rail and push in the lower. When removing the socket, push down the DIN rail adaptor utilizing a minus screwdriver and pull.

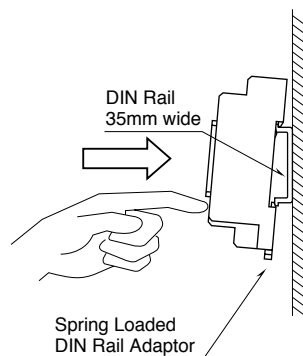

■ WALL MOUNTING

Refer to the drawings below.

TERMINAL CONNECTIONS

Connect the unit as in the diagram below or refer to the connection diagram on the side of the unit.

For a DC current input, attach the input resistor (model: REM2) together with input wiring to the input screw terminals.

For a thermocouple input, attach the CJC sensor (model: CJM) together with input wiring to the input terminals. The CJC sensor is not interchangeable. Check that its serial number is the same as that of the unit.

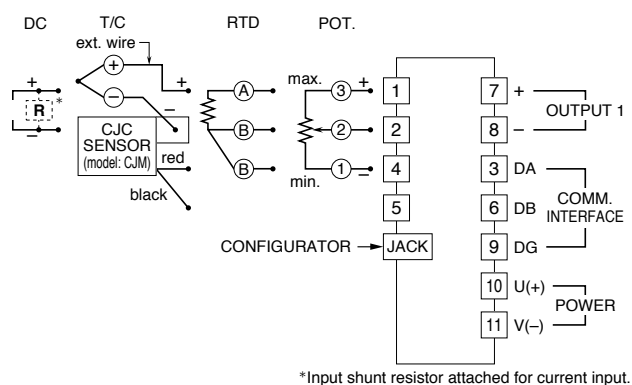

CHECKING

- 1) Terminal wiring: Check that all cables are correctly connected according to the connection diagram.
- 2) Input range selector: Check that the switch is at the appropriate position according to the input range model suffix code.
- 3) Power input voltage: Check voltage across the terminal 10 – 11 with a multimeter.
- 4) Input: Check that the input wires are correctly connected to the input terminals according to the selected input type.
- 5) Output: Check that the load resistance meets the described specifications.
- 6) Status indicator LED: Check that it flashes in a regular pattern.

HARDWARE ADJUSTMENTS

This unit is calibrated at the factory to meet the ordered specifications, therefore you usually do not need any calibration.

For matching the signal to a receiving instrument or in case of regular calibration, fine zero and span adjustments can be done to $\pm 5\%$ by pressing UP/DOWN switches enabled with the zero/span selector switch. Calibrated values are stored in the non-volatile memory, which will not be lost even when you turn off power supply to the unit. Zero and span are respectively set to 0% and 100% at the factory.

■ FRONT VIEW (with cover open)

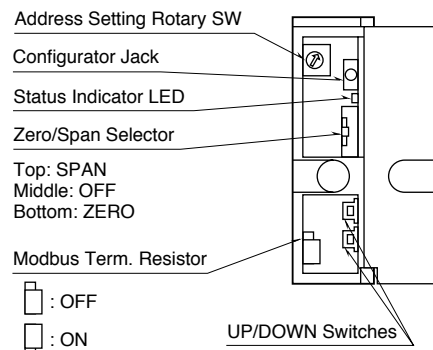

The front cover cannot be opened to 180 deg. when flush with neighboring units.

Zero/Span Selector

- ZERO:** UP/DOWN switches usable for zero adjustment.
- OFF:** UP/DOWN switches unavailable.
- SPAN:** UP/DOWN switches usable for span adjustment.

UP/DOWN Switches

(Incrementing speed will be doubled when the switch is held down.)

- UP:** Pressing UP increases adjusted values.
- DOWN:** Pressing DOWN decreases adjusted values.

■ HOW TO RESET

You can reset manually calibrated zero and span to their ex-factory state by pressing both UP/DOWN switches at once.

■ HOW TO CALIBRATE ZERO/SPAN

Use a signal source and measuring instruments of sufficient accuracy level. Turn the power supply on and warm up for more than 20 minutes.

- 1) ZERO: Apply 0% input. Slide the Zero/Span Selector to the bottom position. Press the UP or DOWN switches and adjust output to 0%.
- 2) SPAN: Apply 100% input. Slide the Zero/Span Selector to the top position. Press the UP or DOWN switches and adjust output to 100%.
- 3) Check ZERO adjustment again with 0% input.
- 4) The ZERO and SPAN adjustments are processed in a digital processor, and therefore do not interact. However, if ZERO value is changed, repeat the above procedure 1) - 3).

■ HOW TO CANCEL RESISTANCE IMBALANCES BETWEEN RTD LEADWIRES

Resistance imbalances between RTD leadwires can be cancelled by manipulating the Zero/Span Selector and UP/DOWN switches.

- 1) Press and hold down the DOWN switch. Switch the Zero/Span Selector to the bottom position and release the DOWN switch. Check that the status indicator LED which was flashing has turned ON.
- 2) Press the DOWN switch once and release to cancel any resistance imbalances.
- 3) Return the Zero/Span Selector to the middle position. The status indicator LED will start flashing again.

■ HOW TO CAPTURE THE POTENTIOMETER'S ZERO/SPAN

Particular positions of the potentiometer can be captured (stored in memory) as ZERO (0%) or SPAN (100%) points by manipulating Zero/Span Selector and UP/DOWN switches.

ZERO

- 1) Press and hold down the DOWN switch. Switch the Zero/Span Selector to the bottom position and release the DOWN switch. Check that the status indicator LED which was flashing has turned ON.
- 2) Press the DOWN switch once and release to capture zero.
- 3) Return the Zero/Span Selector to the middle position. The status indicator LED will start flashing again.

SPAN

- 1) Press and hold down the DOWN switch. Switch the Zero/ Span Selector to the top position and release the DOWN switch. Check that the status indicator LED which was flashing has turned ON.
- 2) Press the DOWN switch once and release to capture span.
- 3) Return the Zero/Span Selector to the middle position. The status indicator LED will start flashing again.

I/O RANGE SELECTOR

PC Configurator Software is used to change input and output specifications.

For the input codes S2 and Z1, the input range selector switch must be positioned to the H side. Check the switch position before you attempt to change the input type and calibration range.

■ INPUT RANGE SELECTOR

INPUT TYPE	SWITCH POSITION
S2 : -10 to +10V DC	H
Z1 : 0 to 50mA DC	H
All others	L

■ RIGHT SIDE VIEW

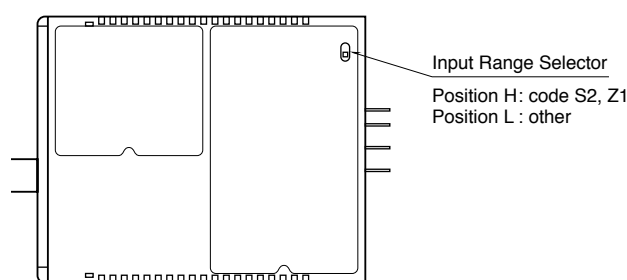

STATUS INDICATOR LED

The M2XUM is provided with a status indicator LED which flashes in different patterns indicating various status of its CPU.

When it is functioning within normal parameters, the LED flashes in a regular pattern of ON and OFF.

When the unit is in an abnormality, it flashes in particular patterns repeating approximately in 1.3 seconds.

The following figure indicates typical patterns. A white circle means that the light is OFF for 80 millise., while a black one means ON for 80 millise.

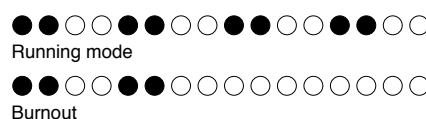

MAINTENANCE

Regular calibration procedure is explained below:

■ CALIBRATION

Warm up the unit for at least 20 minutes. Apply 0%, 25%, 50%, 75% and 100% input signal. Check that the output signal for the respective input signal remains within accuracy described in the data sheet. When the output is out of tolerance, recalibrate the unit according to the "HARDWARE ADJUSTMENT" explained earlier.

EXTERNAL DIMENSIONS unit: mm (inch)

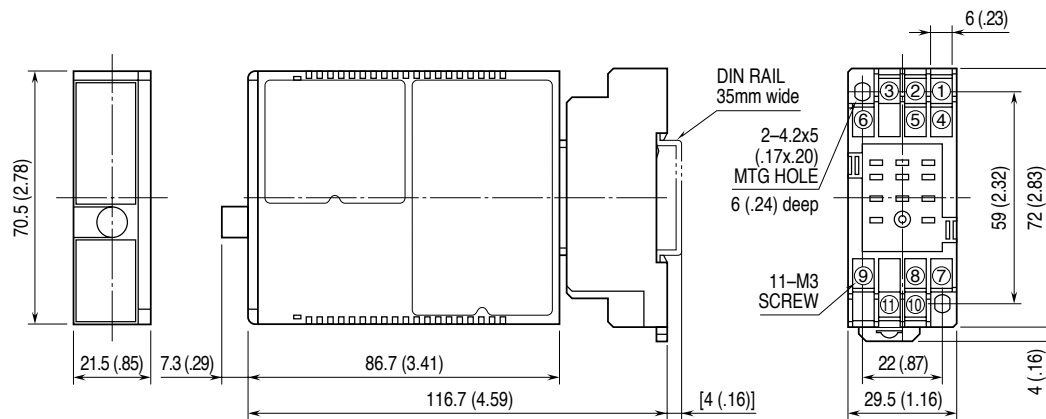

• When mounting, no extra space is needed between units.

■ TERMINAL ASSIGNMENTS

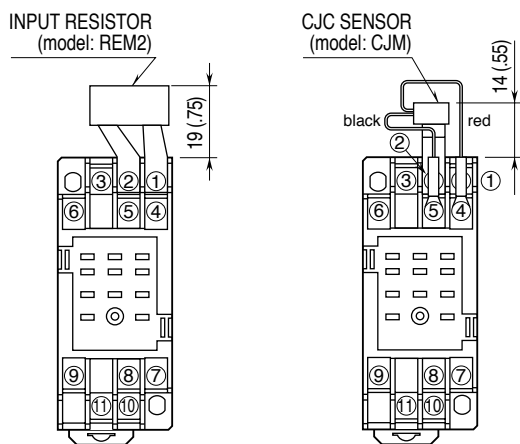

Use the input resistor (model: REM2) for a DC current input, and the CJC sensor (model: CJM) for a thermocouple input, both included in the package.

MODBUS FUNCTION CODES & SUPPORTED CODES

COMMUNICATION PARAMETERS

PARAMETERS	SPECIFICATIONS	DEFAULT	MODIFICATION
Data Mode	RTU	RTU	Not modifiable
Baud Rate	9600 / 19200 / 38400 bps	38400 bps	JXCON Software
Parity	None / Odd / Even	Odd	JXCON Software
Bit Length	8	8	Not modifiable
Stop Bit	1	1	Not modifiable
Node Addresses	1 to 247	1	Hardware Rotary SW for 1 through 16, JXCON Software for 16 through 247 (Rotary SW set to 0).
Floating Point Data	Normal / Swapped	Normal	JXCON Software
Physical Layer	RS-485	RS-485	Not modifiable

FUNCTION CODES

CODE	NAME *1	NOTES
01 (0X01)	Read Coil Status	Reading DO
02 (0X02)	Read Input Status	Reading DI
03 (0X03)	Read Holding Register	
04 (0X04)	Read Input Register	
05 (0X05)	Force Single Coil	Writing single DO
06 (0X06)	Preset Single Register	
15 (0X0F)	Force Multiple Coils	Writing multiple DO
16 (0X10)	Force Multiple Registers	

*1. Based upon Modbus Protocol Reference Guide PI-MBUS-300

DATA ADDRESS

	ADDRESS	DATA FORMAT	NAME
Coil (0X)	1 – 16		DO (internal switch)
	17		Operation Mode SW (0 : Programming Mode, 1 : Run Mode)
	18		Cold junction compensation SW (0 : Disable, 1 : Enable) *2
	19		Linearization SW (0 : Disable, 1 : Enable) *3
	23		Remote output mode SW (0 : Local, 1 : Remote)
Input Status (1X)	1 – 16		DI (internal switch)
	17		Input data error (0 : Normal, 1 : Error)
Input Register (3X)	1 – 2	F	AI in %
	3 – 4	F	AI in engineering unit
	5 – 6	F	Cold junction temperature (°C, °F or K) *2
	7	I	AI in % *4
	8	I	Bit
			Status Description
			0 – 3 Reserved for system's use 4 1 : ADC Channel 1 Overrange 5 1 : ADC Channel 2 Overrange 6 1 : Burnout Detected 7 1 : ADC Hardware Error Detected 8 – 15 Reserved for system's use
	129 – 144	B16	Model No. "M2XUM"
Holding Register (4X)	1 – 2	F	AO in % *5
	3	I	AO in % *4,*5
	4	I	Input type No. *6
	5	I	Temperature unit (3 : °C, 4 : °F, 5 : K) *7
	6	I	Burnout type (0 : No Burnout, 1 : Downscale, 2 : Upscale)
	7	I	(Reserved)
	8	I	#1 output type No. (0 : 0 – 20mA, 1 : ±2.5V, 2 : ±10V) *6
	9 – 10	I	(Reserved, integer)
	17 – 18	F	Input 100% scaled value
	19 – 20	F	Input 0% scaled value
	21 – 22	F	Output 100% scaled value (V or A)
	23 – 24	F	Output 0% scaled value (V or A)
	25 – 28	F	(Reserved, 32-bit floating)
	29 – 33	B10	Tag No.

I = 16-bit integer, F = 32-bit floating, Bn = n-byte character

*2. Thermocouple input *3. DC and Potentiometer input *4. 0 – 100% converted into 0 – 20000

*5. Remote Output Mode SW automatically turned ON when reading

*6. Be sure to scale 0% and 100% after the input type has been changed. *7. Thermocouple and RTD input

■ INPUT TYPE & RANGE

I/O	I/O TYPE	SELECTION	USABLE RANGE
DC input	0	0 – 50 mA	0 – 50 mA
	1	-1 – 1 V	-1 – 1 V
	2	-10 – 10 V	-10 – 10 V
T/C input	16	(PR)	0 – 1760 °C
	17	K (CA)	-270 – 1370 °C
	18	E (CRC)	-270 – 1000 °C
	19	J (IC)	-210 – 1200 °C
	20	T (CC)	-270 – 400 °C
	21	B (RH)	0 – 1820 °C
	22	R	-50 – 1760 °C
	23	S	-50 – 1760 °C
	24	C (WRe 5-26)	0 – 2315 °C
	25	N	-270 – 1300 °C
	26	U	-200 – 400 °C
	27	L	-200 – 900 °C
RTD input	28	P (Platinel II)	0 – 1395 °C
	29	User's T/C	
	32	JPt 100 (JIS '89)	-200 – 500 °C
	33	Pt 100 (JIS '89)	-200 – 850 °C
	34	Pt 100 (JIS '97, IEC)	-200 – 850 °C
	35	Pt 50 (JIS '81)	-200 – 649 °C
	36	Ni 508.4	-50 – 200 °C
	37	Pt 1000	-200 – 200 °C
POT input	38	Ni 100	-50 – 200 °C
	39	Cu 10 @25°C	-50 – 200 °C
	40	User's RTD	
	48	0 – 100 ohms	0 – 100 %
	49	0 – 300 ohms	0 – 100 %
	50	0 – 1k ohms	0 – 100 %
	51	0 – 10k ohms	0 – 100 %

Caution: Be sure to scale 0% and 100% input after the input type No. has been changed.

M-SYSTEM WARRANTY

M-System warrants such new M-System product which it manufactures to be free from defects in materials and workmanship during the 36-month period following the date that such product was originally purchased if such product has been used under normal operating conditions and properly maintained, M-System's sole liability, and purchaser's exclusive remedies, under this warranty are, at M-System's option, the repair, replacement or refund of the purchase price of any M-System product which is defective under the terms of this warranty. To submit a claim under this warranty, the purchaser must return, at its expense, the defective M-System product to the below address together with a copy of its original sales invoice.

THIS IS THE ONLY WARRANTY APPLICABLE TO M-SYSTEM PRODUCT AND IS IN LIEU OF ALL OTHER WARRANTIES, EXPRESS OR IMPLIED, INCLUDING ANY IMPLIED WARRANTIES OF MERCHANTABILITY OR FITNESS FOR A PARTICULAR PURPOSE. M-SYSTEM SHALL HAVE NO LIABILITY FOR CONSEQUENTIAL, INCIDENTAL OR SPECIAL DAMAGES OF ANY KIND WHATSOEVER.

M-System Co., Ltd., 5-2-55, Minamitsumori, Nishinari-ku, Osaka 557-0063 JAPAN, Phone: (06) 6659-8201, Fax: (06) 6659-8510, E-mail: info@m-system.co.jp