

INSTALLATION BASE
(8 positions; connector output)

MODEL **M2BS-8U1**

BEFORE USE

Thank you for choosing M-System. Before use, check the package you received as below.

If you have any problems or questions with the product, please contact M-System's Sales Office or representatives.

■ **PACKAGE INCLUDES:**

Installation base (1)

■ **MODEL NO.**

Check that model No. described on specification label is exactly what you ordered.

■ **INSTRUCTION MANUAL**

This manual describes necessary points of caution when you use this product, installation, connection and basic maintenance procedures.

MOUNTING REQUIREMENTS mm (inch)

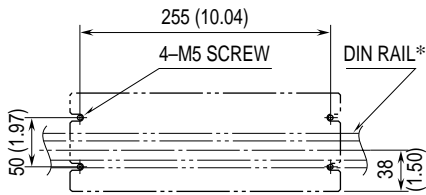

*Installed in horizontal direction only.

■ **HOW TO MOUNT THE M2BS ON A DIN RAIL**

Push in the sections A on the base.

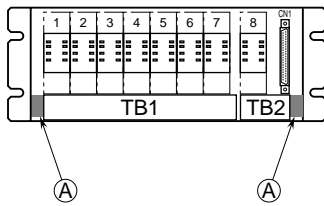

■ **HOW TO REMOVE THE M2BS**

- 1) Open the terminal covers for TB1 and TB2.
- 2) Hold the base as in the figure below. Push down the DIN rail adapters B and then C utilizing a screwdriver (-), and pull.

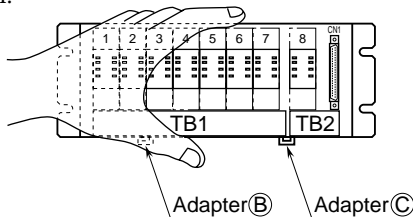

CHECKING

- 1) Terminal wiring: Check that all cables are correctly connected according to the connection diagrams of the installation base and the mounted signal conditioners.
- 2) Power input voltage
- 3) Installation & environment

POINTS OF CAUTION

■ **CONFORMITY WITH CE/LVD DIRECTIVE**

- This equipment is suitable for use in a Pollution Degree 2 environment and in Installation Category III, with the maximum operating voltage 300V. Basic insulation is maintained between the input and output. Prior to installation, check that the insulation class of this unit satisfies the system requirements.
- Altitude up to 2000 meters
- The equipment must be mounted inside a panel.
- The equipment must be installed such that appropriate clearance and creepage distances are maintained to conform to CE requirements. Failure to observe these requirements may invalidate the CE conformity.

■ **POWER INPUT RATINGS**

- Power input ratings are specified by the model number suffix code. Check the power input voltage for the unit on the specification label.

AC power: 85 – 264V, 47 – 66 Hz

DC power: 24V ±10%

■ **UNPLUGGING THE UNIT**

- Before you remove the unit from the base or mount it, turn off the power supply and input signal for safety.

■ **ENVIRONMENT**

- Indoor use
- When heavy dust or metal particles are present in the air, install the unit inside proper housing and ventilate it.
- Do not install the unit where it is subjected to continuous vibration. Do not apply physical impact to the unit.
- Environmental temperature must be within -5 to +55°C (23 to 131°F) with relative humidity within 30 to 90% RH in order to ensure adequate life span and operation.
- Be sure that the ventilation slits are not covered with cables, etc.

■ **WIRING**

- Do not install cables (power supply, input and output) close to noise sources (relay drive cable, high frequency line, etc.).
- Do not bind these cables together with those in which noises are present. Do not install them in the same duct.

TERMINAL CONNECTIONS

Connect the unit as in the diagram below referring the other drawings.

EXTERNAL DIMENSIONS mm (inch)

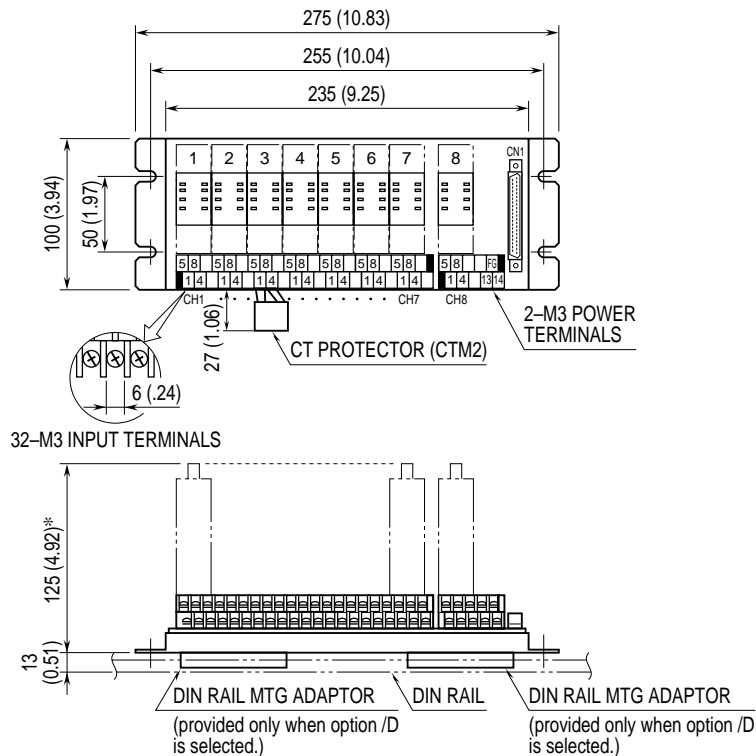

*165 (6.50) required for pneumatic tubing for M2PV.

CONNECTION DIAGRAM

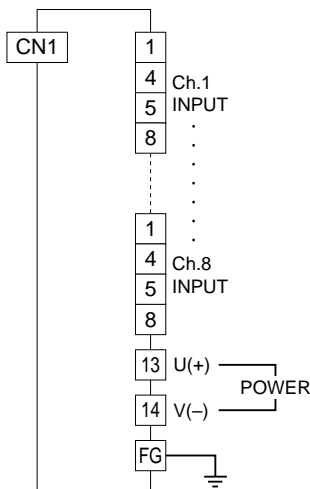

CONNECTOR PIN ASSIGNMENT

I/O Connector: Fujitsu FCN364P040-AU

CN1: output

PIN NO.	ASSIGNMENT	PIN NO.	ASSIGNMENT
A 1	ch. 1 +	B 1	ch. 1 -
A 2	ch. 2 +	B 2	ch. 2 -
A 3	ch. 3 +	B 3	ch. 3 -
A 4	ch. 4 +	B 4	ch. 4 -
A 5	ch. 5 +	B 5	ch. 5 -
A 6	ch. 6 +	B 6	ch. 6 -
A 7	ch. 7 +	B 7	ch. 7 -
A 8	ch. 8 +	B 8	ch. 8 -

A8 - A20, B8 - B20: Unused

M-SYSTEM WARRANTY

M-System warrants such new M-System product which it manufactures to be free from defects in materials and workmanship during the 36-month period following the date that such product was originally purchased if such product has been used under normal operating conditions and properly maintained, M-System's sole liability, and purchaser's exclusive remedies, under this warranty are, at M-System's option, the repair, replacement or refund of the purchase price of any M-System product which is defective under the terms of this warranty. To submit a claim under this warranty, the purchaser must return, at its expense, the defective M-System product to the below address together with a copy of its original sales invoice. THIS IS THE ONLY WARRANTY APPLICABLE TO M-SYSTEM PRODUCT AND IS IN LIEU OF ALL OTHER WARRANTIES, EXPRESS OR IMPLIED, INCLUDING ANY IMPLIED WARRANTIES OF MERCHANTABILITY OR FITNESS FOR A PARTICULAR PURPOSE. M-SYSTEM SHALL HAVE NO LIABILITY FOR CONSEQUENTIAL, INCIDENTAL OR SPECIAL DAMAGES OF ANY KIND WHATSOEVER.

M-System Co., Ltd., 5-2-55, Minamitsumori, Nishinari-ku, Osaka 557-0063 JAPAN, Phone: (06) 6659-8201, Fax: (06) 6659-8510, E-mail: info@m-system.co.jp