

<p>DC ALARM (thumbwheel switch adjustment; DPDT output)</p>	<p>MODEL M2AS</p>
--	--------------------------

BEFORE USE

Thank you for choosing M-System. Before use, please check contents of the package you received as outlined below. If you have any problems or questions with the product, please contact M-System's Sales Office or representatives.

PACKAGE INCLUDES:

- Signal conditioner (body + base socket + input resistor)..... (1)
- Input resistor is provided only with current input type.

MODEL NO.

Confirm Model No. marking on the product to be exactly what you ordered.

INSTRUCTION MANUAL

This manual describes necessary points of caution when you use this product, including installation, connection and basic maintenance procedures.

POINTS OF CAUTION

CONFORMITY WITH EC DIRECTIVES

- This equipment is suitable for use in a Pollution Degree 2 environment and in Installation Category II, with the maximum operating voltage of 300V. Basic insulation is maintained between signal input and output. Prior to installation, check that the insulation class of this unit satisfies the system requirements.
- Altitude up to 2000 meters
- The equipment must be mounted inside a panel.
- The equipment must be installed such that appropriate clearance and creepage distances are maintained to conform to CE requirements. Failure to observe these requirements may invalidate the CE conformance.

POWER INPUT RATING & OPERATIONAL RANGE

- Locate the power input rating marked on the product and confirm its operational range as indicated below:
 100 – 240V AC rating: 85 – 264V, 47 – 66 Hz, approx. 3 – 5VA
 24V DC rating: 24V ±10%, approx. 3W
 11 – 27V DC rating: 11 – 27V, approx. 3W
 110V DC rating: 85 – 150V, approx. 3W

GENERAL PRECAUTIONS

- Before you remove the unit from its base socket or mount it, turn off the power supply and input signal for safety.
- DO NOT apply excessive pressure on the thumbwheel switches.

ENVIRONMENT

- Indoor use
- When heavy dust or metal particles are present in the air, install the unit inside proper housing with sufficient ventilation.
- Do not install the unit where it is subjected to continuous vibration. Do not subject the unit to physical impact.
- Environmental temperature must be within -5 to +55°C (23 to 131°F) with relative humidity within 30 to 90% RH in order to ensure adequate life span and operation.
- Be sure that the ventilation slits are not covered with cables, etc.

WIRING

- Do not install cables (power supply, input and output) close to noise sources (relay drive cable, high frequency line, etc.).
- Do not bind these cables together with those in which noises are present. Do not install them in the same duct.

AND

- The unit is designed to function as soon as power is supplied, however, a warm up for 10 minutes is required for satisfying complete performance described in the data sheet.

COMPONENT IDENTIFICATION

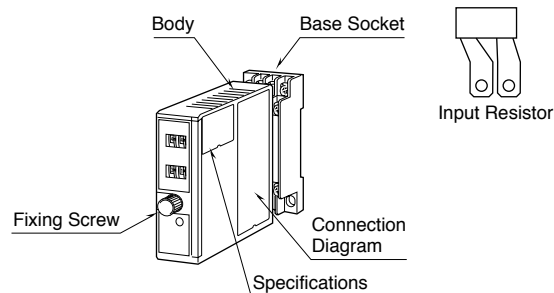

FRONT PANEL CONFIGURATION

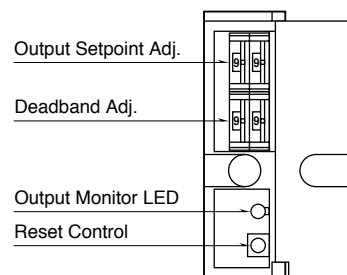

INSTALLATION

Loosen the fixing screw at the front of the unit in order to separate the body from the base socket.

■ DIN RAIL MOUNTING

Set the base socket so that its DIN rail adaptor is at the bottom. Position the upper hook at the rear side of base socket on the DIN rail and push in the lower. When removing the socket, push down the DIN rail adaptor utilizing a minus screwdriver and pull.

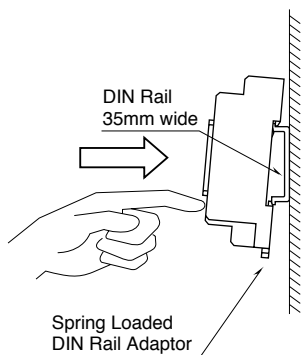

■ WALL MOUNTING

Refer to "EXTERNAL DIMENSIONS."

TERMINAL CONNECTIONS

Connect the unit as in the diagram below or refer to the connection diagram on the side of the unit.

When an input resistor is provided with the module, attach it together with input wiring to the input screw terminals.

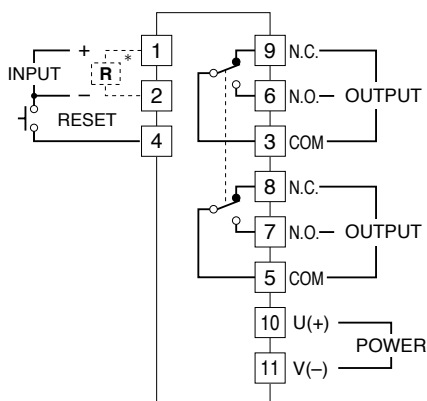

*Input shunt resistor attached for current input.

CHECKING

- 1) Terminal wiring: Check that all cables are correctly connected according to the connection diagram.
- 2) Power input voltage: Check voltage across the terminal 10 – 11 with a multimeter.
- 3) Input: Check that the input signal is within 0 – 100% of the full-scale.
- 4) Alarm operations: Check the alarm operations referring to the figure below.
- 5) Output load: Check that the output load is 250V AC/600VA (300VA with enclosed relay) or 30V DC/150W at the maximum. For maximum relay life with inductive loads, external protection is recommended.

Alarm Trip Operation

Terminal No. in parentheses

• Output Code : 1, 4

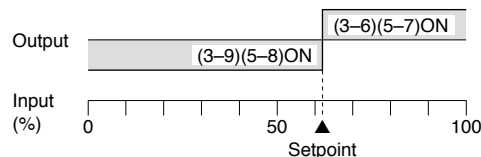

• Output Code : 2, 3

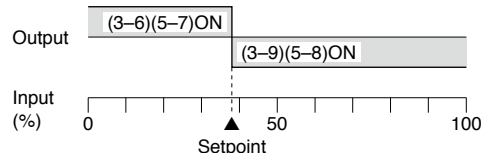

Trip Operation in Power Failure: Terminals 3 – 9 and 5 – 8 turn on.

SETPOINT ADJUSTMENTS

Turn the thumbwheel switches until desired figures in percent are shown. The output operation is set to "Latching" when the Deadband Adj. is set to 00. Monitor LED turns on when the coil is energized ([input] > [setpoint] for Codes 1 or 4, [input] < [setpoint] for Codes 2 or 3). The two transfer contacts trip at the same time when the signal input goes across the threshold.

MAINTENANCE

Regular calibration procedure is explained below:

■ CALIBRATION

Warm up the unit for at least 10 minutes.

• Hi Alarm

Increase the input signal from a value lower than the setpoint and check that the relay trips at the setpoint.

• Lo Alarm

Decrease the input signal from a value higher than the setpoint and check that the relay trips at the setpoint.

When the setpoints are shifted, contact M-System's Sales Office or representatives.

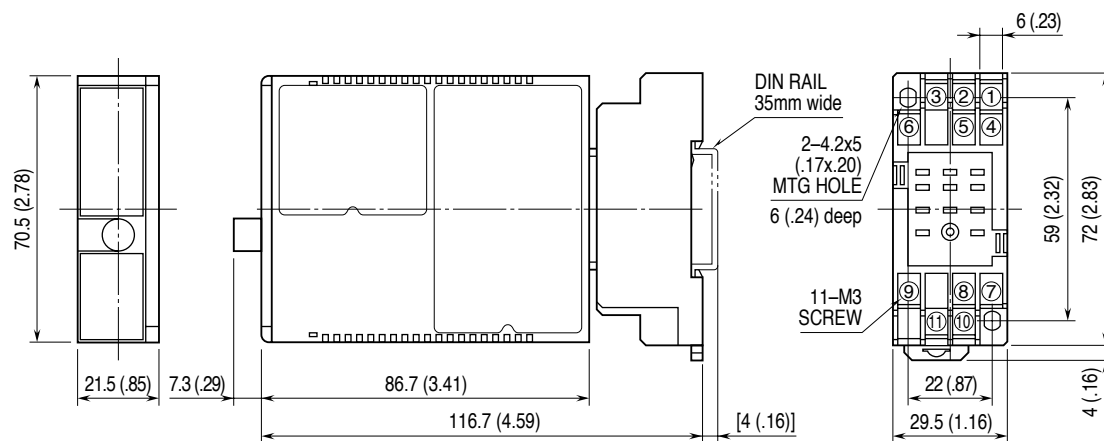
EXTERNAL DIMENSIONS unit: mm (inch)

• When mounting, no extra space is needed between units.

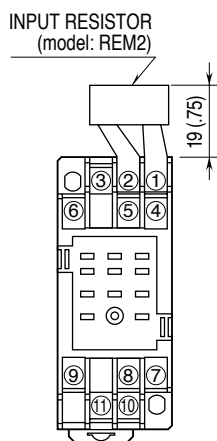
■ TERMINAL ASSIGNMENTS

Input shunt resistor attached
for current input.

M-SYSTEM WARRANTY

M-System warrants such new M-System product which it manufactures to be free from defects in materials and workmanship during the 36-month period following the date that such product was originally purchased if such product has been used under normal operating conditions and properly maintained, M-System's sole liability, and purchaser's exclusive remedies, under this warranty are, at M-System's option, the repair, replacement or refund of the purchase price of any M-System product which is defective under the terms of this warranty. To submit a claim under this warranty, the purchaser must return, at its expense, the defective M-System product to the below address together with a copy of its original sales invoice.

THIS IS THE ONLY WARRANTY APPLICABLE TO M-SYSTEM PRODUCT AND IS IN LIEU OF ALL OTHER WARRANTIES, EXPRESS OR IMPLIED, INCLUDING ANY IMPLIED WARRANTIES OF MERCHANTABILITY OR FITNESS FOR A PARTICULAR PURPOSE. M-SYSTEM SHALL HAVE NO LIABILITY FOR CONSEQUENTIAL, INCIDENTAL OR SPECIAL DAMAGES OF ANY KIND WHATSOEVER.

M-System Co., Ltd., 5-2-55, Minamitsumori, Nishinari-ku, Osaka 557-0063 JAPAN, Phone: (06) 6659-8201, Fax: (06) 6659-8510, E-mail: info@m-system.co.jp