

DDR3 VLP-Unbuffered DIMM Module

4GB based on 2Gbit component

TFBGA with Pb-Free



Revision 1.0 (MAY. 2007)
-Initial Release

1.0 Feature

- JEDEC standard 1.5V ± 0.075V Power Supply
- VDDQ = 1.5V ± 0.075V
- Programmable CAS latencies 6,7,8,9,10,11,13
- Programmable Additive Latency(Posted CAS) : 0, CL - 2, or CL - 1 clock
- Programmable CAS Write Latency(CWL) = 5 (DDR3-800), 6 (DDR3-1066), 7 (DDR3-1333), 8 (DDR3-1600) and 9 (DDR3-1866)
- 400MHz fCK for 800Mb/sec/pin, 533MHz fCK for 1066Mb/sec/pin, 667MHz fCK for 1333Mb/sec/pin, 800MHz fCK for 1600Mb/sec/pin, 900MHz fCK for 1866Mb/sec/pin
- Bi-directional Differential Data Strobe
- Burst Length: 8 (Interleave without any limit, sequential with starting address “000” only), 4 with tCCD = 4 which does not allow seamless read or write [either On the fly using A12 or MRS]
- On-Die termination using ODT pin
- 8 independent internal bank
- Asynchronous Reset
- Average Refresh Period 7.8us at lower than a TCASE 85°C, 3.9us at 85°C < TCASE < 95 °C
- Serial presence detect with EEPROM
- VLP-UDIMM Dimension (Nominal) 18.75 mm high, 133.35 mm wide
- Based on JEDEC standard reference Raw Cards Lay out.
- RoHS compliant
- Gold plated contacts

2.0 Ordering Information

Part number	Density	Module Organization	Component composition	Component PKG	Module Rank	Description
W1600LB4GS	4GB	512Mx64	256Mx8*16	TFBGA	2	4GB 2Rx8 PC3-12800U

Note: Last Character of the Part Number stand for DRAM vendor
S=Samsung; M=Micron; H=Hynix

3.0 Key Timing Parameters

	DDR3-1600	Unit
CL-tRCD-tRP	11-11-11	tCK
CAS Latency	11	tCK
tCK(min)	1.25	ns
tRCD(min)	13.5	ns
tRP(min)	13.5	ns
tRAS(min)	35	ns
tRC(min)	48.75	ns

4.0 Absolute Maximum DC Rating

Symbol	Parameter	Rating	Units
V _{in} , V _{out}	Voltage on any pin relative to V _{SS}	-0.4 ~ 1.975	V
V _{DD}	Voltage on V _{DD} & V _{DDQ} supply relative to V _{SS}	-0.4 ~ 1.975	V
V _{DDQ}	Short circuit current	-0.4 ~ 1.975	V
V _{DDL}	Power dissipation	-0.4 ~ 1.975	V
T _{STG}	Storage Temperature	-55 ~ + 100	°C

5.0 DIMM Pin Configurations (Front side/Back side)

Pin	Front	Pin	Back	Pin	Front	Pin	Back	Pin	Front	Pin	Back
1	V _{REF} DQ	121	Vss	41	Vss	161	DM8/DQS17_P	81	DQ32	201	DQ37
2	Vss	122	DQ4	42	NC	162	DQS17_N	82	DQ33	202	Vss
3	DQ0	123	DQ5	43	NC	163	Vss	83	Vss	203	DM4/DQS13_P
4	DQ1	124	Vss	44	Vss	164	NC	84	DQS4_N	204	DQS13_N
5	Vss	125	DM0/DQS9_P	45	NC	165	NC	85	DQS4_P	205	Vss
6	DQS0_N	126	NC/DQS9_N	46	NC	166	Vss	86	Vss	206	DQ38
7	DQS0_P	127	Vss	47	Vss	167	NC/TEST	87	DQ34	207	DQ39
8	Vss	128	DQ6	48	NC	168	RESET_N	88	DQ35	208	Vss
9	DQ2	129	DQ7	KEY				89	Vss	209	DQ44
10	DQ3	130	Vss	49	NC	169	CKE1	90	DQ40	210	DQ45
11	Vss	131	DQ12	50	CKE0	170	VDD	91	DQ41	211	Vss
12	DQ8	132	DQ13	51	VDD	171	A15	92	Vss	212	DM5/DQS14_P
13	DQ9	133	Vss	52	BA2	172	A14	93	DQS5_N	213	DQS14_N
14	Vss	134	DM1/DQS10_P	53	NC/Err-Out	173	VDD	94	DQS5_P	214	Vss
15	DQS1_N	135	DQS10_N	54	VDD	174	A12	95	Vss	215	DQ46
16	DQS2_P	136	Vss	55	A11	175	A9	96	DQ42	216	DQ47
17	Vss	137	DQ14	56	A7	176	VDD	97	DQ43	217	Vss
18	DQ10	138	DQ15	57	VDD	177	A8	98	Vss	218	DQ52
19	DQ11	139	Vss	58	A5	178	A6	99	DQ48	219	DQ53
20	Vss	140	DQ20	59	A4	179	VDD	100	DQ49	220	Vss
21	DQ16	141	DQ21	60	VDD	180	A3	101	VSS	221	DM6_DQS15_P
22	DQ17	142	Vss	61	A2	181	A1	102	DQS6_N	222	DQS15_N
23	Vss	143	DQS11_P	62	VDD	182	VDD	103	DQS6_P	223	Vss
24	DQS2_N	144	DQS11_N	63	CK1_P/NC	183	VDD	104	Vss	224	DQ54
25	DQS2_P	145	Vss	64	CK1_N/NC	184	CK0_P	105	DQ50	225	DQ55
26	Vss	146	DQ22	65	VDD	185	CK0_N	106	DQ51	226	Vss
27	DQ18	147	DQ23	66	VDD	186	VDD	107	Vss	227	DQ60
28	DQ19	148	Vss	67	V _{REF} CA	187	NC/EVENT	108	DQ56	228	DQ61
29	Vss	149	DQ28	68	NC, Par_In	188	A0	109	DQ57	229	Vss
30	DQ24	150	DQ29	69	VDD	189	VDD	110	Vss	230	DM7/DQS16_P
31	DQ25	151	Vss	70	A10/AP	190	BA1	111	DQS7_N	231	DQS16_N
32	Vss	152	DM3/DQS12_P	71	BA0	191	VDD	112	DQS7_P	232	Vss
33	DQ3_N	153	DQS12_N	72	VDD	192	RAS_N	113	Vss	233	DQ62
34	DQ3_P	154	Vss	73	WE	193	S0_N	114	DQ58	234	DQ63
35	Vss	155	DQ30	74	CAS	194	VDD	115	DQ59	235	Vss
36	DQ26	156	DQ31	75	VDD	195	ODT0	116	Vss	236	V _{DD} SPD
37	DQ27	157	Vss	76	S1	196	A13	117	SA0	237	SA1
38	Vss	158	NC	77	ODT1	197	VDD	118	SCL	238	SDA
39	NC	159	NC	78	VDD	198	NC	119	SA2	239	Vss
40	NC	160	Vss	79	S2/NC	199	Vss	120	V _{TT}	240	V _{TT}
				80	Vss	200	DQ36				

NC = No Connect, RFU = Reserved for Future Use

1. Par_in and Err_out pins are intended for register control functions.

6.0 DIMM Pin Description

Pin Name	Function	Pin Name	Function
A0 ~ A15	Address input (Multiplexed)	ODT0~ODT1	On Die Termination
A10/AP	Address Input/Auto pre-charge	CB0~CB7	ECC Data check bits Input/Output
BA0 ~ BA2	Bank Select	DQ0~DQ63	Data Input/Output
$\overline{CK0} \sim \overline{CK2}$, CK0~CK2	Clock input	$\overline{DQS0} \sim \overline{DQS8}$	Data strobes, negative line
CKE0, CKE1	Clock enable input	DM (0~8),	Data Masks/Data strobes (Read)
$\overline{S0}$, $\overline{S1}$	Chip select input	DQS0~DQS8	Data Strobes
\overline{RAS}	Row address strobe	RFU	Reserved for future used
\overline{CAS}	Column address strobe	V _{TT}	SDRAM I/O termination power supply
\overline{WE}	Write Enable	TEST	Memory bus test tool
SCL	SPD Clock Input	V _{DD}	Core Power
SDA	SPD Data Input/Output	V _{DDQ}	I/O Power
SA0~SA2	SPD Address	V _{SS}	Ground
Par_In	Parity bit for address & Control bus	V _{REFDQ}	SDRAM Input/Output Reference Supply
Err_Out	Parity error found in the Address and Control bus	V _{DDSPD}	Serial EEPROM Power Supply
\overline{RESET}	Register and PLL control pin	V _{REFCA}	Command Address Reference Supply

7.0 Address Configuration

Organization	Row Address	Column Address	Bank Address	Auto Pre-charge
256Mx8(2Gb) base	A0-A14	A0-A9	BA0-BA2	A10/AP

240-Pin VLP-Unbuffered DIMM

DDR3 SDRAM

8.0 Functional Block Diagram: 4GB, 512Mx64 Module (Populated as 2 ranks of x8)

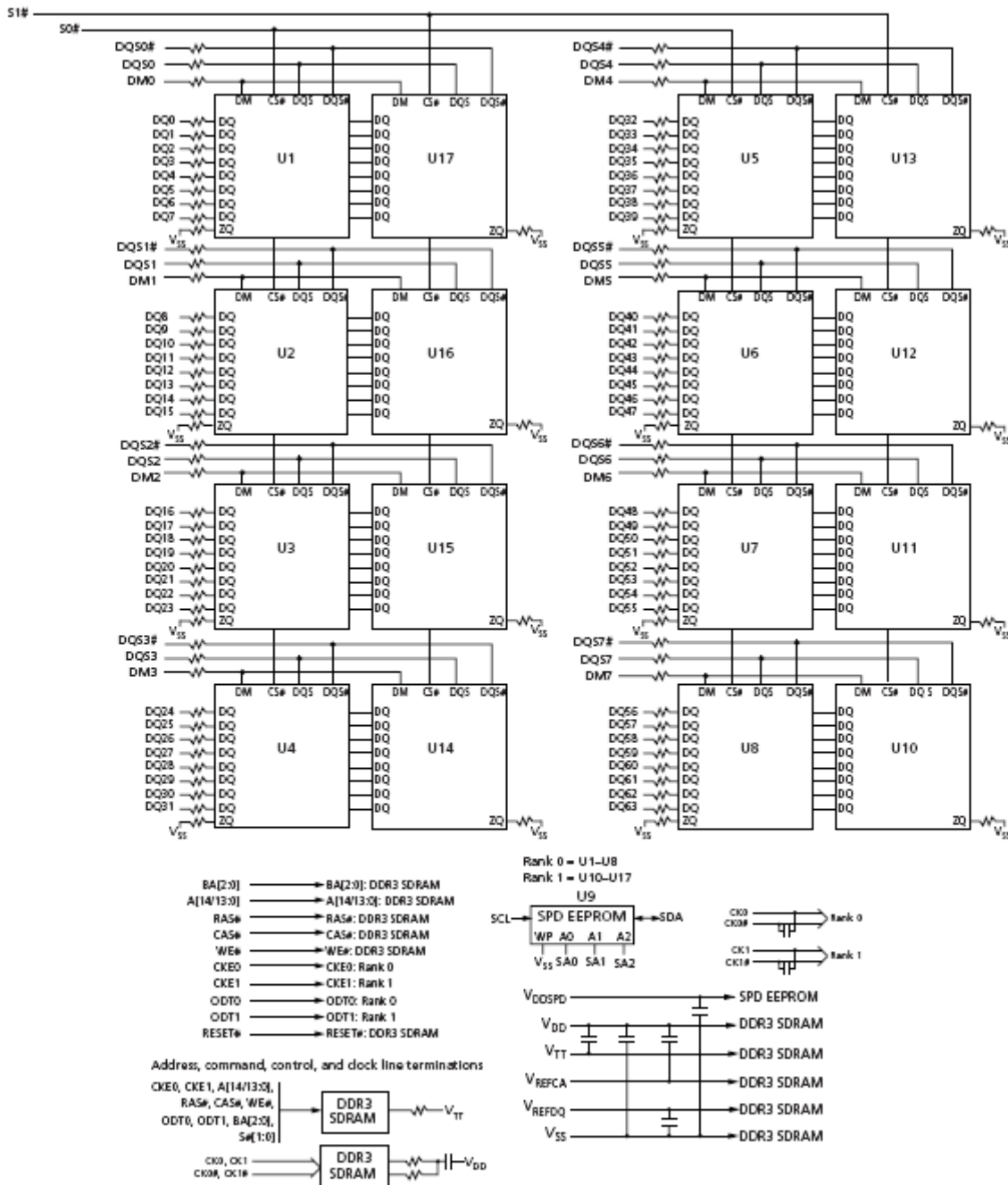

Note: 1. The ZQ ball on each DDR3 component is connected to an external 240Ω ±1% resistor that is tied to ground. Used for the calibration of the component's on-die termination and output driver.

9.0 AC & DC Operating Conditions

Recommended operating conditions (Voltage referenced to V_{SS}=0V, TA=0 to 70°C)

Symbol	Parameter	Min	Typ	Max	Unit
V _{DD}	Supply Voltage	1.425	1.5	1.575	V
V _{DDQ}	Supply Voltage for Output	1.425	1.5	1.575	V
V _{REFDQ(DC)}	I/O Reference Voltage (DQ)	0.49*V _{DDQ}	0.50*V _{DDQ}	0.51*V _{DDQ}	V
V _{REFCA(DC)}	I/O Reference Voltage (CMD/Add)	0.49*V _{DDQ}	0.50*V _{DDQ}	0.51*V _{DDQ}	V
V _{TT}	Termination Voltage	0.49*V _{DDQ}	0.50*V _{DDQ}	0.51*V _{DDQ}	V

10.0 Capacitance (Max.)

Symbol	Parameter/Condition	Min	Max	Unit
CCK	Input capacitance, CK and \overline{CK}	-	11	pF
CI1	Input capacitance, CKE and \overline{CS}	-	12	pF
CI2	Input capacitance, Addr, \overline{RAS} , \overline{CAS} , \overline{WE}	-	12	pF
CIO	Input capacitance, DQ, DM, DQS, \overline{DQS}	-	10	pF

11.1 AC Timing Parameters & Specifications

(AC operating conditions unless otherwise noted)

Parameter	Symbol	DDR3-1600		Units
		min	max	
Minimum Clock Cycle Time (DLL off mode)	tCK(DLL_OFF)	8	-	ns
Average Clock Period	tCK(avg)	-		ps
Clock Period	tCK(abs)	tCK(avg) min +tJIT(per)min	tCK(avg) max +tJIT(per)max	ps
Average high pulse width	tCH(avg)	0.47	0.53	tCK(avg)
Average low pulse width	tCL(avg)	0.47	0.53	tCK(avg)
Clock Period Jitter	tJIT(per)	-70	70	ps
Clock Period Jitter during DLL locking period	tJIT(per, lck)	-60	60	ps
Cycle to Cycle Period Jitter	tJIT(cc)	140	-	ps
Cycle to Cycle Period Jitter during DLL locking period	tJIT(cc, lck)	120	-	ps
Cumulative error across 2 cycles	tERR(2per)	- 103	103	ps
Cumulative error across 3 cycles	tERR(3per)	- 122	122	ps
Cumulative error across 4 cycles	tERR(4per)	- 136	136	ps
Cumulative error across 5 cycles	tERR(5per)	- 147	147	ps
Cumulative error across 6 cycles	tERR(6per)	- 155	155	ps
Cumulative error across 7 cycles	tERR(7per)	- 163	163	ps
Cumulative error across 8 cycles	tERR(8per)	- 169	169	ps
Cumulative error across 9 cycles	tERR(9per)	- 175	175	ps
Cumulative error across 10 cycles	tERR(10per)	- 180	180	ps

11.2 AC Timing Parameters & Specifications (con't)

Parameter	Symbol	DDR3-1600		Units
		min	max	
Cumulative error across 11 cycles	tERR(11per)	- 184	184	ps
Cumulative error across 12 cycles	tERR(12per)	- 188	188	ps
Cumulative error across n = 13, 14 ... 49, 50 cycles	tERR(nper)	tERR(nper)min = (1 + 0.68ln(n))*tJIT(per)min tERR(nper)max = (1 = 0.68ln(n))*tJIT(per)max		ps
Absolute clock HIGH pulse width	tCH(abs)	0.43	-	tCK(avg)
Absolute clock Low pulse width	tCL(abs)	0.43	-	tCK(avg)
Data Timing				
DQS, /DQS to DQ skew, per group, per access	tDQSQ	-	100	ps
DQ output hold time from DQS, /DQS	tQH	0.38	-	tCK(avg)
DQ low-impedance time from CK, /CK	tLZ(DQ)	-450	225	ps
DQ high-impedance time from CK, /CK	tHZ(DQ)	-	225	ps
Data setup time to DQS, /DQS referenced to Vih(ac)Vil(ac) levels	tDS(base) AC175	TBD	-	ps
	tDS(base) AC150	10	-	ps
Data hold time to DQS, /DQS referenced to Vih(ac)Vil(ac) levels	tDH(base) DC100	45	-	ps
DQ and DM Input pulse width for each input	tDIPW	360	-	ps
Data Strobe Timing				
DQS, /DQS READ Preamble	tRPRE	0.9	-	tCK
DQS, /DQS differential READ Postamble	tRPST	0.3	-	tCK
DQS, /DQS output high time	tQSH	0.4	-	tCK(avg)
DQS, /DQS output low time	tQSL	0.4	-	tCK(avg)
DQS, /DQS WRITE Preamble	tWPRE	0.9	-	tCK
DQS, /DQS WRITE Postamble	tWPST	0.3	-	tCK
DQS, /DQS rising edge output access time from rising CK, /CK	tDQSCK	-225	225	ps
DQS, /DQS low-impedance time (Referenced from RL-1)	tLZ(DQS)	-450	225	ps
DQS, /DQS high-impedance time (Referenced from RL+BL/2)	tHZ(DQS)	-	225	ps
DQS, DQS differential input low pulse width	tDQSL	0.45	0.55	tCK
DQS, DQS differential input high pulse width	tDQSH	0.45	0.55	tCK
DQS, DQS rising edge to CK, /CK rising edge	tDQSS	-0.27	0.27	tCK(avg)
DQS,DQS falling edge setup time to CK, /CK rising edge	tDSS	0.18	-	tCK(avg)
DQS,DQS falling edge hold time to CK, /CK rising edge	tDSH	0.18	-	tCK(avg)
DLL locking time	tDLLK	512	-	nCK
internal READ Command to PRECHARGE Command delay	tRTP	max (4tCK,7.5ns)	-	
Delay from start of internal write transaction to internal read command	tWTR	max (4tCK,7.5ns)	-	
WRITE recovery time	tWR	15	-	ns
Mode Register Set command cycle time	tMRD	4	-	nCK
Mode Register Set command update delay	tMOD	max (12tCK,15ns)	-	
CAS# to CAS# command delay	tCCD	4	-	nCK
Auto precharge write recovery + precharge time	tDAL(min)	WR + roundup (tRP / tCK(AVG))		nCK

11.3 AC Timing Parameters & Specifications (con't)

Parameter	Symbol	DDR3-1600		Units
		min	max	
Multi-Purpose Register Recovery Time	tMPRR	1	-	nCK
ACTIVE to PRECHARGE command period	tRAS	36	70,000	ns
ACTIVE to ACTIVE command period for 1KB page size	tRRD	max (4tCK,6ns)	-	
ACTIVE to ACTIVE command period for 2KB page size	tRRD	max (4tCK,7.5ns)	-	
Four activate window for 1KB page size	tFAW	30	-	ns
Four activate window for 2KB page size	tFAW	40	-	ns
Command and Address setup time to CK, /CK referenced to Vih(ac) / Vil(ac) levels	tIS(base) AC175	45	-	ps
	tIS(base) AC150	45+125	-	ps
Command and Address hold time from CK, /CK referenced to Vih(ac) / Vil(ac) levels	tIH(base) DC100	120	-	ps
Control & Address Input pulse width for each input	tIPW	560	-	ps
Calibration Timing				
Power-up and RESET calibration time	tZQinitl	512	-	tCK
Normal operation Full calibration time	tZQoper	256	-	tCK
Normal operation short calibration time	tZQCS	64	-	tCK
Reset Timing				
Exit Reset from CKE HIGH to a valid command	tXPR	max(5tCK, tRFC+ 10ns)	-	
Self Refresh Timing				
Exit Self Refresh to commands not requiring a locked DLL	tXS	max(5tCK, tRFC+ 10ns)	-	
Exit Self Refresh to commands requiring a locked DLL	tXSDLL	tDLLK(min)	-	nCK
Minimum CKE low width for Self refresh entry to exit timing	tCKESR	tCKE(min) + 1tCK	-	
Valid Clock Requirement after Self Refresh Entry (SRE)	tCKSRE	max(5tCK, 10ns)	-	
Valid Clock Requirement before Self Refresh Exit (SRX)	tCKSRX	max(5tCK, 10ns)	-	
Power Down Timing				
Exit Power Down with DLL on to any valid command; Exit Precharge Power Down with DLL frozen to commands not requiring a locked DLL	tXP	max (3tCK,6ns)	-	
Exit Precharge Power Down with DLL frozen to commands requiring a locked DLL	tXPDLL	max(10tCK, 24ns)	-	
CKE minimum pulse width	tCKE	max(3tCK, 5 ns)	-	
Command pass disable delay	tCPDED	1	-	nCK
Power Down Entry to Exit Timing	tPD	tCKE(min)	9*tREFI	tCK
Timing of ACT command to Power Down entry	tACTPDEN	1	-	nCK
Timing of PRE command to Power Down entry	tPRPDEN	1	-	nCK
Timing of RD/RDA command to Power Down entry	tRDPDEN	RL + 4 + 1	-	
Timing of WR command to Power Down entry (BL8OTF, BL8MRS, BL4OTF)	tWRPDEN	WL + 4 + (tWR/tCK)	-	nCK
Timing of WRA command to Power Down entry (BL8OTF, BL8MRS, BL4OTF)	tWRAPDEN	WL + 4 + WR + 1	-	nCK
Timing of WR command to Power Down entry (BL4MRS)	tWRPDEN	WL + 2 + (tWR/ tCK(avg))	-	nCK

11.4 AC Timing Parameters & Specifications (con't)

Parameter	Symbol	DDR3-1600		Units
		min	max	
Timing of WRA command to Power Down entry (BL4MRS)	tWRAPDEN	WL +2 +WR +1	-	nCK
Timing of REF command to Power Down entry	tREFPDEN	1	-	
Timing of MRS command to Power Down entry	tMRSPDEN	tMOD(min)	-	
ODT Timing				
ODT high time without write command or with write command and BC4	ODTH4	4	-	nCK
ODT high time with Write command and BL8	ODTH8	6	-	nCK
Asynchronous RTT turn-on delay (Power-Down with DLL frozen)	tAONPD	2	8.5	ns
Asynchronous RTT turn-off delay (Power-Down with DLL frozen)	tAOFPD	2	8.5	ns
ODT turn-on	tAON	-225	225	ps
RTT_NOM and RTT_WR turn-off time from ODTL off reference	tAOF	0.3	0.7	tCK(avg)
RTT dynamic change skew	tADC	0.3	0.7	tCK(avg)
Write Leveling Timing				
First DQS pulse rising edge after tDQSS margining mode is programmed	tWLMRD	40	-	tCK
DQS/DQS delay after tDQS margining mode is programmed	tWLDQSEN	25	-	tCK
Setup time for tDQSS latch	tWLS	165	-	ps
Hold time of tDQSS latch	tWLH	165	-	ps
Write leveling output delay	tWLO	0	7.5	ns
Write leveling output error	tWLOE	0	2	ns

240-Pin VLP-Unbuffered DIMM

DDR3 SDRAM

12.0 Physical Dimensions: (256Mbx8 Based, 512Mx64, 2 ranks)

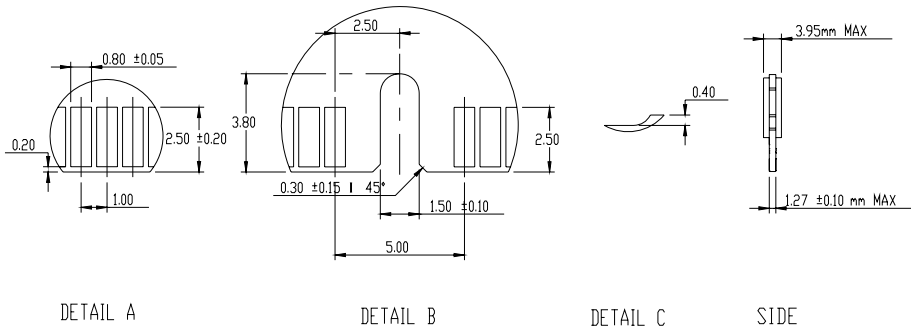
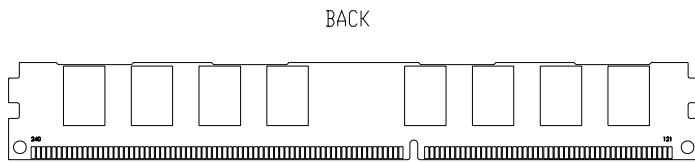
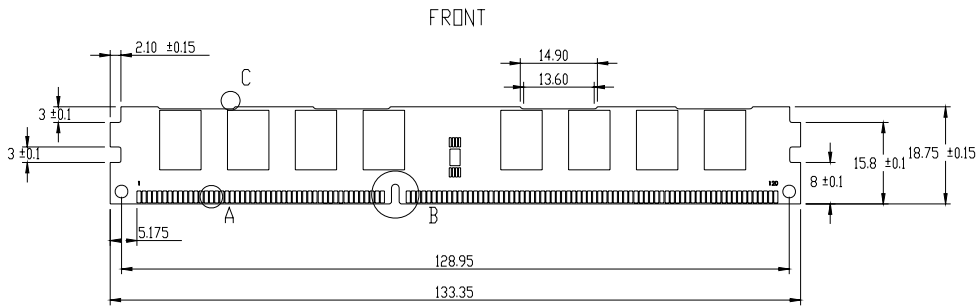

TOLERANCES: ± 0.005(.13) UNLESS OTHERWISE SPECIFIED

Tolerances :± 0.005(.13) unless otherwise specified