

DDR3 SODIMM Module

4GB based on 2Gbit component

TFBGA with Pb-Free



Revision 1.0 (May, 2007)
-Initial Release

1.0 Feature

- JEDEC standard 1.5V ± 0.075V Power Supply
- VDDQ = 1.5V ± 0.075V
- Programmable CAS Latency: 5,6,7,8,9,10,11,13
- Programmable Additive Latency(Posted CAS) : 0, CL - 2, or CL - 1 clock
- Programmable CAS Write Latency(CWL) = 5 (DDR3-800), 6 (DDR3-1066), 7 (DDR3-1333), 8 (DDR3-1600) and 9 (DDR3-1866)
- Bi-directional Differential Data Strobe
- Burst Length: 8 (Interleave without any limit, sequential with starting address “000” only), 4 with tCCD = 4 which does not allow seamless read or write [either On the fly using A12 or MRS]
- On-Die termination using ODT pin
- 8 independent internal bank
- 400MHz fCK for 800Mb/sec/pin, 533MHz fCK for 1066Mb/sec/pin, 667MHz fCK for 1333Mb/sec/pin, 800MHz fCK for 1600Mb/sec/pin, 900MHz fCK for 1866Mb/sec/pin
- Asynchronous Reset
- Burst Length: 8 (Interleave without any limit, sequential with starting address “000” only), 4 with tCCD = 4 which does not allow seamless read or write [either On the fly using A12 or MRS]
- Average Refresh Period 7.8us at lower than a TCASE 85°C, 3.9us at 85°C < TCASE < 95 °C
- Serial presence detect with EEPROM
- DIMM Dimension (Nominal) 30.00 mm high, 67.60 mm wide
- Based on JEDEC standard reference Raw Cards Lay out.
- RoHS compliant
- Gold plated contacts

2.0 Ordering Information

Part number	Density	Module Organization	Component composition	Component PKG	Module Rank	Description
W1333SB4Gx	4GB	512Mx64	256Mx8*16	TFBGA	2	4GB 2Rx8 PC3-10600U

Note: Last Character of the Part Number stand for DRAM vendor
S=Samsung; M=Micron; H=Hynix

3.0 Key Timing Parameters

	DDR3-800	DDR3-1066	DDR3-1333	DDR3-1600	DDR3-1866	Unit
CL-tRCD-tRP	6-6-6	7-7-7	9-9-9	11-11-11	13-13-13	tCK
CAS Latency	6	7	9	11	13	tCK
tCK(min)	2.5	1.875	1.5	1.25	1.07	ns
tRCD(min)	15	13.25	13.5	13.75	13.91	ns
tRP(min)	15	13.25	13.5	13.75	13.91	ns
tRAS(min)	37.5	37.5	36	35	34	ns
tRC(min)	52.5	50.625	49.5	48.75	47.91	ns

4.0 Absolute Maximum DC Rating

Symbol	Parameter	Rating	Units
V _{in} , V _{out}	Voltage on any pin relative to V _{SS}	-0.4 ~ 1.975	V
V _{DD}	Voltage on V _{DD} & V _{DDQ} supply relative to V _{SS}	-0.4 ~ 1.975	V
V _{DDQ}	Short circuit current	-0.4 ~ 1.975	V
V _{DDL}	Power dissipation	-0.4 ~ 1.975	V
T _{STG}	Storage Temperature	-55 ~ + 100	°C

5.0 DIMM Pin Configurations (Front side/Back side)

Pin	Front	Pin	Back	Pin	Front	Pin	Back	Pin	Front	Pin	Back
1	V _{REF} DQ	2	V _{SS}	71	V _{SS}	72	V _{SS}	139	V _{SS}	140	DQ38
3	V _{SS}	4	DQ4	KEY				141	DQ34	142	DQ39
5	DQ0	6	DQ5	73	CKE0	74	CKE1	143	DQ35	144	V _{SS}
7	DQ1	8	V _{SS}	75	V _{DD}	76	V _{DD}	145	V _{SS}	146	DQ44
9	V _{SS}	10	/DQS0	77	NC	78	A15	147	DQ40	148	DQ45
11	DM0	12	DQS0	79	BA2	80	A14	149	DQ41	150	V _{SS}
13	V _{SS}	14	V _{SS}	81	V _{DD} _____	82	V _{DD}	151	V _{SS}	152	/DQS5
15	DQ2	16	DQ6	83	A12/BC	84	A11	153	DM5	154	DQS5
17	DQ3	18	DQ7	85	A9	86	A7	155	V _{SS}	156	V _{SS}
19	V _{SS}	20	V _{SS}	87	V _{DD}	88	V _{DD}	157	DQ42	158	DQ46
21	DQ8	22	DQ12	89	A8	90	A6	159	DQ43	160	DQ47
23	DQ9	24	DQ13	91	A5	92	A4	161	V _{SS}	162	V _{SS}
25	V _{SS}	26	V _{SS}	93	V _{DD}	94	V _{DD}	163	DQ48	164	DQ52
27	/DQS1	28	DM1	95	A3	96	A2	165	DQ49	166	DQ53
29	DQS1	30	/RESET	97	A1	98	A0	167	V _{SS}	168	V _{SS}
31	V _{SS}	32	V _{SS}	99	V _{DD}	100	V _{DD}	169	/DQS6	170	DM6
33	DQ10	34	DQ14	101	/CK0	102	CK1	171	DQS6	172	V _{SS}
35	DQ11	36	DQ15	103	CK0	104	/CK1	173	V _{SS}	174	DQ54
37	V _{SS}	38	V _{SS}	105	V _{DD}	106	V _{DD}	175	DQ50	176	DQ55
39	DQ16	40	DQ20	107	A10/AP	108	BA1	177	DQ51	178	V _{SS}
41	DQ17	42	DQ21	109	BA0	110	/RAS	179	V _{SS}	180	DQ60
43	V _{SS}	44	V _{SS}	111	V _{DD}	112	V _{DD}	181	DQ56	182	DQ61
45	/DQS2	46	DM2	113	/WE	114	/S0	183	DQ57	184	V _{SS}
47	DQS2	48	V _{SS}	115	/CAS	116	ODT0	185	V _{SS}	186	/DQS7
49	V _{SS}	50	DQ22	117	V _{DD}	118	V _{DD}	187	DM7	188	DQS7
51	DQ18	52	DQ23	119	A13	120	ODT1	189	V _{SS}	190	V _{SS}
53	DQ19	54	V _{SS}	121	/S1	122	NC	191	DQ58	192	DQ62
55	V _{SS}	56	DQ28	123	V _{DD}	124	V _{DD}	193	DQ59	194	DQ63
57	DQ24	58	DQ29	125	TEST	126	V _{REF} CA	195	V _{SS}	196	V _{SS}
59	DQ25	60	V _{SS}	127	V _{SS}	128	V _{SS}	197	SA0	198	NC
61	V _{SS}	62	/DQS3	129	DQ32	130	DQ36	199	V _{DD} SPD	200	SDA
63	DM3	64	DQS3	131	DQ33	132	DQ37	201	SA1	202	SCL
65	V _{SS}	66	V _{SS}	133	V _{SS}	134	V _{SS}	203	V _{tt}	204	V _{tt}
67	DQ26	68	DQ30	135	/DQS4	136	DM4				
69	DQ27	70	DQ31	137	DQS4	138	V _{SS}				

NC = No Connect, RFU = Reserved for Future Use

6.0 DIMM Pin Description

Pin Name	Function	Pin Name	Function
A0 ~ A15	Address input (Multiplexed)	ODT0~ODT1	On Die Termination
A10/AP	Address Input/Auto pre-charge	CB0~CB7	ECC Data check bits Input/Output
BA0 ~ BA2	Bank Select	DQ0~DQ63	Data Input/Output
$\overline{\text{CK0}} \sim \overline{\text{CK2}}, \overline{\text{CK0}} \sim \overline{\text{CK2}}$	Clock input	$\overline{\text{DQS0}} \sim \overline{\text{DQS8}}$	Data strobes, negative line
CKE0, CKE1	Clock enable input	DM(0~8),	Data Masks/Data strobes (Read)
$\overline{\text{S0}}, \overline{\text{S1}}$	Chip select input	DQS0~DQS8	Data Strobes
$\overline{\text{RAS}}$	Row address strobe	RFU	Reserved for future used
$\overline{\text{CAS}}$	Column address strobe	V _{TT}	SDRAM I/O termination power supply
$\overline{\text{WE}}$	Write Enable	TEST	Memory bus test tool
SCL	SPD Clock Input	V _{DD}	Core Power
SDA	SPD Data Input/Output	V _{DDQ}	I/O Power
SA0~SA2	SPD Address	V _{SS}	Ground
Par_In	Parity bit for address & Control bus	V _{REFDQ}	SDRAM Input/Output Reference Supply
Err_Out	Parity error found in the Address and Control bus	V _{DDSPD}	Serial EEPROM Power Supply
Reset	Register and PLL control pin	V _{REFCA}	Command Address Reference Supply

7.0 Address Configuration

Organization	Row Address	Column Address	Bank Address	Auto Pre-charge
256Mx8(2Gb) base	A0-A14	A0-A9	BA0-BA2	A10/AP

8.0 Functional Block Diagram: 4GB, 512Mx64 Module (Populated as 2 rank of x8)

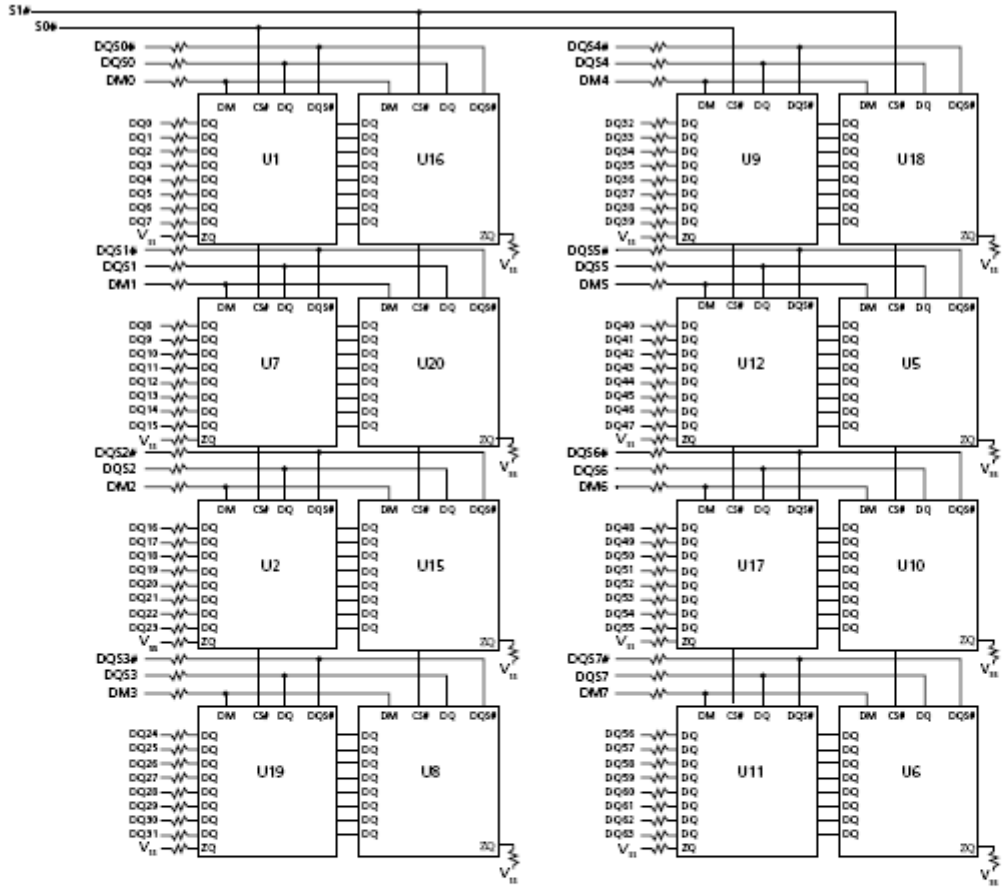

Rank 0 = U1, U2, U7, U9, U11, U12, U17, U19
Rank 1 = U5, U6, U8, U10, U15, U16, U18, U20

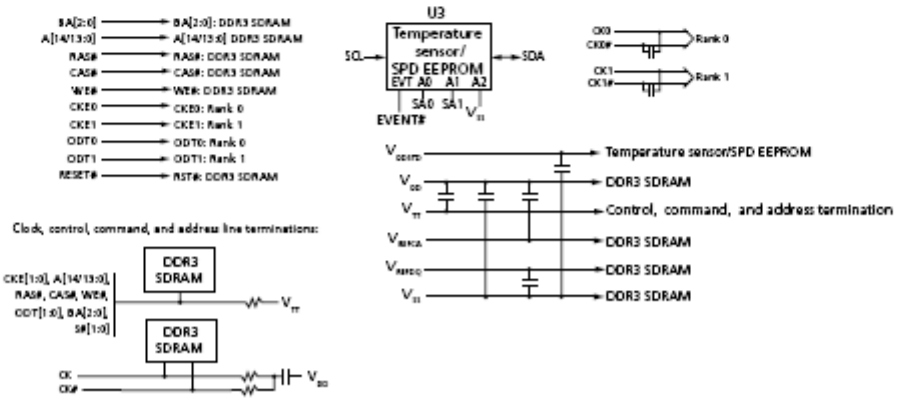

Note: 1. The ZQ ball on each DDR3 component is connected to an external $240\Omega \pm 1\%$ resistor that is tied to ground. It is used for the calibration of the component's ODT and output driver.

9.0 AC & DC Operating Conditions

Recommended operating conditions (Voltage referenced to V_{SS}=0V, TA=0 to 70°C)

Symbol	Parameter	Min	Typ	Max	Unit
V _{DD}	Supply Voltage	1.425	1.5	1.575	V
V _{DDQ}	Supply Voltage for Output	1.425	1.5	1.575	V
V _{REFDQ(DC)}	I/O Reference Voltage (DQ)	0.49*V _{DDQ}	0.50*V _{DDQ}	0.51*V _{DDQ}	V
V _{REFCA(DC)}	I/O Reference Voltage (CMD/Add)	0.49*V _{DDQ}	0.50*V _{DDQ}	0.51*V _{DDQ}	V
V _{TT}	Termination Voltage	0.49*V _{DDQ}	0.50*V _{DDQ}	0.51*V _{DDQ}	V

10.0 Capacitance (Max.)

Symbol	Parameter/Condition	Min	Max	Unit
CCK	Input capacitance, CK and \overline{CK}	-	11	pF
CI1	Input capacitance, CKE and \overline{CS}	-	12	pF
CI2	Input capacitance, Addr, RAS, CAS, \overline{WE}	-	12	pF
CIO	Input capacitance, DQ, DM, DQS, \overline{DQS}	-	10	pF

11.1 AC Timing Parameters & Specifications

(AC operating conditions unless otherwise noted)

Parameter	Symbol	DDR3-1333		Units
		min	max	
Minimum Clock Cycle Time (DLL off mode)	tCK(DLL_OFF)	8	-	ns
Average Clock Period	tCK(avg)	-		ps
Clock Period	tCK(abs)	tCK(avg) min +tJIT (per)min	tCK(avg) max +tJIT (per)max	ps
Average high pulse width	tCH(avg)	0.47	0.53	tCK(avg)
Average low pulse width	tCL(avg)	0.47	0.53	tCK(avg)
Clock Period Jitter	tJIT(per)	-80	80	ps
Clock Period Jitter during DLL locking period	tJIT(per, lck)	-80	80	ps
Cycle to Cycle Period Jitter	tJIT(cc)	160	-	ps
Cycle to Cycle Period Jitter during DLL locking period	tJIT(cc, lck)	140	-	ps
Cumulative error across 2 cycles	tERR(2per)	- 118	118	ps
Cumulative error across 3 cycles	tERR(3per)	- 140	140	ps
Cumulative error across 4 cycles	tERR(4per)	- 155	155	ps
Cumulative error across 5 cycles	tERR(5per)	- 168	168	ps
Cumulative error across 6 cycles	tERR(6per)	- 177	177	ps
Cumulative error across 7 cycles	tERR(7per)	- 186	186	ps
Cumulative error across 8 cycles	tERR(8per)	- 193	193	ps
Cumulative error across 9 cycles	tERR(9per)	- 200	200	ps
Cumulative error across 10 cycles	tERR(10per)	- 205	205	ps

11.2 AC Timing Parameters & Specifications (con't)

Parameter	Symbol	DDR3-1333		Units
		min	max	
Cumulative error across 11 cycles	tERR(11per)	- 210	210	ps
Cumulative error across 12 cycles	tERR(12per)	- 215	215	ps
Cumulative error across n = 13, 14 ... 49, 50 cycles	tERR(nper)	tERR(nper)min = (1 + 0.68ln(n))*tJIT(per)min tERR(nper)max = (1 - 0.68ln(n))*tJIT(per)max		ps
Absolute clock HIGH pulse width	tCH(abs)	0.43	-	tCK(avg)
Absolute clock Low pulse width	tCL(abs)	0.43	-	tCK(avg)
Data Timing				
DQS, /DQS to DQ skew, per group, per access	tDQSQ	-	125	ps
DQ output hold time from DQS, /DQS	tQH	0.38	-	tCK(avg)
DQ low-impedance time from CK, /CK	tLZ(DQ)	-500	250	ps
DQ high-impedance time from CK, /CK	tHZ(DQ)	-	250	ps
Data setup time to DQS, /DQS referenced to Vih(ac)/Vil(ac) levels	tDS(base)	TBD	-	ps
Data hold time to DQS, /DQS referenced to Vih(ac)/Vil(ac) levels	tDH(base)	TBD	-	ps
DQ and DM Input pulse width for each input	tDIPW	400	-	ps
Data Strobe Timing				
DQS, /DQS READ Preamble	tRPRE	0.9	-	tCK
DQS, /DQS differential READ Postamble	tRPST	0.3	-	tCK
DQS, /DQS output high time	tQSH	0.4	-	tCK(avg)
DQS, /DQS output low time	tQSL	0.4	-	tCK(avg)
DQS, /DQS WRITE Preamble	tWPRE	0.9	-	tCK
DQS, /DQS WRITE Postamble	tWPST	0.3	-	tCK
DQS, /DQS rising edge output access time from rising CK, /CK	tDQSCK	-255	255	ps
DQS, /DQS low-impedance time (Referenced from RL-1)	tLZ(DQS)	-500	250	ps
DQS, /DQS high-impedance time (Referenced from RL+BL/2)	tHZ(DQS)	250	-	ps
DQS, DQS differential input low pulse width	tDQSL	0.45	0.55	tCK
DQS, DQS differential input high pulse width	tDQSH	0.45	0.55	tCK
DQS, DQS rising edge to CK, CK rising edge	tDQSS	-0.25	0.25	tCK(avg)
DQS,DQS falling edge setup time to CK, CK rising edge	tDSS	0.2	-	tCK(avg)
DQS,DQS falling edge hold time to CK, CK rising edge	tDSH	0.2	-	tCK(avg)
DLL locking time	tDLLK	512	-	nCK
internal READ Command to PRECHARGE Command delay	tRTP	max (4tCK,7.5ns)	-	
Delay from start of internal write transaction to internal read command	tWTR	max (4tCK,7.5ns)	-	
WRITE recovery time	tWR	15	-	ns
Mode Register Set command cycle time	tMRD	4	-	nCK
Mode Register Set command update delay	tMOD	max (12tCK,15ns)	-	
CAS# to CAS# command delay	tCCD	4	-	nCK
Auto precharge write recovery + precharge time	tDAL(min)	WR + roundup (tRP / tCK(AVG))		nCK

11.3 AC Timing Parameters & Specifications (con't)

Parameter	Symbol	DDR3-1333		Units
		min	max	
Multi-Purpose Register Recovery Time	tMPRR	1	-	nCK
ACTIVE to PRECHARGE command period	tRAS	36	70,000	ns
ACTIVE to ACTIVE command period for 1KB page size	tRRD	max(4tCK,6ns)	-	
ACTIVE to ACTIVE command period for 2KB page size	tRRD	max(4tCK,7.5ns)	-	
Four activate window for 1KB page size	tFAW	30	-	ns
Four activate window for 2KB page size	tFAW	45	-	ns
Command and Address setup time to CK, CK referenced to Vih(ac) / Vil(ac) levels	tIS(base)	65	-	ps
Command and Address hold time from CK, CK referenced to Vih(ac) / Vil(ac) levels	tIH(base)	140	-	ps
Command and Address setup time to CK, CK referenced to Vih(ac) / Vil(ac) levels	tIS(base)AC150	65+125	-	ps
Control & Address Input pulse width for each input	tIPW	620	-	ps
Calibration Timing				
Power-up and RESET calibration time	tZQinitl	512	-	tCK
Normal operation Full calibration time	tZQoper	256	-	tCK
Normal operation short calibration time	tZQCS	64	-	tCK
Reset Timing				
Exit Reset from CKE HIGH to a valid command	tXPR	max(5tCK, tRFC+10ns)	-	
Self Refresh Timing				
Exit Self Refresh to commands not requiring a locked DLL	tXS	max(5tCK,tRFC+ 10ns)	-	
Exit Self Refresh to commands requiring a locked DLL	tXSDLL	tDLLK(min)	-	nCK
Minimum CKE low width for Self refresh entry to exit timing	tCKESR	tCKE(min) + 1tCK	-	
Valid Clock Requirement after Self Refresh Entry (SRE)	tCKSRE	max(5tCK, 10ns)	-	
Valid Clock Requirement before Self Refresh Exit (SRX)	tCKSRX	max(5tCK, 10ns)	-	
Power Down Timing				
Exit Power Down with DLL on to any valid command; Exit Precharge Power Down with DLL frozen to commands not requiring a locked DLL	tXP	max(3tCK,6ns)	-	
Exit Precharge Power Down with DLL frozen to commands requiring a locked DLL	tXPDLL	max(10tCK, 24ns)	-	
CKE minimum pulse width	tCKE	max(3tCK, 5.625ns)	-	
Command pass disable delay	tCPDED	1	-	nCK
Power Down Entry to Exit Timing	tPD	tCKE(min)	9*tREFI	tCK
Timing of ACT command to Power Down entry	tACTPDEN	1	-	nCK
Timing of PRE command to Power Down entry	tPRPDEN	1	-	nCK
Timing of RD/RDA command to Power Down entry	tRDPDEN	RL + 4 + 1	-	
Timing of WR command to Power Down entry (BL8OTF, BL8MRS, BL4OTF)	tWRPDEN	WL + 4 +(tWR/tCK)	-	nCK
Timing of WRA command to Power Down entry (BL8OTF, BL8MRS, BL4OTF)	tWRAPDEN	WL + 4 +WR+1	-	nCK
Timing of WR command to Power Down entry (BL4MRS)	tWRPDEN	WL + 2 +(tWR/tCK(avg))	-	nCK

11.4 AC Timing Parameters & Specifications (con't)

Parameter	Symbol	DDR3-1333		Units
		min	max	
Timing of WRA command to Power Down entry (BL4MRS)	tWRAPDEN	WL +2 +WR +1	-	nCK
Timing of REF command to Power Down entry	tREFPDEN	1	-	
Timing of MRS command to Power Down entry	tMRSPDEN	tMOD(min)	-	
ODT Timing				
ODT high time without write command or with write command and BC4	ODTH4	4	-	nCK
ODT high time with Write command and BL8	ODTH8	6	-	nCK
Asynchronous RTT turn-on delay (Power-Down with DLL frozen)	tAONPD	1	9	ns
Asynchronous RTT turn-off delay (Power-Down with DLL frozen)	tAOFPD	1	9	ns
ODT turn-on	tAON	-250	250	ps
RTT_NOM and RTT_WR turn-off time from ODTL off reference	tAOF	0.3	0.7	tCK(avg)
RTT dynamic change skew	tADC	0.3	0.7	tCK(avg)
Write Leveling Timing				
First DQS pulse rising edge after tDQSS margining mode is programmed	tWLMRD	40	-	tCK
DQS/DQS delay after tDQS margining mode is programmed	tWLDQSEN	25	-	tCK
Setup time for tDQSS latch	tWLS	195	-	ps
Hold time of tDQSS latch	tWLH	195	-	ps
Write leveling output delay	tWLO	0	9	ns
Write leveling output error	tWLOE	0	2	ns

12.0 Physical Dimensions: (256Mbx8 Based, 512MBx64, 2 Rank)

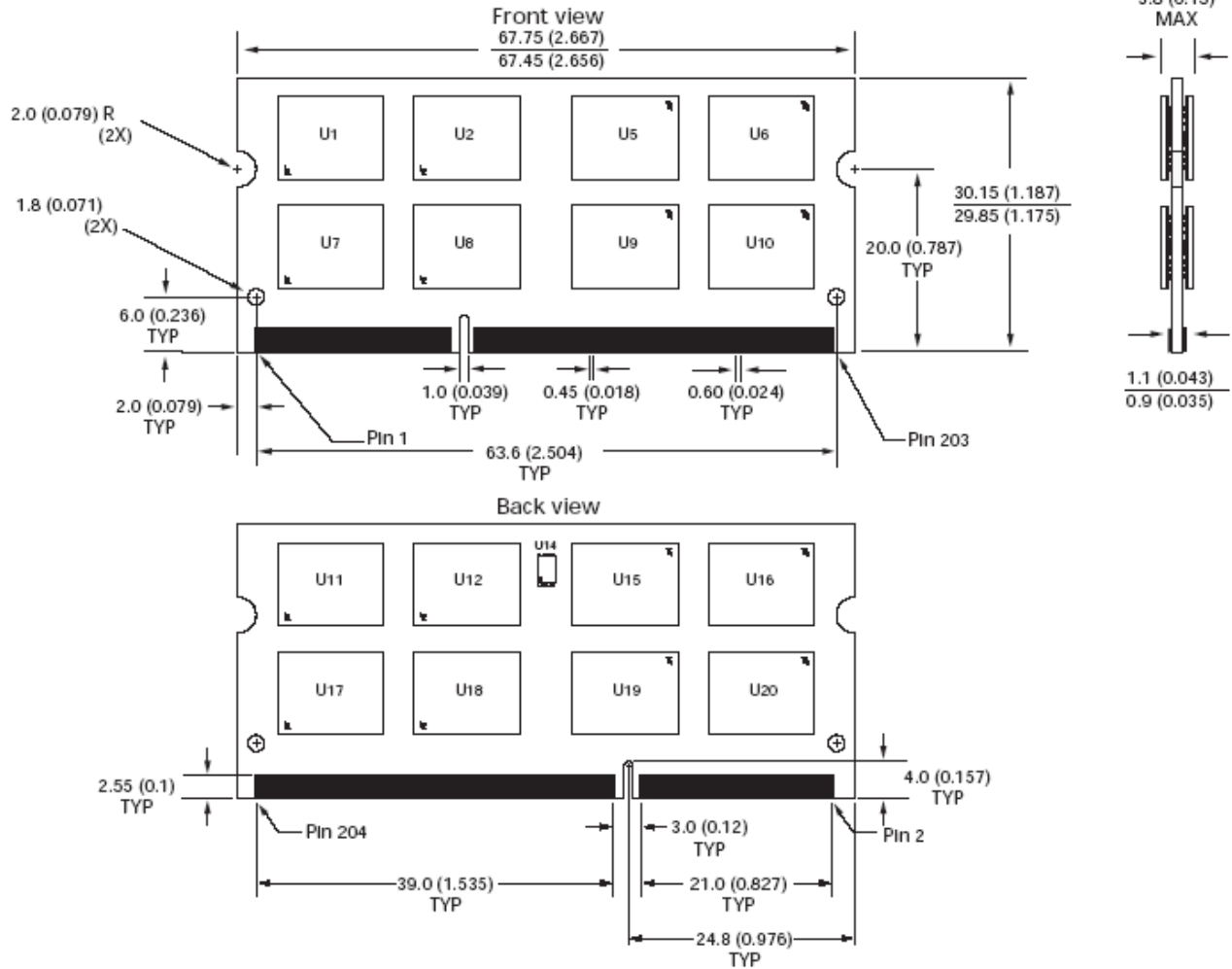

Units: Millimeter
Tolerances: ± 0.13) unless otherwise specified