

# **DDR3 Unbuffered DIMM Module**

**8GB based on 4Gbit component**

**TFBGA with Pb-Free**



**Revision 1.0 (MAY. 2007)**  
-Initial Release

**1.0 Feature**

- JEDEC standard 1.5V ± 0.075V Power Supply
- VDDQ = 1.5V ± 0.075V
- Programmable CAS latencies 6,7,8,9,10,11,13
- Programmable Additive Latency(Posted CAS) : 0, CL - 2, or CL - 1 clock
- Programmable CAS Write Latency(CWL) = 5 (DDR3-800), 6 (DDR3-1066), 7 (DDR3-1333), 8 (DDR3-1600) and 9 (DDR3-1866)
- 400MHz fCK for 800Mb/sec/pin, 533MHz fCK for 1066Mb/sec/pin, 667MHz fCK for 1333Mb/sec/pin, 800MHz fCK for 1600Mb/sec/pin, 900MHz fCK for 1866Mb/sec/pin
- Bi-directional Differential Data Strobe
- Burst Length: 8 (Interleave without any limit, sequential with starting address “000” only), 4 with tCCD = 4 which does not allow seamless read or write [either On the fly using A12 or MRS]
- On-Die termination using ODT pin
- 8 independent internal bank
- Asynchronous Reset
- Average Refresh Period 7.8us at lower than a TCASE 85°C, 3.9us at 85°C < TCASE < 95 °C
- Serial presence detect with EEPROM
- DIMM Dimension (Nominal) 30.00 mm high, 133.35 mm wide
- Based on JEDEC standard reference Raw Cards Lay out.
- RoHS compliant
- Gold plated contacts

**2.0 Ordering Information**

Part number	Density	Module Organization	Component composition	Component PKG	Module Rank	Description
W1600UB8Gx	8GB	1Gx64	512Mx8*16	TFBGA	2	8GB 2Rx8 PC3-12800

Note: Last Character x of the Part Number stand for DRAM vendor  
S=Samsung; M=Micron; H=Hynix

**3.0 Key Timing Parameters**

	DDR3-1600	Unit
CL-tRCD-tRP	11-11-11	tCK
CAS Latency	11	nCK
tCK(min)	1.25	ns
tRCD(min)	13.5	ns
tRP(min)	13.5	ns
tRAS(min)	35	ns
tRC(min)	48.75	ns

**4.0 Absolute Maximum DC Rating**

Symbol	Parameter	Rating	Units
V <sub>in</sub> , V <sub>out</sub>	Voltage on any pin relative to V <sub>SS</sub>	-0.4 ~ 1.975	V
V <sub>DD</sub>	Voltage on V <sub>DD</sub> & V <sub>DDQ</sub> supply relative to V <sub>SS</sub>	-0.4 ~ 1.975	V
V <sub>DDQ</sub>	Short circuit current	-0.4 ~ 1.975	V
V <sub>DDL</sub>	Power dissipation	-0.4 ~ 1.975	V
T <sub>STG</sub>	Storage Temperature	-55 ~ + 100	°C

**5.0 DIMM Pin Configurations (Front side/Back side)**

Pin	Front	Pin	Back	Pin	Front	Pin	Back	Pin	Front	Pin	Back
1	V <sub>REF</sub> DQ	121	V <sub>SS</sub>	41	V <sub>SS</sub>	161	DM8/DQS17_P	81	DQ32	201	DQ37
2	V <sub>SS</sub>	122	DQ4	42	NC	162	DQS17_N	82	DQ33	202	V <sub>SS</sub>
3	DQ0	123	DQ5	43	NC	163	V <sub>SS</sub>	83	V <sub>SS</sub>	203	DM4/DQS13_P
4	DQ1	124	V <sub>SS</sub>	44	V <sub>SS</sub>	164	NC	84	DQS4_N	204	DQS13_N
5	V <sub>SS</sub>	125	DM0/DQS9_P	45	NC	165	NC	85	DQS4_P	205	V <sub>SS</sub>
6	DQS0_N	126	NC/DQS9_N	46	NC	166	V <sub>SS</sub>	86	V <sub>SS</sub>	206	DQ38
7	DQS0_P	127	V <sub>SS</sub>	47	V <sub>SS</sub>	167	NC/TEST	87	DQ34	207	DQ39
8	V <sub>SS</sub>	128	DQ6	48	NC	168	RESET_N	88	DQ35	208	V <sub>SS</sub>
9	DQ2	129	DQ7	KEY				89	V <sub>SS</sub>	209	DQ44
10	DQ3	130	V <sub>SS</sub>	49	NC	169	CKE1	90	DQ40	210	DQ45
11	V <sub>SS</sub>	131	DQ12	50	CKE0	170	VDD	91	DQ41	211	V <sub>SS</sub>
12	DQ8	132	DQ13	51	VDD	171	A15	92	V <sub>SS</sub>	212	DM5/DQS14_P
13	DQ9	133	V <sub>SS</sub>	52	BA2	172	A14	93	DQS5_N	213	DQS14_N
14	V <sub>SS</sub>	134	DM1/DQS10_P	53	NC/Err-Out	173	VDD	94	DQS5_P	214	V <sub>SS</sub>
15	DQS1_N	135	DQS10_N	54	VDD	174	A12	95	V <sub>SS</sub>	215	DQ46
16	DQS2_P	136	V <sub>SS</sub>	55	A11	175	A9	96	DQ42	216	DQ47
17	V <sub>SS</sub>	137	DQ14	56	A7	176	VDD	97	DQ43	217	V <sub>SS</sub>
18	DQ10	138	DQ15	57	VDD	177	A8	98	V <sub>SS</sub>	218	DQ52
19	DQ11	139	V <sub>SS</sub>	58	A5	178	A6	99	DQ48	219	DQ53
20	V <sub>SS</sub>	140	DQ20	59	A4	179	VDD	100	DQ49	220	V <sub>SS</sub>
21	DQ16	141	DQ21	60	VDD	180	A3	101	V <sub>SS</sub>	221	DM6_DQS15_P
22	DQ17	142	V <sub>SS</sub>	61	A2	181	A1	102	DQS6_N	222	DQS15_N
23	V <sub>SS</sub>	143	DQS11_P	62	VDD	182	VDD	103	DQS6_P	223	V <sub>SS</sub>
24	DQS2_N	144	DQS11_N	63	CK1_P/NC	183	VDD	104	V <sub>SS</sub>	224	DQ54
25	DQS2_P	145	V <sub>SS</sub>	64	CK1_N/NC	184	CK0_P	105	DQ50	225	DQ55
26	V <sub>SS</sub>	146	DQ22	65	VDD	185	CK0_N	106	DQ51	226	V <sub>SS</sub>
27	DQ18	147	DQ23	66	VDD	186	VDD	107	V <sub>SS</sub>	227	DQ60
28	DQ19	148	V <sub>SS</sub>	67	V <sub>REF</sub> CA	187	NC/EVENT	108	DQ56	228	DQ61
29	V <sub>SS</sub>	149	DQ28	68	NC, Par_In	188	A0	109	DQ57	229	V <sub>SS</sub>
30	DQ24	150	DQ29	69	VDD	189	VDD	110	V <sub>SS</sub>	230	DM7/DQS16_P
31	DQ25	151	V <sub>SS</sub>	70	A10/AP	190	BA1	111	DQS7_N	231	DQS16_N
32	V <sub>SS</sub>	152	DM3/DQS12_P	71	BA0	191	VDD	112	DQS7_P	232	V <sub>SS</sub>
33	DQ3_N	153	DQS12_N	72	VDD	192	RAS_N	113	V <sub>SS</sub>	233	DQ62
34	DQ3_P	154	V <sub>SS</sub>	73	WE	193	S0_N	114	DQ58	234	DQ63
35	V <sub>SS</sub>	155	DQ30	74	CAS	194	VDD	115	DQ59	235	V <sub>SS</sub>
36	DQ26	156	DQ31	75	VDD	195	ODT0	116	V <sub>SS</sub>	236	V <sub>DD</sub> SPD
37	DQ27	157	V <sub>SS</sub>	76	S1	196	A13	117	SA0	237	SA1
38	V <sub>SS</sub>	158	NC	77	ODT1	197	VDD	118	SCL	238	SDA
39	NC	159	NC	78	VDD	198	NC	119	SA2	239	V <sub>SS</sub>
40	NC	160	V <sub>SS</sub>	79	S2/NC	199	V <sub>SS</sub>	120	V <sub>TT</sub>	240	V <sub>TT</sub>
				80	V <sub>SS</sub>	200	DQ36				

NC = No Connect, RFU = Reserved for Future Use

1. Par\_in and Err\_out pins are intended for register control functions.

**6.0 DIMM Pin Description**

Pin Name	Function	Pin Name	Function
A0 ~ A15	Address input (Multiplexed)	ODT0~ODT1	On Die Termination
A10/AP	Address Input/Auto pre-charge	CB0~CB7	ECC Data check bits Input/Output
BA0 ~ BA2	Bank Select	DQ0~DQ63	Data Input/Output
$\overline{\text{CK0}} \sim \overline{\text{CK2}}, \text{CK0} \sim \text{CK2}$	Clock input	$\overline{\text{DQS0}} \sim \overline{\text{DQS8}}$	Data strobes, negative line
CKE0, CKE1	Clock enable input	DM (0~8),	Data Masks/Data strobes (Read)
$\overline{\text{S0}}, \overline{\text{S1}}$	Chip select input	DQS0~DQS8	Data Strobes
$\overline{\text{RAS}}$	Row address strobe	RFU	Reserved for future used
$\overline{\text{CAS}}$	Column address strobe	V <sub>TT</sub>	SDRAM I/O termination power supply
$\overline{\text{WE}}$	Write Enable	TEST	Memory bus test tool
SCL	SPD Clock Input	V <sub>DD</sub>	Core Power
SDA	SPD Data Input/Output	V <sub>DDQ</sub>	I/O Power
SA0~SA2	SPD Address	V <sub>SS</sub>	Ground
Par_In	Parity bit for address & Control bus	V <sub>REFDQ</sub>	SDRAM Input/Output Reference Supply
$\overline{\text{EVENT}}$	EVENT pin on TS/SPD part, Temperature event	V <sub>DDSPD</sub>	Serial EEPROM Power Supply
$\overline{\text{RESET}}$	Register and PLL control pin	V <sub>REFCA</sub>	Command Address Reference Supply

**7.0 Address Configuration**

Organization	Row Address	Column Address	Bank Address	Auto Pre-charge
512Mx8(4Gb) base	A0-A15	A0-A9	BA0-BA2	A10/AP

**240-Pin Unbuffered DIMM**

**DDR3 SDRAM**

**8.0 Functional Block Diagram: 8GB, 1Gx64 Module (Populated as 2 ranks of x8)**

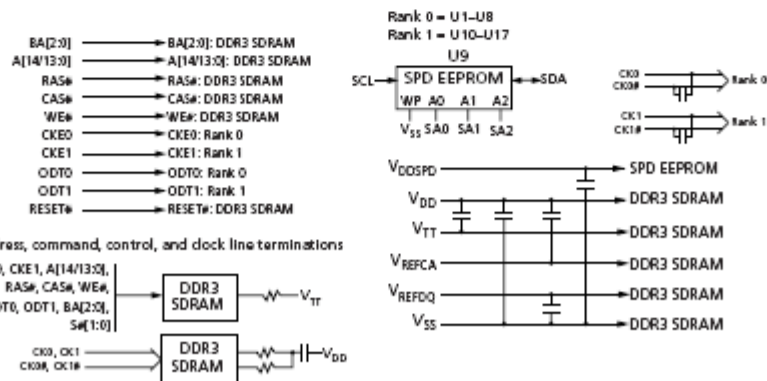
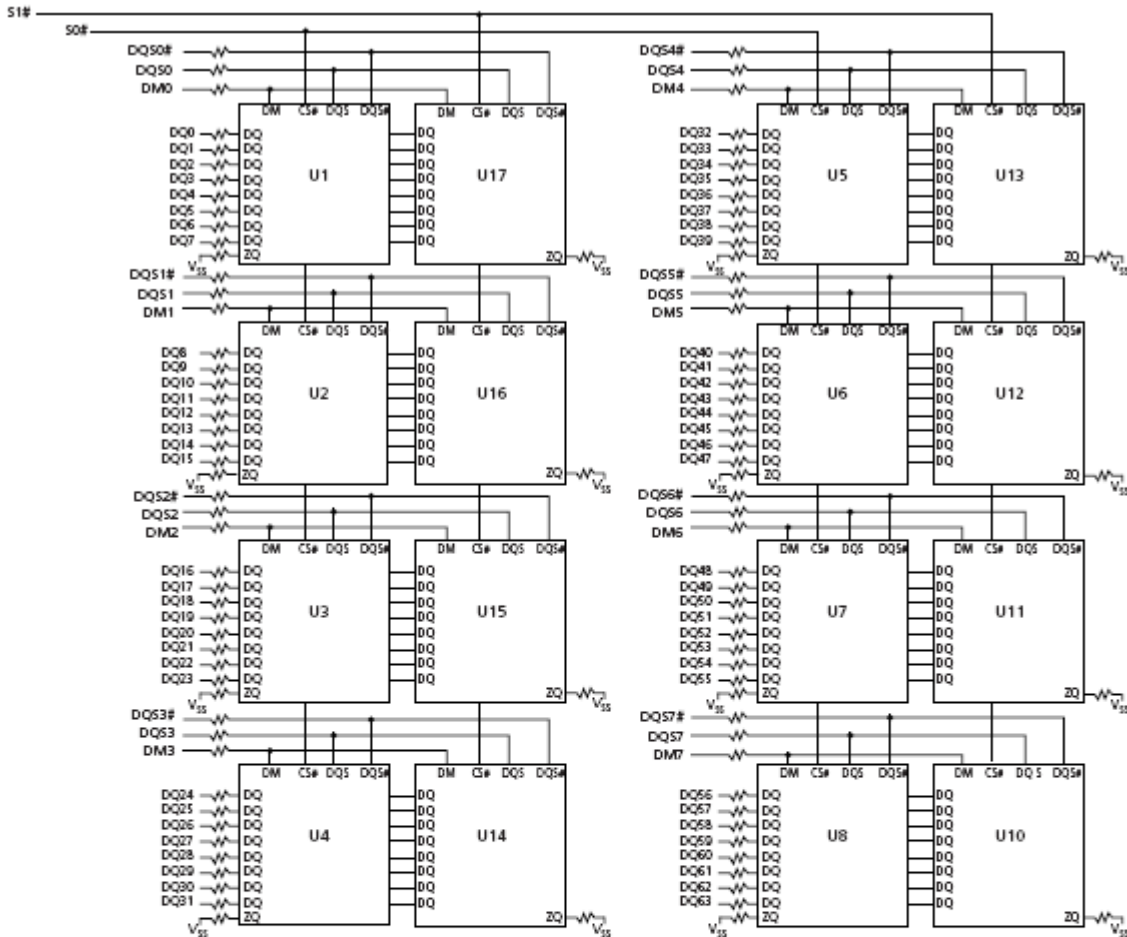

Note: 1. The ZQ ball on each DDR3 component is connected to an external 240Ω ±1% resistor that is tied to ground. Used for the calibration of the component's on-die termination and output driver.

**9.0 AC & DC Operating Conditions**

Recommended operating conditions (Voltage referenced to V<sub>SS</sub>=0V, TA=0 to 70°C)

Symbol	Parameter	Min	Typ	Max	Unit
V <sub>DD</sub>	Supply Voltage	1.425	1.5	1.575	V
V <sub>DDQ</sub>	Supply Voltage for Output	1.425	1.5	1.575	V
V <sub>REFDQ(DC)</sub>	I/O Reference Voltage (DQ)	0.49*V <sub>DDQ</sub>	0.50*V <sub>DDQ</sub>	0.51*V <sub>DDQ</sub>	V
V <sub>REFCA(DC)</sub>	I/O Reference Voltage (CMD/Add)	0.49*V <sub>DDQ</sub>	0.50*V <sub>DDQ</sub>	0.51*V <sub>DDQ</sub>	V
V <sub>TT</sub>	Termination Voltage	0.49*V <sub>DDQ</sub>	0.50*V <sub>DDQ</sub>	0.51*V <sub>DDQ</sub>	V

**10.0 Capacitance (Max.)**

Symbol	Parameter/Condition	Min	Max	Unit
CCK	Input capacitance, CK and $\overline{CK}$	-	11	pF
CI1	Input capacitance, CKE and $\overline{CS}$	-	12	pF
CI2	Input capacitance, Addr, $\overline{RAS}$ , $\overline{CAS}$ , $\overline{WE}$	-	12	pF
CIO	Input capacitance, DQ, DM, DQS, $\overline{DQS}$	-	10	pF

**11.1 AC Timing Parameters & Specifications**

(AC operating conditions unless otherwise noted)

Parameter	Symbol	DDR3-1600		Units
		min	max	
Minimum Clock Cycle Time (DLL off mode)	tCK(DLL_OFF)	8	-	ns
Average Clock Period	tCK(avg)	-		ps
Clock Period	tCK(abs)	tCK(avg) min +tJIT(per)min	tCK(avg) max +tJIT(per)max	ps
Average high pulse width	tCH(avg)	0.47	0.53	tCK(avg)
Average low pulse width	tCL(avg)	0.47	0.53	tCK(avg)
Clock Period Jitter	tJIT(per)	-70	70	ps
Clock Period Jitter during DLL locking period	tJIT(per, lck)	-60	60	ps
Cycle to Cycle Period Jitter	tJIT(cc)	140	-	ps
Cycle to Cycle Period Jitter during DLL locking period	tJIT(cc, lck)	120	-	ps
Cumulative error across 2 cycles	tERR(2per)	- 103	103	ps
Cumulative error across 3 cycles	tERR(3per)	- 122	122	ps
Cumulative error across 4 cycles	tERR(4per)	- 136	136	ps
Cumulative error across 5 cycles	tERR(5per)	- 147	147	ps
Cumulative error across 6 cycles	tERR(6per)	- 155	155	ps
Cumulative error across 7 cycles	tERR(7per)	- 163	163	ps
Cumulative error across 8 cycles	tERR(8per)	- 169	169	ps
Cumulative error across 9 cycles	tERR(9per)	- 175	175	ps
Cumulative error across 10 cycles	tERR(10per)	- 180	180	ps

**11.2 AC Timing Parameters & Specifications (con't)**

Parameter	Symbol	DDR3-1600		Units
		min	max	
Cumulative error across 11 cycles	tERR(11per)	- 184	184	ps
Cumulative error across 12 cycles	tERR(12per)	- 188	188	ps
Cumulative error across n = 13, 14 ... 49, 50 cycles	tERR(nper)	tERR(nper)min = (1 + 0.68ln(n))*tJIT(per)min tERR(nper)max = (1 = 0.68ln(n))*tJIT(per)max		ps
Absolute clock HIGH pulse width	tCH(abs)	0.43	-	tCK(avg)
Absolute clock Low pulse width	tCL(abs)	0.43	-	tCK(avg)
<b>Data Timing</b>				
DQS, /DQS to DQ skew, per group, per access	tDQSQ	-	100	ps
DQ output hold time from DQS, /DQS	tQH	0.38	-	tCK(avg)
DQ low-impedance time from CK, /CK	tLZ(DQ)	-450	225	ps
DQ high-impedance time from CK, /CK	tHZ(DQ)	-	225	ps
Data setup time to DQS, /DQS referenced to Vih(ac)/Vil(ac) levels	tDS(base) AC175	TBD	-	ps
	tDS(base) AC150	10	-	ps
Data hold time to DQS, /DQS referenced to Vih(ac)/Vil(ac) levels	tDH(base) DC100	45	-	ps
DQ and DM Input pulse width for each input	tDIPW	360	-	ps
<b>Data Strobe Timing</b>				
DQS, /DQS READ Preamble	tRPRE	0.9	-	tCK
DQS, /DQS differential READ Postamble	tRPST	0.3	-	tCK
DQS, /DQS output high time	tQSH	0.4	-	tCK(avg)
DQS, /DQS output low time	tQSL	0.4	-	tCK(avg)
DQS, /DQS WRITE Preamble	tWPRE	0.9	-	tCK
DQS, /DQS WRITE Postamble	tWPST	0.3	-	tCK
DQS, /DQS rising edge output access time from rising CK, /CK	tDQSCK	-225	225	ps
DQS, /DQS low-impedance time (Referenced from RL-1)	tLZ(DQS)	-450	225	ps
DQS, /DQS high-impedance time (Referenced from RL+BL/2)	tHZ(DQS)	-	225	ps
DQS, DQS differential input low pulse width	tDQSL	0.45	0.55	tCK
DQS, DQS differential input high pulse width	tDQSH	0.45	0.55	tCK
DQS, DQS rising edge to CK, /CK rising edge	tDQSS	-0.27	0.27	tCK(avg)
DQS, DQS falling edge setup time to CK, /CK rising edge	tDSS	0.18	-	tCK(avg)
DQS, DQS falling edge hold time to CK, /CK rising edge	tDSH	0.18	-	tCK(avg)
DLL locking time	tDLLK	512	-	nCK
internal READ Command to PRECHARGE Command delay	tRTP	max (4tCK, 7.5ns)	-	
Delay from start of internal write transaction to internal read command	tWTR	max (4tCK, 7.5ns)	-	
WRITE recovery time	tWR	15	-	ns
Mode Register Set command cycle time	tMRD	4	-	nCK
Mode Register Set command update delay	tMOD	max (12tCK, 15ns)	-	
CAS# to CAS# command delay	tCCD	4	-	nCK
Auto precharge write recovery + precharge time	tDAL(min)	WR + roundup (tRP / tCK(AVG))		nCK

**11.3 AC Timing Parameters & Specifications (con't)**

Parameter	Symbol	DDR3-1600		Units
		min	max	
Multi-Purpose Register Recovery Time	tMPRR	1	-	nCK
ACTIVE to PRECHARGE command period	tRAS	36	70,000	ns
ACTIVE to ACTIVE command period for 1KB page size	tRRD	max (4tCK,6ns)	-	
ACTIVE to ACTIVE command period for 2KB page size	tRRD	max (4tCK,7.5ns)	-	
Four activate window for 1KB page size	tFAW	30	-	ns
Four activate window for 2KB page size	tFAW	40	-	ns
Command and Address setup time to CK, /CK referenced to Vih(ac) / Vil(ac) levels	tIS(base) AC175	45	-	ps
	tIS(base) AC150	45+125	-	ps
Command and Address hold time from CK, /CK referenced to Vih(ac) / Vil(ac) levels	tIH(base) DC100	120	-	ps
Control & Address Input pulse width for each input	tIPW	560	-	ps
<b>Calibration Timing</b>				
Power-up and RESET calibration time	tZQinitl	512	-	tCK
Normal operation Full calibration time	tZQoper	256	-	tCK
Normal operation short calibration time	tZQCS	64	-	tCK
<b>Reset Timing</b>				
Exit Reset from CKE HIGH to a valid command	tXPR	max(5tCK, tRFC+ 10ns)	-	
<b>Self Refresh Timing</b>				
Exit Self Refresh to commands not requiring a locked DLL	tXS	max(5tCK, tRFC+ 10ns)	-	
Exit Self Refresh to commands requiring a locked DLL	tXSDLL	tDLLK(min)	-	nCK
Minimum CKE low width for Self refresh entry to exit timing	tCKESR	tCKE(min) + 1tCK	-	
Valid Clock Requirement after Self Refresh Entry (SRE)	tCKSRE	max(5tCK, 10ns)	-	
Valid Clock Requirement before Self Refresh Exit (SRX)	tCKSRX	max(5tCK, 10ns)	-	
<b>Power Down Timing</b>				
Exit Power Down with DLL on to any valid command; Exit Precharge Power Down with DLL frozen to commands not requiring a locked DLL	tXP	max (3tCK,6ns)	-	
Exit Precharge Power Down with DLL frozen to commands requiring a locked DLL	tXPDLL	max(10tCK, 24ns)	-	
CKE minimum pulse width	tCKE	max(3tCK, 5 ns)	-	
Command pass disable delay	tCPDED	1	-	nCK
Power Down Entry to Exit Timing	tPD	tCKE(min)	9*tREFI	tCK
Timing of ACT command to Power Down entry	tACTPDEN	1	-	nCK
Timing of PRE command to Power Down entry	tPRPDEN	1	-	nCK
Timing of RD/RDA command to Power Down entry	tRDPDEN	RL + 4 + 1	-	
Timing of WR command to Power Down entry (BL8OTF, BL8MRS, BL4OTF)	tWRPDEN	WL + 4 + (tWR/tCK)	-	nCK
Timing of WRA command to Power Down entry (BL8OTF, BL8MRS, BL4OTF)	tWRAPDEN	WL + 4 + WR + 1	-	nCK
Timing of WR command to Power Down entry (BL4MRS)	tWRPDEN	WL + 2 + (tWR/ tCK(avg))	-	nCK

**11.4 AC Timing Parameters & Specifications (con't)**

Parameter	Symbol	DDR3-1600		Units
		min	max	
Timing of WRA command to Power Down entry (BL4MRS)	tWRAPDEN	WL +2 +WR +1	-	nCK
Timing of REF command to Power Down entry	tREFPDEN	1	-	
Timing of MRS command to Power Down entry	tMRSPDEN	tMOD(min)	-	
<b>ODT Timing</b>				
ODT high time without write command or with write command and BC4	ODTH4	4	-	nCK
ODT high time with Write command and BL8	ODTH8	6	-	nCK
Asynchronous RTT turn-on delay (Power-Down with DLL frozen)	tAONPD	2	8.5	ns
Asynchronous RTT turn-off delay (Power-Down with DLL frozen)	tAOFPD	2	8.5	ns
ODT turn-on	tAON	-225	225	ps
RTT_NOM and RTT_WR turn-off time from ODTL off reference	tAOF	0.3	0.7	tCK(avg)
RTT dynamic change skew	tADC	0.3	0.7	tCK(avg)
<b>Write Leveling Timing</b>				
First DQS pulse rising edge after tDQSS margining mode is programmed	tWLMRD	40	-	tCK
DQS/DQS delay after tDQS margining mode is programmed	tWLDQSEN	25	-	tCK
Setup time for tDQSS latch	tWLS	165	-	ps
Hold time of tDQSS latch	tWLH	165	-	ps
Write leveling output delay	tWLO	0	7.5	ns
Write leveling output error	tWLOE	0	2	ns

**11.0 Physical Dimensions: (512Mbx8 Based, 1Gx64, 2 ranks)**

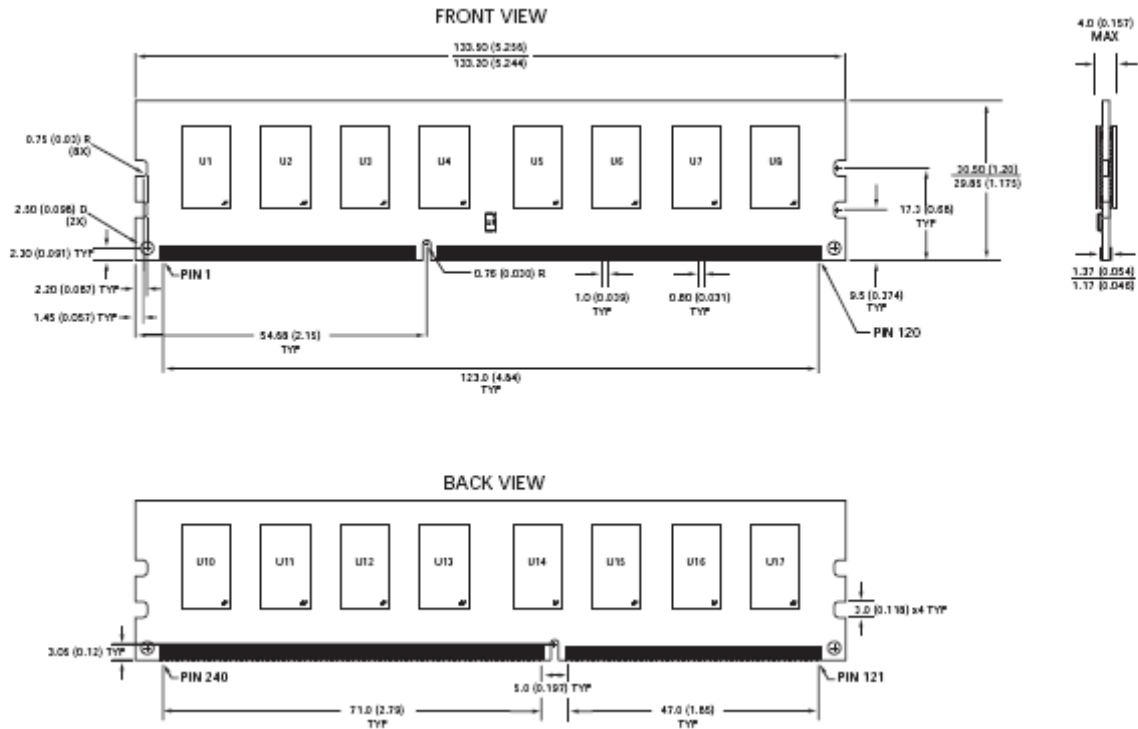

Tolerances :± 0.005(.13) unless otherwise specified