

# **DDR3 VLP-Unbuffered DIMM Module**

**2GB based on 1Gbit component**

**TFBGA with Pb-Free**



**Revision 1.0 (MAY. 2007)**  
-Initial Release

**1.0 Feature**

- JEDEC standard VDD = VDDQ = 1.5V +/- 0.075V Power Supply
- 1.5V centered-terminated push-pull I/O
- Programmable CAS latencies (5,6,7,8,9,10), Burst Length (4 & 8) and Burst Type
- Auto Refresh (CRB) and Self Refresh
- Bi-directional Differential Data Strobe
- Off Chip Driver (OCD) impedance adjustment
- On-Die termination using ODT pin
- 8 independent internal bank
- Average Refresh Period 7.8us at lower than a TCASE 85°C, 3.9us at 85°C < TCASE < 95 °C - support High Temperature Self-Refresh rate enable feature
- Serial presence detect with EEPROM
- VLP-UDIMM Dimension (Nominal) 18.75 mm high, 133.35 mm wide
- Based on JEDEC standard reference Raw Cards Lay out.
- RoHS compliant
- Gold plated contacts

**2.0 Ordering Information**

Part number	Density	Module Organization	Component composition	Component PKG	Module Rank	Description
W1333LB2Gx	2GB	256Mx64	128Mx8*16	TFBGA	2	2GB 2Rx8 PC3-10600U

Note: Last Character x of the Part Number stand for DRAM vendor  
S=Samsung; M=Micron; Q=Qimonda; H=Hynix; E=Elpida

**3.0 Key Timing Parameters**

	DDR3-1333	DD3-1066	Unit
CL-tRCD-tRP	9-9-9	7-7-7	tCK
CAS Latency	9	7	tCK
tCK(min)	1.5	1.875	ns
tRCD(min)	13.5	13.125	ns
tRP(min)	13.5	13.125	ns
tRAS(min)	36	37.5	ns
tRC(min)	49.5	50.625	ns

**4.0 Absolute Maximum DC Rating**

Symbol	Parameter	Rating	Units
V <sub>in</sub> , V <sub>out</sub>	Voltage on any pin relative to V <sub>SS</sub>	-0.4 ~ 1.975	V
V <sub>DD</sub>	Voltage on V <sub>DD</sub> & V <sub>DDQ</sub> supply relative to V <sub>SS</sub>	-0.4 ~ 1.975	V
V <sub>DDQ</sub>	Short circuit current	-0.4 ~ 1.975	V
V <sub>DDL</sub>	Power dissipation	-0.4 ~ 1.975	V
T <sub>STG</sub>	Storage Temperature	-55 ~ + 100	°C

**5.0 DIMM Pin Configurations (Front side/Back side)**

Pin	Front	Pin	Back	Pin	Front	Pin	Back	Pin	Front	Pin	Back
1	V <sub>REF</sub> DQ	121	V <sub>SS</sub>	41	V <sub>SS</sub>	161	DM8/DQS17_P	81	DQ32	201	DQ37
2	V <sub>SS</sub>	122	DQ4	42	NC	162	DQS17_N	82	DQ33	202	V <sub>SS</sub>
3	DQ0	123	DQ5	43	NC	163	V <sub>SS</sub>	83	V <sub>SS</sub>	203	DM4/DQS13_P
4	DQ1	124	V <sub>SS</sub>	44	V <sub>SS</sub>	164	NC	84	DQS4_N	204	DQS13_N
5	V <sub>SS</sub>	125	DM0/DQS9_P	45	NC	165	NC	85	DQS4_P	205	V <sub>SS</sub>
6	DQS0_N	126	NC/DQS9_N	46	NC	166	V <sub>SS</sub>	86	V <sub>SS</sub>	206	DQ38
7	DQS0_P	127	V <sub>SS</sub>	47	V <sub>SS</sub>	167	NC/TEST	87	DQ34	207	DQ39
8	V <sub>SS</sub>	128	DQ6	48	NC	168	RESET_N	88	DQ35	208	V <sub>SS</sub>
9	DQ2	129	DQ7	KEY				89	V <sub>SS</sub>	209	DQ44
10	DQ3	130	V <sub>SS</sub>	49	NC	169	CKE1	90	DQ40	210	DQ45
11	V <sub>SS</sub>	131	DQ12	50	CKE0	170	VDD	91	DQ41	211	V <sub>SS</sub>
12	DQ8	132	DQ13	51	VDD	171	A15	92	V <sub>SS</sub>	212	DM5/DQS14_P
13	DQ9	133	V <sub>SS</sub>	52	BA2	172	A14	93	DQS5_N	213	DQS14_N
14	V <sub>SS</sub>	134	DM1/DQS10_P	53	NC/Err-Out	173	VDD	94	DQS5_P	214	V <sub>SS</sub>
15	DQS1_N	135	DQS10_N	54	VDD	174	A12	95	V <sub>SS</sub>	215	DQ46
16	DQS2_P	136	V <sub>SS</sub>	55	A11	175	A9	96	DQ42	216	DQ47
17	V <sub>SS</sub>	137	DQ14	56	A7	176	VDD	97	DQ43	217	V <sub>SS</sub>
18	DQ10	138	DQ15	57	VDD	177	A8	98	V <sub>SS</sub>	218	DQ52
19	DQ11	139	V <sub>SS</sub>	58	A5	178	A6	99	DQ48	219	DQ53
20	V <sub>SS</sub>	140	DQ20	59	A4	179	VDD	100	DQ49	220	V <sub>SS</sub>
21	DQ16	141	DQ21	60	VDD	180	A3	101	V <sub>SS</sub>	221	DM6_DQS15_P
22	DQ17	142	V <sub>SS</sub>	61	A2	181	A1	102	DQS6_N	222	DQS15_N
23	V <sub>SS</sub>	143	DQS11_P	62	VDD	182	VDD	103	DQS6_P	223	V <sub>SS</sub>
24	DQS2_N	144	DQS11_N	63	CK1_P/NC	183	VDD	104	V <sub>SS</sub>	224	DQ54
25	DQS2_P	145	V <sub>SS</sub>	64	CK1_N/NC	184	CK0_P	105	DQ50	225	DQ55
26	V <sub>SS</sub>	146	DQ22	65	VDD	185	CK0_N	106	DQ51	226	V <sub>SS</sub>
27	DQ18	147	DQ23	66	VDD	186	VDD	107	V <sub>SS</sub>	227	DQ60
28	DQ19	148	V <sub>SS</sub>	67	V <sub>REF</sub> CA	187	NC/EVENT	108	DQ56	228	DQ61
29	V <sub>SS</sub>	149	DQ28	68	NC, Par_In	188	A0	109	DQ57	229	V <sub>SS</sub>
30	DQ24	150	DQ29	69	VDD	189	VDD	110	V <sub>SS</sub>	230	DM7/DQS16_P
31	DQ25	151	V <sub>SS</sub>	70	A10/AP	190	BA1	111	DQS7_N	231	DQS16_N
32	V <sub>SS</sub>	152	DM3/DQS12_P	71	BA0	191	VDD	112	DQS7_P	232	V <sub>SS</sub>
33	DQ3_N	153	DQS12_N	72	VDD	192	RAS_N	113	V <sub>SS</sub>	233	DQ62
34	DQ3_P	154	V <sub>SS</sub>	73	WE	193	S0_N	114	DQ58	234	DQ63
35	V <sub>SS</sub>	155	DQ30	74	CAS	194	VDD	115	DQ59	235	V <sub>SS</sub>
36	DQ26	156	DQ31	75	VDD	195	ODT0	116	V <sub>SS</sub>	236	V <sub>DD</sub> SPD
37	DQ27	157	V <sub>SS</sub>	76	S1	196	A13	117	SA0	237	SA1
38	V <sub>SS</sub>	158	NC	77	ODT1	197	VDD	118	SCL	238	SDA
39	NC	159	NC	78	VDD	198	NC	119	SA2	239	V <sub>SS</sub>
40	NC	160	V <sub>SS</sub>	79	S2/NC	199	V <sub>SS</sub>	120	V <sub>TT</sub>	240	V <sub>TT</sub>
				80	V <sub>SS</sub>	200	DQ36				

NC = No Connect, RFU = Reserved for Future Use

1. Par\_in and Err\_out pins are intended for register control functions.

**6.0 DIMM Pin Description**

Pin Name	Function	Pin Name	Function
A0 ~ A15	Address input (Multiplexed)	ODT0~ODT1	On Die Termination
A10/AP	Address Input/Auto pre-charge	CB0~CB7	ECC Data check bits Input/Output
BA0 ~ BA2	Bank Select	DQ0~DQ63	Data Input/Output
$\overline{CK0} \sim \overline{CK2}$ , CK0~CK2	Clock input	$\overline{DQS0} \sim \overline{DQS8}$	Data strobes, negative line
CKE0, CKE1	Clock enable input	DM (0~8),	Data Masks/Data strobes (Read)
$\overline{S0}$ , $\overline{S1}$	Chip select input	DQS0~DQS8	Data Strobes
$\overline{RAS}$	Row address strobe	RFU	Reserved for future used
$\overline{CAS}$	Column address strobe	V <sub>TT</sub>	SDRAM I/O termination power supply
$\overline{WE}$	Write Enable	TEST	Memory bus test tool
SCL	SPD Clock Input	V <sub>DD</sub>	Core Power
SDA	SPD Data Input/Output	V <sub>DDQ</sub>	I/O Power
SA0~SA2	SPD Address	V <sub>SS</sub>	Ground
Par_In	Parity bit for address & Control bus	V <sub>REFDQ</sub>	SDRAM Input/Output Reference Supply
Err_Out	Parity error found in the Address and Control bus	V <sub>DDSPD</sub>	Serial EEPROM Power Supply
$\overline{RESET}$	Register and PLL control pin	V <sub>REFCA</sub>	Command Address Reference Supply

**7.0 Address Configuration**

Organization	Row Address	Column Address	Bank Address	Auto Pre-charge
128Mx8(1Gb) base	A0-A13	A0-A9	BA0-BA2	A10/AP

**240-Pin VLP-Unbuffered DIMM**

**DDR3 SDRAM**

**8.0 Functional Block Diagram: 2GB, 256Mx64 Module (Populated as 2 ranks of x8)**

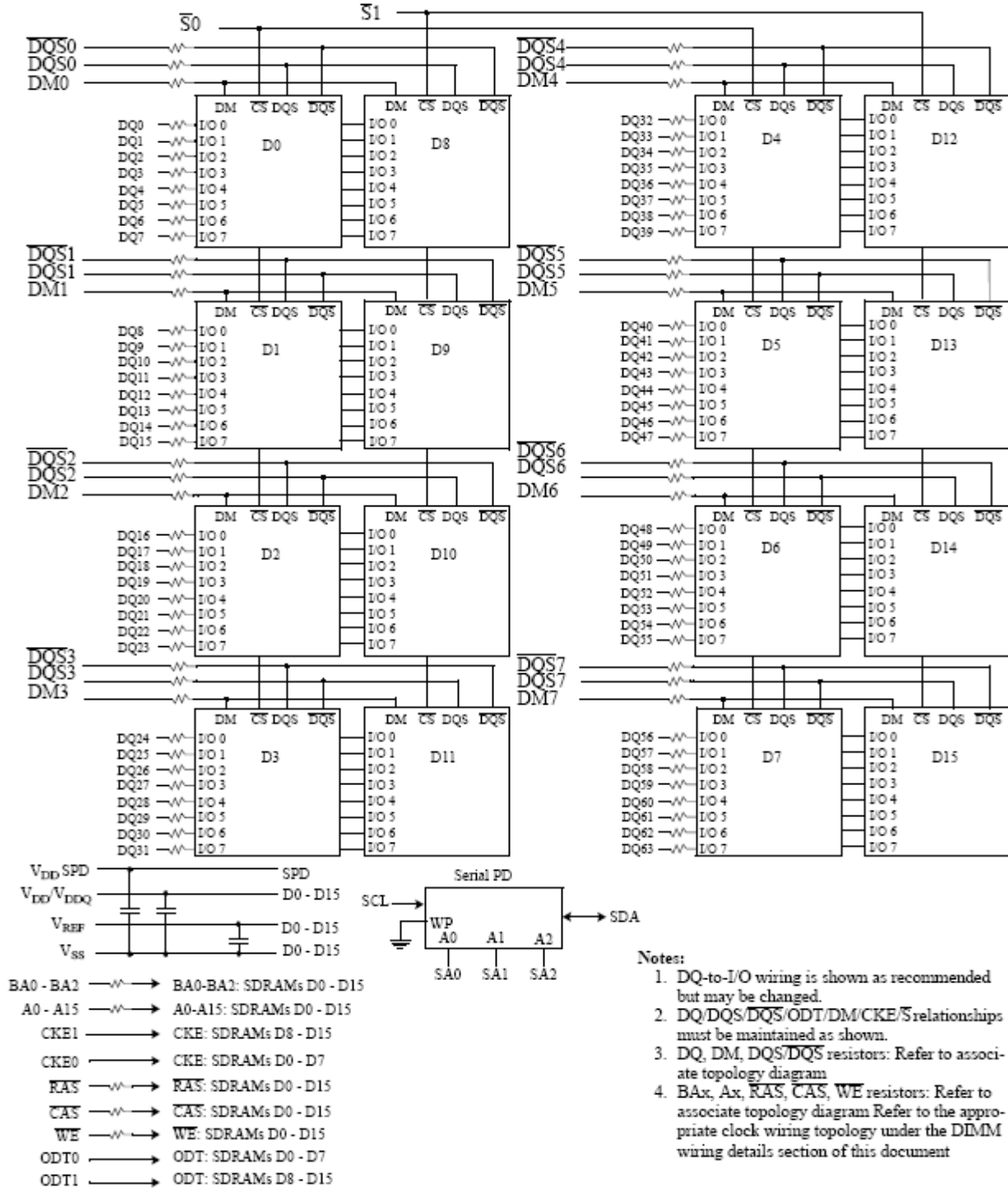

**9.0 AC & DC Operating Conditions**

Recommended operating conditions (Voltage referenced to V<sub>SS</sub>=0V, TA=0 to 70°C)

Symbol	Parameter	Min	Typ	Max	Unit
V <sub>DD</sub>	Supply Voltage	1.425	1.5	1.575	V
V <sub>DDQ</sub>	Supply Voltage for Output	1.425	1.5	1.575	V
V <sub>REFDQ(DC)</sub>	I/O Reference Voltage (DQ)	0.49*V <sub>DDQ</sub>	0.50*V <sub>DDQ</sub>	0.51*V <sub>DDQ</sub>	V
V <sub>REFCA(DC)</sub>	I/O Reference Voltage (CMD/Add)	0.49*V <sub>DDQ</sub>	0.50*V <sub>DDQ</sub>	0.51*V <sub>DDQ</sub>	V
V <sub>TT</sub>	Termination Voltage	0.49*V <sub>DDQ</sub>	0.50*V <sub>DDQ</sub>	0.51*V <sub>DDQ</sub>	V

**10.0 Capacitance (Max.)**

Symbol	Parameter/Condition	Min	Max	Unit
CCK	Input capacitance, CK and $\overline{CK}$	-	11	pF
CII	Input capacitance, CKE and $\overline{CS}$	-	12	pF
CI2	Input capacitance, Addr, RAS, $\overline{CAS}$ , WE	-	12	pF
CIO	Input capacitance, DQ, DM, DQS, $\overline{DQS}$	-	10	pF

**11.1 AC Timing Parameters & Specifications**

(AC operating conditions unless otherwise noted)

Parameter	Symbol	DDR3-1066		DDR3-1333		Units	Notes
		min	max	min	max		
Minimum Clock Cycle Time (DLL off mode)	tCK(DLL_OFF)	8	-	8	-	ns	6
Average Clock Period	tCK(avg)	See Speed Bins Table				ps	
Clock Period	tCK(abs)	tCK(avg) min +tJIT (per)min	tCK(avg) max +tJIT (per)max	tCK(avg) min +tJIT (per)min	tCK(avg) max +tJIT (per)max	ps	
Average high pulse width	tCH(avg)	0.47	0.53	0.47	0.53	tCK(avg)	
Average low pulse width	tCL(avg)	0.47	0.53	0.47	0.53	tCK(avg)	
Clock Period Jitter	tJIT(per)	-90	90	-80	80	ps	
Clock Period Jitter during DLL locking period	tJIT(per, lck)	-90	90	-80	80	ps	
Cycle to Cycle Period Jitter	tJIT(cc)	180		160		ps	
Cycle to Cycle Period Jitter during DLL locking period	tJIT(cc, lck)	160		140		ps	
Cumulative error across 2 cycles	tERR(2per)	- 132	132	- 118	118	ps	
Cumulative error across 3 cycles	tERR(3per)	- 157	157	- 140	140	ps	
Cumulative error across 4 cycles	tERR(4per)	- 175	175	- 155	155	ps	
Cumulative error across 5 cycles	tERR(5per)	- 188	-188	- 168	168	ps	
Cumulative error across 6 cycles	tERR(6per)	- 200	200	- 177	177	ps	
Cumulative error across 7 cycles	tERR(7per)	- 209	209	- 186	186	ps	
Cumulative error across 8 cycles	tERR(8per)	- 217	217	- 193	193	ps	
Cumulative error across 9 cycles	tERR(9per)	- 224	224	- 200	200	ps	
Cumulative error across 10 cycles	tERR(10per)	- 231	231	- 205	205	ps	

**11.2 AC Timing Parameters & Specifications (con't)**

Parameter	Symbol	DDR3-1066		DDR3-1333		Units	Notes
		min	max	min	max		
Cumulative error across 11 cycles	tERR(11per)	- 237	237	- 210	210	ps	
Cumulative error across 12 cycles	tERR(12per)	- 242	242	- 215	215	ps	
Cumulative error across n = 13, 14 ... 49, 50 cycles	tERR(nper)	$tERR(nper)_{min} = (1 + 0.68\ln(n)) * tJIT(per)_{min}$ $tERR(nper)_{max} = (1 + 0.68\ln(n)) * tJIT(per)_{max}$				ps	24
Absolute clock HIGH pulse width	tCH(abs)	0.43	-	0.43	-	tCK(avg)	25
Absolute clock Low pulse width	tCL(abs)	0.43	-	0.43	-	tCK(avg)	26
<b>Data Timing</b>							
DQS, /DQS to DQ skew, per group, per access	tDQSQ	-	150	-	125	ps	13
DQ output hold time from DQS, /DQS	tQH	0.38	-	0.38	-	tCK(avg)	13,g
DQ low-impedance time from CK, /CK	tLZ(DQ)	-600	300	-500	250	ps	13,14,f
DQ high-impedance time from CK, /CK	tHZ(DQ)	-	300	-	250	ps	13,14,f
Data setup time to DQS, /DQS referenced to Vih(ac)/Vil(ac) levels	tDS(base)	25	-	TBD	-	ps	d,17
Data hold time to DQS, /DQS referenced to Vih(ac)/Vil(ac) levels	tDH(base)	100	-	TBD	-	ps	d,17
DQ and DM Input pulse width for each input	tDIPW	490	-	400	-	ps	28
<b>Data Strobe Timing</b>							
DQS, /DQS READ Preamble	tRPRE	0.9	Note 19	0.9	Note 19	tCK	13,19,g
DQS, /DQS differential READ Postamble	tRPST	0.3	Note 11	0.3	Note 11	tCK	11,13,g
DQS, /DQS output high time	tQSH	0.38	-	0.4	-	tCK(avg)	
DQS, /DQS output low time	tQSL	0.38	-	0.4	-	tCK(avg)	
DQS, /DQS WRITE Preamble	tWPRE	0.9	-	0.9	-	tCK	
DQS, /DQS WRITE Postamble	tWPST	0.3	-	0.3	-	tCK	
DQS, /DQS rising edge output access time from rising CK, /CK	tDQSCK	-300	300	-255	255	ps	13,f
DQS, /DQS low-impedance time (Referenced from RL-1)	tLZ(DQS)	-600	300	-500	250	ps	13,14,f
DQS, /DQS high-impedance time (Referenced from RL+BL/2)	tHZ(DQS)	300	-	250	-	ps	12,13,14
DQS, DQS differential input low pulse width	tDQSL	0.45	0.55	0.45	0.55	tCK	28,30
DQS, DQS differential input high pulse width	tDQSH	0.45	0.55	0.45	0.55	tCK	29,30
DQS, DQS rising edge to CK, CK rising edge	tDQSS	-0.25	0.25	-0.25	0.25	tCK(avg)	C
DQS, DQS falling edge setup time to CK, CK rising edge	tDSS	0.2	-	0.2	-	tCK(avg)	C,31
DQS, DQS falling edge hold time to CK, CK rising edge	tDSH	0.2	-	0.2	-	tCK(avg)	C,31
DLL locking time	tDLLK	512	-	512	-	nCK	
internal READ Command to PRECHARGE Command delay	tRTP	max (4tCK, 7.5ns)	-	max (4tCK, 7.5ns)	-		e
Delay from start of internal write transaction to internal read command	tWTR	max (4tCK, 7.5ns)	-	max (4tCK, 7.5ns)	-		e,18
WRITE recovery time	tWR	15	-	15	-	ns	e
Mode Register Set command cycle time	tMRD	4	-	4	-	nCK	
Mode Register Set command update delay	tMOD	max (12tCK, 15ns)	-	max (12tCK, 15ns)	-		
CAS# to CAS# command delay	tCCD	4	-	4	-	nCK	
Auto precharge write recovery + precharge time	tDAL(min)	WR + roundup (tRP / tCK(AVG))				nCK	

**11.3 AC Timing Parameters & Specifications (con't)**

Parameter	Symbol	DDR3-1066		DDR3-1333		Units	Notes
		min	max	min	max		
Multi-Purpose Register Recovery Time	tMPRR	1	-	1	-	nCK	
ACTIVE to PRECHARGE command period	tRAS	37.5	70,000	36	70,000	ns	e
ACTIVE to ACTIVE command period for 1KB page size	tRRD	max (4tCK,7.5ns)	-	max (4tCK,6ns)	-		e
ACTIVE to ACTIVE command period for 2KB page size	tRRD	max (4tCK,10ns)	-	max (4tCK,7.5ns)	-		e
Four activate window for 1KB page size	tFAW	37.5	-	30	-	ns	e
Four activate window for 2KB page size	tFAW	50	-	45	-	ns	e
Command and Address setup time to CK, CK referenced to Vih(ac) / Vil(ac) levels	tIS(base)	125	-	65	-	ps	b,16
Command and Address hold time from CK, CK referenced to Vih(ac) / Vil(ac) levels	tIH(base)	200	-	140	-	ps	b,16
Command and Address setup time to CK, CK referenced to Vih(ac) / Vil(ac) levels	tIS(base) AC150	-	-	65+125	-	ps	b,16,27
Control & Address Input pulse width for each input	tIPW	780	-	620	-	ps	28
<b>Calibration Timing</b>							
Power-up and RESET calibration time	tZQinitl	512	-	512	-	tCK	
Normal operation Full calibration time	tZQoper	25	-	256	-	tCK	
Normal operation short calibration time	tZQCS	64	-	64	-	tCK	23
<b>Reset Timing</b>							
Exit Reset from CKE HIGH to a valid command	tXPR	max(5tCK, tRFC+ 10ns)	-	max(5tCK, tRFC+ 10ns)	-		
<b>Self Refresh Timing</b>							
Exit Self Refresh to commands not requiring a locked DLL	tXS	max(5tCK,tRF C+ 10ns)	-	max(5tCK,tRF C+ 10ns)	-		
Exit Self Refresh to commands requiring a locked DLL	tXSDLL	tDLLK(min)	-	tDLLK(min)	-	nCK	
Minimum CKE low width for Self refresh entry to exit timing	tCKESR	tCKE(min) + 1tCK	-	tCKE(min) + 1tCK	-		
Valid Clock Requirement after Self Refresh Entry (SRE)	tCKSRE	max(5tCK, 10ns)	-	max(5tCK, 10ns)	-		
Valid Clock Requirement before Self Refresh Exit (SRX)	tCKSRX	max(5tCK, 10ns)	-	max(5tCK, 10ns)	-		
<b>Power Down Timing</b>							
Exit Power Down with DLL on to any valid command; Exit Precharge Power Down with DLL frozen to commands not requiring a locked DLL	tXP	max (3tCK,7.5ns)	-	max (3tCK,6ns)	-		
Exit Precharge Power Down with DLL frozen to commands requiring a locked DLL	tXPDLL	max(10tCK, 24ns)	-	max(10tCK, 24ns)	-		2
CKE minimum pulse width	tCKE	max(3tCK, 5.625ns)	-	max(3tCK, 5.625ns)	-		
Command pass disable delay	tCPDED	1	-	1	-	nCK	
Power Down Entry to Exit Timing	tPD	tCKE(min)	9*tREFI	tCKE(min)	9*tREFI	tCK	15
Timing of ACT command to Power Down entry	tACTPDEN	1	-	1	-	nCK	20
Timing of PRE command to Power Down entry	tPRPDEN	1	-	1	-	nCK	20
Timing of RD/RDA command to Power Down entry	tRDPDEN	RL + 4 + 1	-	RL + 4 + 1	-		
Timing of WR command to Power Down entry (BL8OTF, BL8MRS, BL4OTF)	tWRPDEN	WL + 4 +(tWR/tCK)	-	WL + 4 +(tWR/tCK)	-	nCK	9
Timing of WRA command to Power Down entry (BL8OTF, BL8MRS, BL4OTF)	tWRAPDEN	WL + 4 +WR+1	-	WL + 4 +WR+1	-	nCK	10
Timing of WR command to Power Down entry (BL4MRS)	tWRPDEN	WL + 2 +(tWR/ tCK(avg))	-	WL + 2 +(tWR/ tCK(avg))	-	nCK	9

**11.4 AC Timing Parameters & Specifications (con't)**

Parameter	Symbol	DDR3-1066		DDR3-1333		Units	Notes
		min	max	min	max		
Timing of WRA command to Power Down entry (BL4MRS)	tWRAPDEN	WL +2 +WR +1	-	WL +2 +WR +1	-	nCK	10
Timing of REF command to Power Down entry	tREFPDEN	1	-	1	-		20,21
Timing of MRS command to Power Down entry	tMRSPDEN	tMOD(min)	-	tMOD(min)	-		
<b>ODT Timing</b>							
ODT high time without write command or with write command and BC4	ODTH4	4	-	4	-	nCK	
ODT high time with Write command and BL8	ODTH8	6	-	6	-	nCK	
Asynchronous RTT turn-on delay (Power-Down with DLL frozen)	tAONPD	1	9	1	9	ns	
Asynchronous RTT turn-off delay (Power-Down with DLL frozen)	tAOFPD	1	9	1	9	ns	
ODT turn-on	tAON	-300	300	-250	250	ps	7,f
RTT_NOM and RTT_WR turn-off time from ODTL off reference	tAOF	0.3	0.7	0.3	0.7	tCK(avg)	8,f
RTT dynamic change skew	tADC	0.3	0.7	0.3	0.7	tCK(avg)	f
<b>Write Leveling Timing</b>							
First DQS pulse rising edge after tDQSS margining mode is programmed	tWLMRD	40	-	40	-	tCK	3
DQS/DQS delay after tDQS margining mode is programmed	tWLDQSEN	25	-	25	-	tCK	3
Setup time for tDQSS latch	tWLS	245	-	195	-	ps	
Hold time of tDQSS latch	tWLH	245	-	195	-	ps	
Write leveling output delay	tWLO	0	9	0	9	ns	
Write leveling output error	tWLOE	0	2	0	2	ns	

**12.0 Physical Dimensions: (128Mbx8 Based, 256Mx64, 2 ranks)**

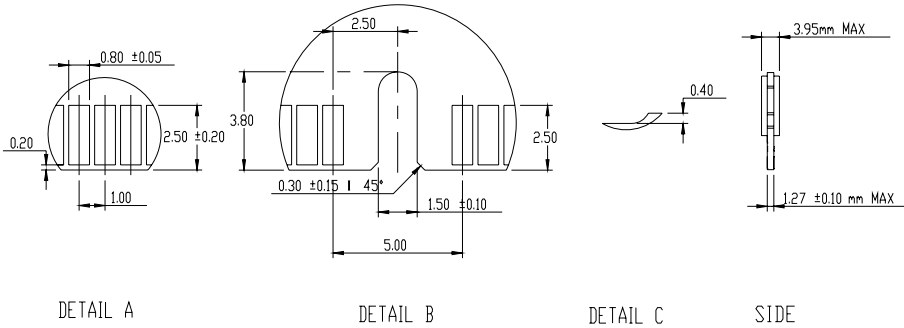
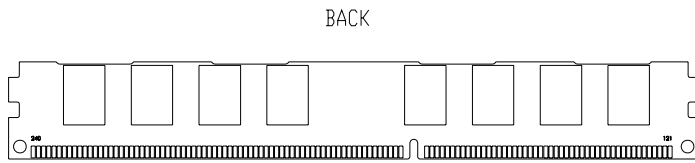
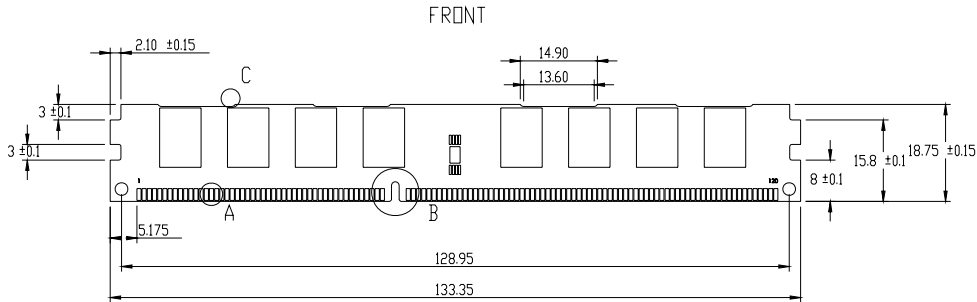

TOLERANCES: ± 0.005(.13) UNLESS OTHERWISE SPECIFIED

Tolerances :± 0.005(.13) unless otherwise specified