

6753 Low Pressure Airswitches



Technology Ltd

- Sensitive versatile switch, ideal for long tube lengths
- Ideal for switching low power circuits
- Temperature compensated versions available
- Easily adjustable settings



Outline dimensions

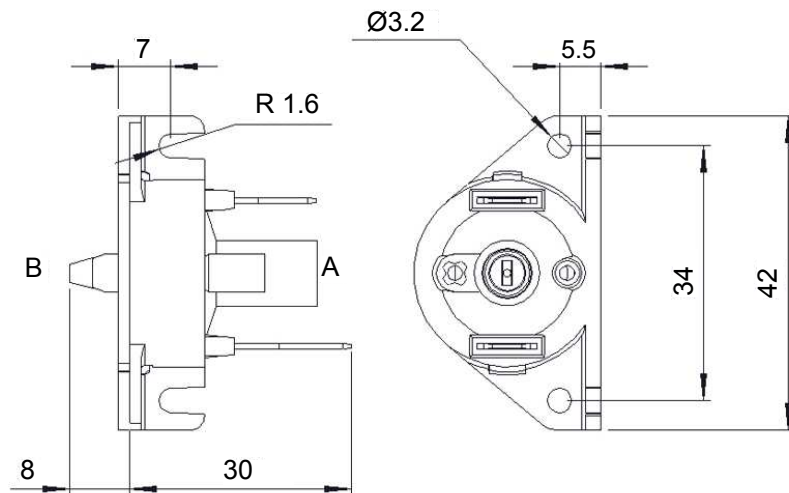

Ordering and options

Stock models: 6753-ACAA-A000

6753 - [] [] [] [] - [] [] []

Model

Contact configuration

- A SPST N/O
- B SPST N/C

Temperature compensation adjuster

- A A side only
- B B side only
- C Both sides
- E No option chosen

Temperature compensation setting

- A 100 - 300 cc/min factory setting (at 345 mbar flow)
- J No option chosen

Pressure setting (mbar)

- | | |
|----------------|----------------|
| A 5.6 +/- 22% | F 20.0 +/- 10% |
| B 5.0 +/- 25% | G 25.0 +/- 10% |
| C 7.5 +/- 16% | H 30.0 +/- 10% |
| D 10.0 +/- 12% | J 35.0 +/- 10% |

Packaging options

- A Vacuum form tray (100 off volumes - ideal for OEM applications)
- B Poly bag



General specifications

Standards/approvals	UL 508 specific models only	Pressure range	n/a
Degree of protection	n/a	Operating temperature range	-5°C to +40°C
Connection method	Via back entry spout, Ø4 mm	Body material	Thermoplastic
Electrical rating	0.5A 250V AC	Weight	0.01 kg
Contact configuration	SPST, N/O or N/C	Additional information	

6753 - Range options and technical data

Body withstand pressure	mbar	1,000	Electrical data	
Pressure connection		Ø4 mm spout Pressure or vacuum spout side varies according to contact configuration	Contact configuration	SPST N/O or N/C
Connecting tube reference		2311-08 or 2311-01 to suit Ø4mm	Contact plating	Gold or Silver
Diaphragm		Neoprene	Contact rating	Max. 0.5A 250 V AC
Mechanical life		1 x 10 ⁶ cycles	Dry switching current	Min. 5 mA 4 VDC
			Contact resistance	Ω 0.05

The 6753 range of switches provide a high specification in a small, versatile body shell. Great care has been taken in the switch unit design keeping the moving mass and therefore inertia to a minimum. This means that it can operate at a high cycle rate with low pressure or vacuum.

When measuring pressure pulses such as on component counting applications, the switch will operate very rapidly due to the low inertia of the moving parts and the low swept volume.

For good repeatable switching, the contacts are gold plated on solid silver. The operating pressure will have a direct effect on the contact pressure; therefore at very low pressures the maximum contact rating will not be achieved.

For a normally open switch the contacts can be closed either by applying pressure at port B or vacuum at port A.

For a normally closed switch, the contacts can be opened either by applying pressure at port A or vacuum at port B.

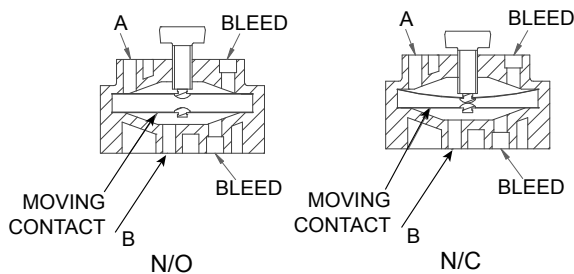

Where temperature compensation is required, consider carefully which side of the moving contact the bleed should be fitted. This will vary dependant on pressure or vacuum operation.