

6253 Heavy Duty Foot Potentiometer **herga**

Technology Ltd

- Choice of 5K and 10K potentiometer
- Sturdy durable industrial footswitch with distinctive styling
- Available in many different colors
- Customer colours and logos available on request
- Special designs according to customer specifications
- Cover with plenty of room for safety shoes
- average life expectancy 1 x 10⁶ operations
- Waterproof EN 60529 IP 67 (IP 68 on request)



Outline dimensions

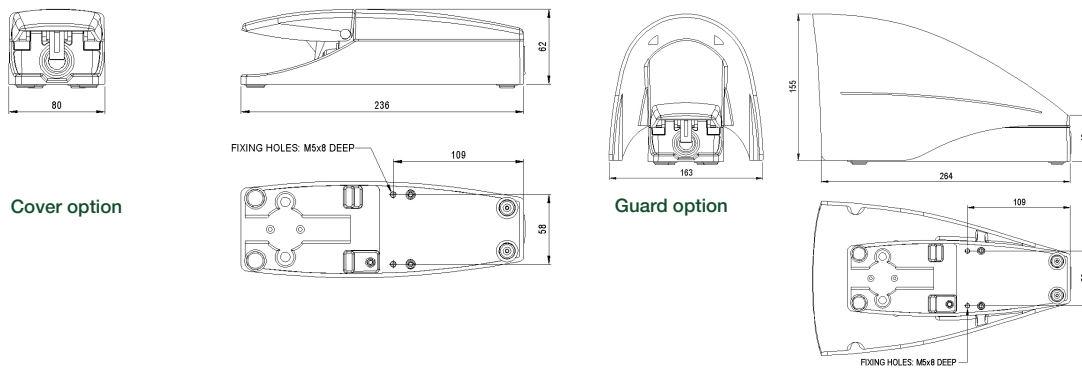

Ordering and options

Stock model : 6253-BAAA-AAZ0

6253 - [] [] [] **A** - [] [] **Z** **0**

Model

Cover and guard colours

- | | |
|----------------|----------------|
| A Cover Yellow | B Guard Yellow |
| C Cover White | D Guard White |
| E Cover Blue | F Guard Blue |
| G Cover Orange | H Guard Orange |

Base colour

- | | |
|---------|---------|
| A Black | B White |
|---------|---------|

Thread / hole information

- A Single back entry M20 gland thread

Tread colour

- A Black

Action - First letter denotes the action, second letter denotes the electrical rating in the next section. (NB: the choice of action dictates the electrical rating)

- AA 5.0 kΩ potentiometer DPCO, Snap action switches at start of pedal depression
- BB 10.0 kΩ potentiometer DPCO, Snap action switches,

Electrical rating

- A Switch Rating 21A 250V AC, 1HP 125V AC, 2HP 250V AC, Potentiometer Rating: Resistance 5KΩ Power Max 0.5W Voltage Max 50V
- B Switch Rating 21A 250V AC, 1HP 125V AC, 2HP 250V AC Potentiometer Rating: Resistance 10KΩ

Emergency stop

- Z No emergency stop fitted

Initial depression of the foot pedal causes both Microswitch contacts to change state and further depression creates a resistance change in the potentiometer



Herga Technology Ltd - Northern Way - Bury St. Edmunds - Suffolk - IP32 6NN - UK
 sales@herga.com • www.herga.com • +44 (0)1284 701422

Subject to change without notice

6253 Heavy Duty Foot Potentiometer **herga**

Technology Ltd

General specifications

Standards/approvals	Standards: EN 60730, EN 61058, Microswitch Approvals: CE, BEAB, CSA, DEMCO, IMQ, KEMA, NEMCO, OVE, SEMCO, SETI, SEV, UL and VDE	Operating temperature range	-5°C to +40°C
Degree of protection	EN 60529 IP67 (IP68 upon request)	Body material	Die cast aluminium
Connection method	Screw terminals, stripped cable cores or connector of your choice	Weight	Cover/unguarded 1Kg or 1.5Kg guarded
		Average mechanical life	1 x 10 ⁶ operations
		Additional information	Other potentiometer resistance values from 1K Ω to 10k Ω can be applied in medium batch volumes, although these versions cannot be supplied with microswitch contacts

Potentiometer and switch specifications

Electrical switches

Average life expectancy	Mechanical	1.0 X 10 ⁶		
	Electrical	2.0 x10 ⁵ @ 10A 2.0 x10 ⁵ @ 21A		
Max. electrical load	Voltage (V)	Resistive (A)	Inductive (A)	Motor (Pf0.75)
	AC	250	21	8
DC	250	21		
	125	21		
	6	21	21	
	12	15	15	
	24	8	7	
	60	1	0.5	
	110	0.5	0.2	
	220	0.25	0.1	

Potentiometer - electrical data	5 k Ω	10 k Ω
Resistance tolerance	+/- 20%	
Linearity	+/- 1%	
Recommended wiper current	<0.1 μ A	
Power rating	0.5W/40°C	
Max. wiper fault current	10mA	
Max. potentiometer rating	50V	70V
Dielectric strength	1000 VAC	
Resistance	Conductive plastic	

Dry Switching: If switching low power circuits i.e. low current (4 to 100 mA) and low voltage (below 30V), consult herga for further advice.

In all applications except where protective extra low voltage (PELV) circuits are being switched, an earth conductor must be installed. The earth conductor should be rated in accordance with the prevailing standards