



立得電子工業股份有限公司
SPECIFICATION FOR LED BACKLIGHT

PART NO. : LP1033-UB91-S207-1

VERSION. : C

DATE. : 2004.12.18

Approved by: _____

Checked by: _____

Prepared by: _____

LEDTECH ELECTRONICS CORPORATION

NANYA ROAD, MUGANG, ZHAOQING CITY

GUANGDONG CHINA.

TEL:86-758-2875541,2870651,2877464,2876185,2877017

FAX:86-758-2878014

Http:www.ledtech.com.tw

◆ Features

Free Design.

High Brightness.

Longer Life And Low Power Consumption.

Various Color: Yellow Green , Amber , Red , Orange , Green ,Blue...

Dimensions:71x24.5x3(mm)

View Area:61x22.5(mm)

◆ Radiative Sort

Bottom Backlight



V Edge Backlight

◆ Chip Material

GaP



V AlGaInP



InGaN



GaAlAs

◆ Applications

LCD Backlight

Meterpanel Backlight

PDA

Mobile Phone

◆ Chip Emitting Color:

YELLOW

◆ Absolute Maximum Rating

Parameter	Symbol	Rating	Unit	Remark
Forward Current	If	25	mA	PRE LED
Reverse Voltage	V _R	5	V	I _R =10uA
Power Dissipation	P _D	240	mW	
Operating Temperature	T _{opr}	-20 ~ +75	°C	
Storage Temperature	T _{sto}	-30 ~ +85	°C	
Soldering Temperature	T _{sol}	260	°C	5 sec.

◆ **Package Dimensions:**

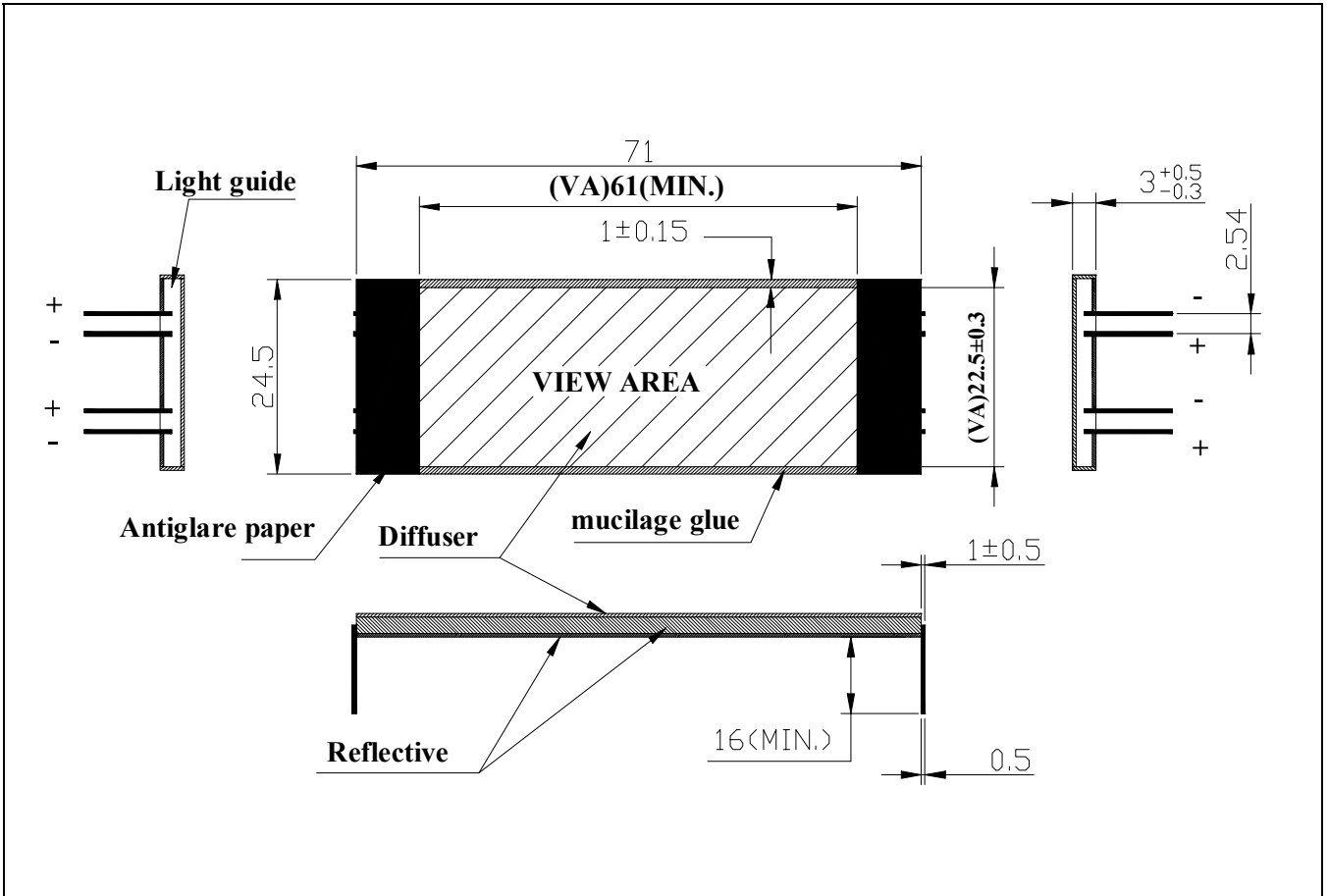

- ◆ **Notes:** All dimensions are in millimeters.
Tolerance is ±0.30mm unless otherwise noted.

◆ **Circuit Diagram**

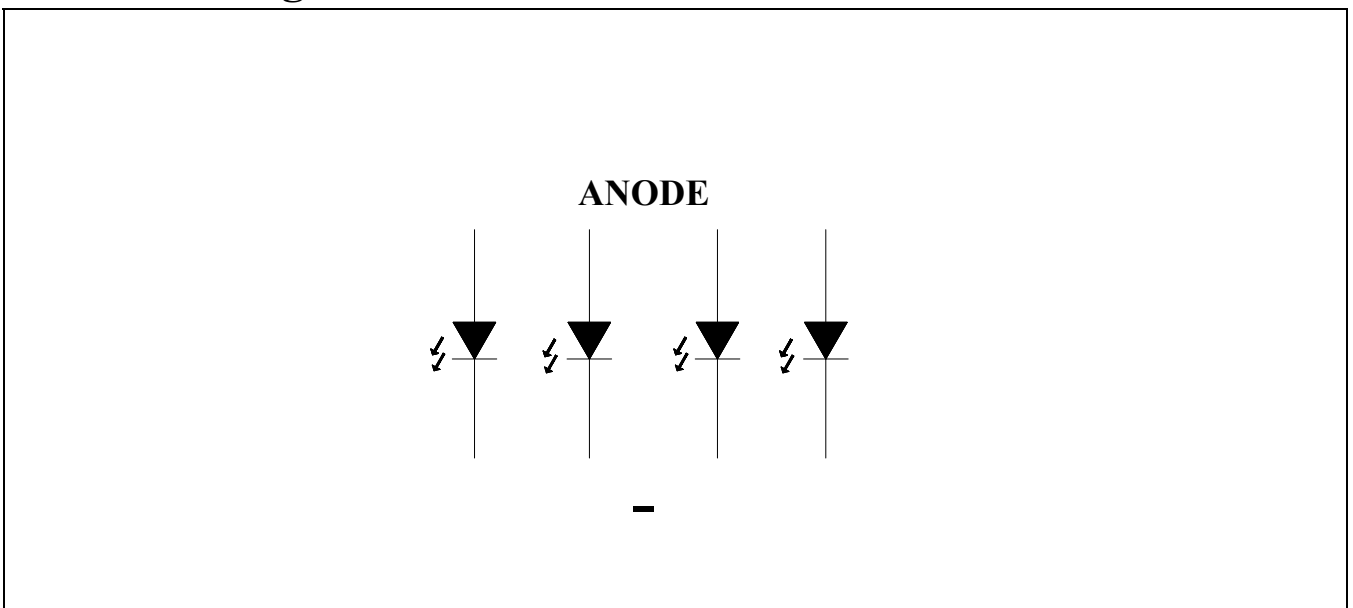

◆ Electro/Optical Characteristics(at Ta=25°C)

Parameter	Symbol	Test Condition	Rating			Unit	Remark
			Min	Typ	Max		
Forward Voltage	V _f	I _f =5mA PER LED	1.7	1.8	2.1	V	★ 1
Luminous Intensity	I _v	I _f =5mA PER LED				cd/m ²	★2
			50	75		LUX	
Luminous Tolerance	-	I _f =5mA PER LED	-	-	30	%	★2,★3
Emission Wavelength	λ _d	I _f =5mA PER LED	586	591	596	nm	
Spectral Line Half Width	Δλ	I _f =5mA PER LED	-	15	-	nm	

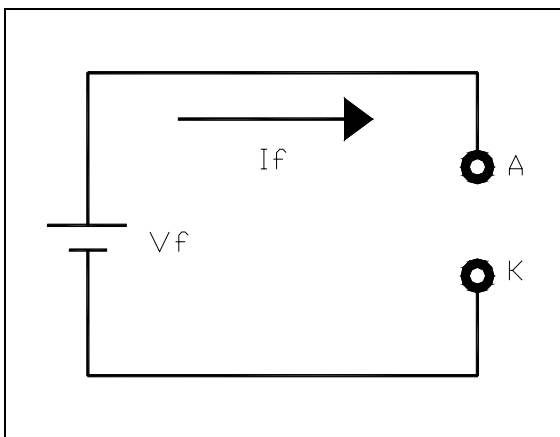
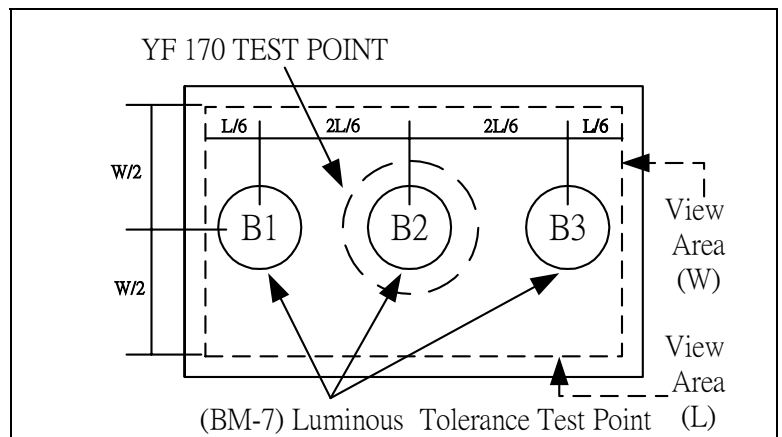
Remark
★1. Testing Method

★2. Measured Method

★3. TEST METHOD

$$\text{Position of luminous tolerance} = \frac{B(\text{MAX.}) - B(\text{MIN.})}{B(\text{MAX.})} \times 100\%$$

◆ Package methods:

During shipment and storage , the methods must not affect the product's quality ◦

- Inner package: (1) poly foam , sponge , air bubble ◦
(2)PBC vacuum package material ◦
- Outer package: Hard paper box ◦

**X PRODUCTS
IN ONE PVC
(QTY:X)**

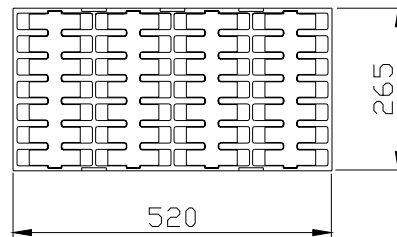

**Y PVC
per box
(QTY:YX)**

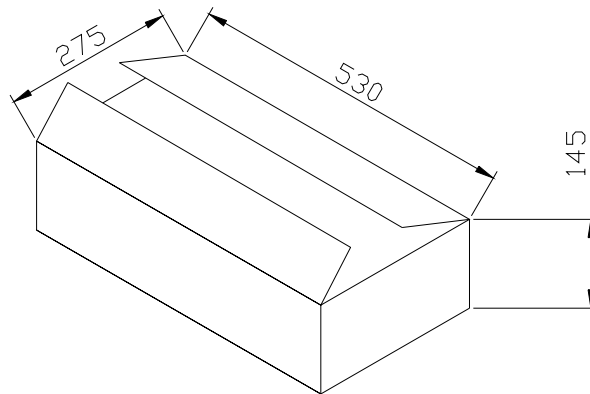

**2 Boxes
per carton
(QTY:2YX)**

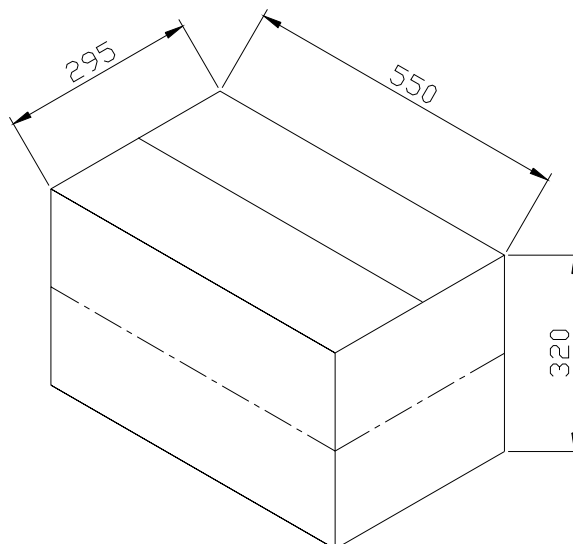

Project Changes

Date	Content
2004/12/17	回收 A 版,發行 B 版
2004/12/18	回收 B 版,發行 C 版