



LEDTECH ELECTRONICS CORP.

NANYA ROAD, MUGANG ZHAOQING  
CITY GUANGDONG CHINA.

TEL: 86-758-2875541, 2870651, 2877464, 2876185, 2877017

FAX: 86-758-2878014

[Http://www.ledtech.com.tw](http://www.ledtech.com.tw)

# SPECIFICATION

*PART NO. : LT6U23-AH-UDC9-S50*  
HIGH POWER AUTOMATIVE LED



Approved by

Checked by

Prepared by

*Tung*

*Lian*

*Yu Fang*

### Package Dimensions

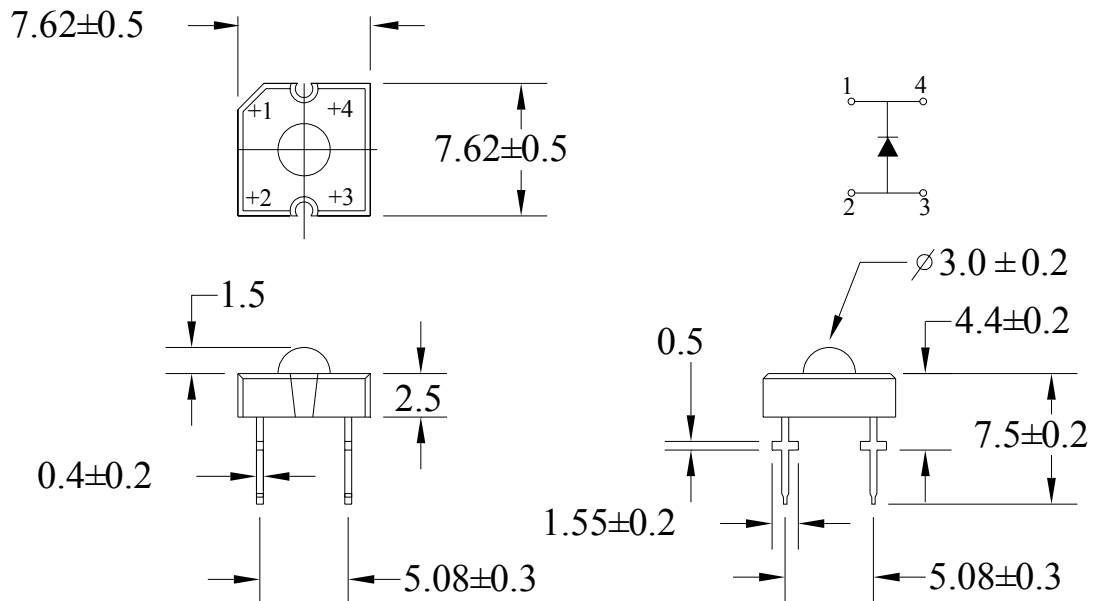

#### Notes:

1. All dimensions are in mm.
2. Tolerance is  $\pm 0.25$  mm unless otherwise noted

### Description

Part No.	LED Chip		Lens Color
	Material	Emitting Color	
LT6U23-AH-UDC9-S50	InGaN/Sapphire	True Green	Water Clear