



LEDTECH ELECTRONICS CORP.

NANYA ROAD, MUGANG ZHAOQING
CITY GUANGDONG CHINA.

TEL: 86-758-2875541, 2870651, 2877464, 2876185, 2877017

FAX: 86-758-2878014

[Http://www.ledtech.com.tw](http://www.ledtech.com.tw)

SPECIFICATION

PART NO. : LP30NR-S089

COB 50X50mm TYPE



Approved by

Checked by

Prepared by

王方波

蘇智良

顏保宏



Features

- Pb-Free soldering application
- RoHS compliance
- Multi-Chip package
- High Reliability

Application

- Bay-light module
- Indoor decorative lighting
- Illumination
- Automotive Application
- Architectural Lighting
- Indicator / Decoration

Package Dimensions

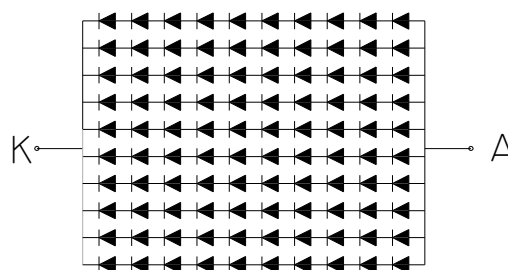
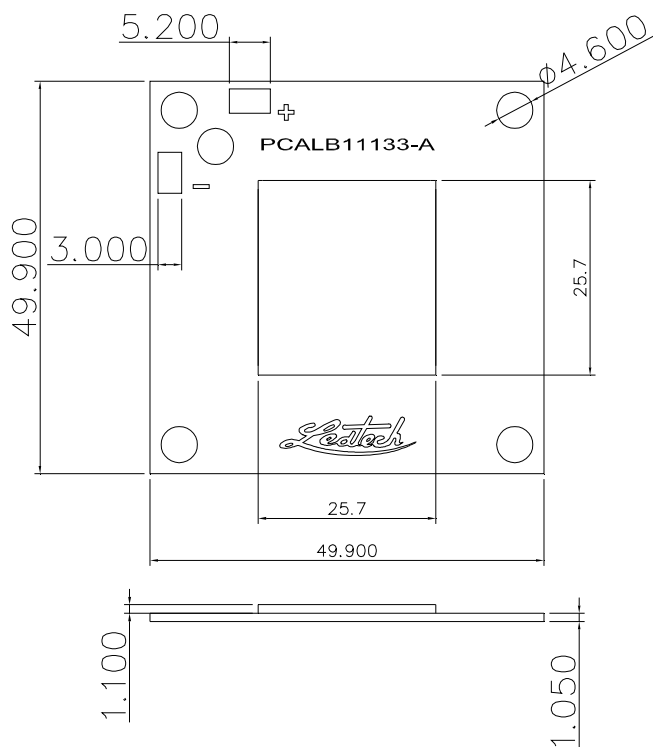

Notes:

1. All dimensions are in mm.
2. Tolerance is $\pm 0.5\text{mm}$ unless otherwise noted.

Description

Part No.	LED Chip		Lens Color
	Material	Emitting Color	
LP30NR-S089	InGaN/ Sapphire	Warm White	Orange Diffused

Absolute Maximum Ratings at Ta=25 °C

Parameter	Symbol	Rating	Unit
Power Dissipation	P _D	32.4	W
D.C. Forward Current	I _f	900	mA
Peak Current(1/10Duty Cycle,0.1ms Pulse Width.)	I _f (Peak)	950	mA
Operating Temperature Range	T _{opr.}	-40 to +100	°C
Storage Temperature Range	T _{stg.}	-40 to +100	°C
Solder Heat Resistance	SHR	Hand Soldering:300±5°C for 3 sec.	
Electric Static Discharge Threshold (HBM)	ESD	1000	V

Electrical and Optical Characteristics:

Parameter	Symbol	Condition	Min.	Typ.	Max.	Unit
Luminous Flux		I _f =900mA	-	2200	-	lm
	Rank 01		1900	-	2400	
	Rank 02		2400	-	2900	
Forward Voltage		I _f =900mA	-	30.6	-	V
	Rank U07		28	-	32	
	Rank U08		32	-	36	
CIE Chromaticity Coordinates : X Axis	X	I _f =900mA	-	0.4338	-	
CIE Chromaticity Coordinates : X Axis	Y	I _f =900mA	-	0.403	-	
Correlated Color Temperature	CCT	I _f =900mA	2875	-	3200	°K
Color Rendering Index	CRI	I _f =900mA	-	75	-	R _a
Reverse Current	I _r	V _r =5V	-	-	100	μA
Viewing Angle	2θ 1/2	I _f =900mA	-	120	-	deg
Thermal Resistance Junction to Case	Rθ _{J-C}	I _f =900mA	-	15	-	°C/W

Notes:

1. The datas tested by IS tester.
2. Customer's special requirements are also welcome.

Chromaticity Coordinates Specifications for Bin Grading:

COLOR RANKS (.Ta=25°C)

WARM WHITE

BIN	RANK				
7A	X	0.4147	0.4221	0.4342	0.4259
	Y	0.3814	0.3984	0.4028	0.3853
7B	X	0.4221	0.4299	0.4430	0.4342
	Y	0.3984	0.4165	0.4212	0.4028
7C	X	0.4342	0.4430	0.4562	0.4465
	Y	0.4028	0.4212	0.4260	0.4071
7D	X	0.4259	0.4342	0.4465	0.4373
	Y	0.3853	0.4028	0.4071	0.3893

Note: X,Y Tolerance each Bin limit is±0.01.

Chromaticity Coordinates & Bin grading diagram:

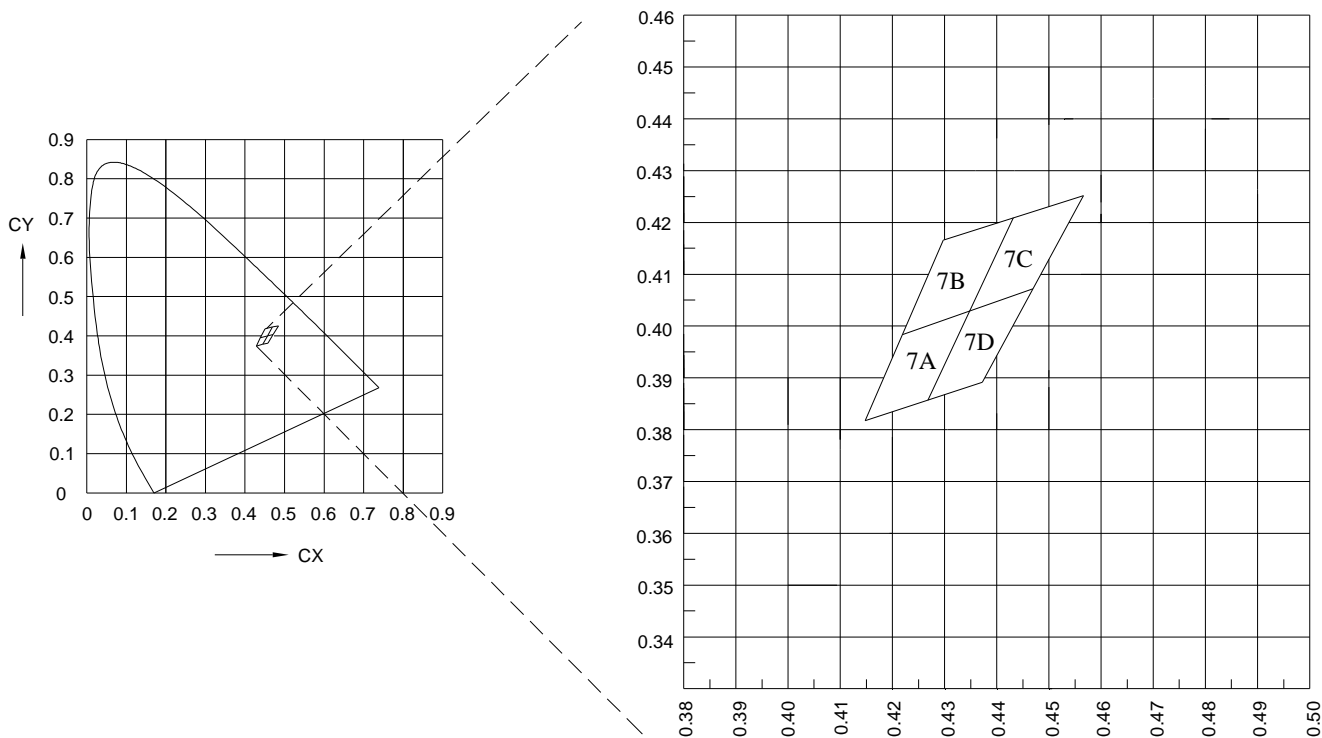

Typical Electrical/Optical Characteristic Curves

(25°C Ambient Temperature Unless Otherwise Noted)

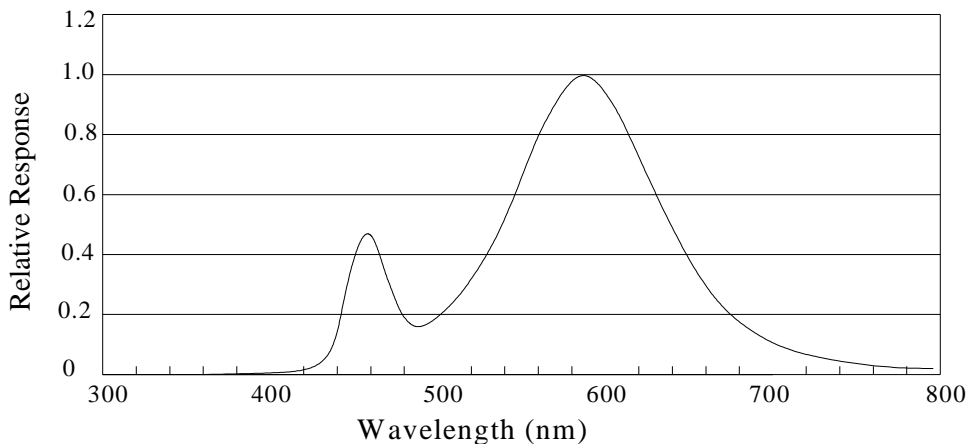
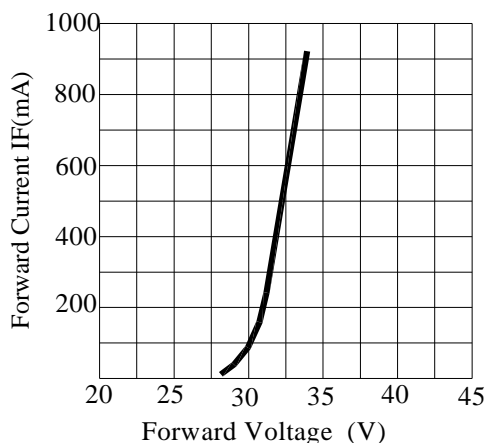
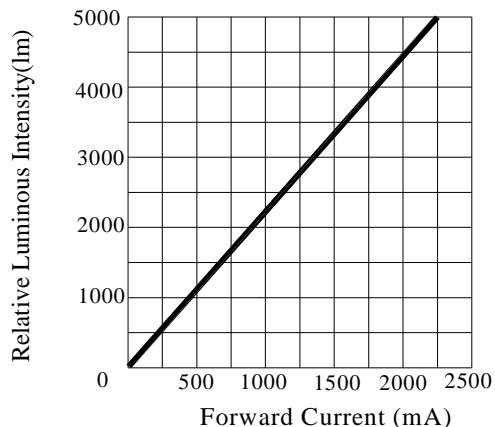

Fig.1 WHITE LED Spectrum VS. WAVELENGTH



Forward Current VS. Applied Voltage



Forward Current VS. Luminous Intensity

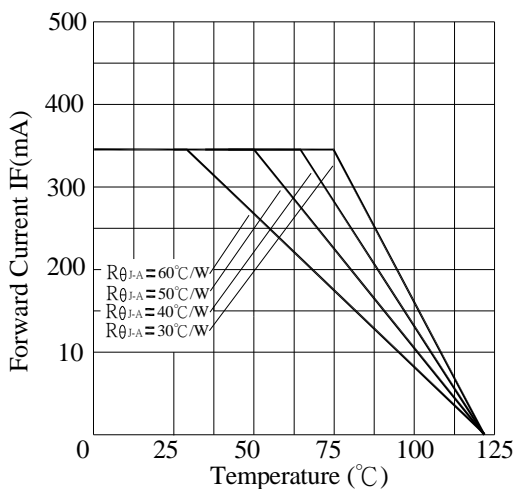

Ambient Temperature VS. Forward Current

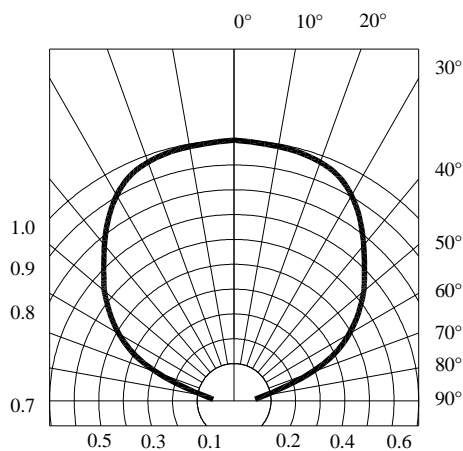

Radiation Diagram

Handling of Silicone Resin LEDs

Handling Indications

During processing, mechanical stress on the surface should be minimized as much as possible. Sharp objects of all types should not be used to pierce the sealing compound

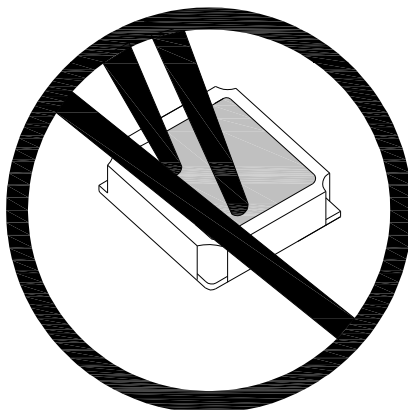

Figure 1

In general, LEDs should only be handled from the side. By the way, this also applies to LEDs without a silicone sealant, since the surface can also become scratched.

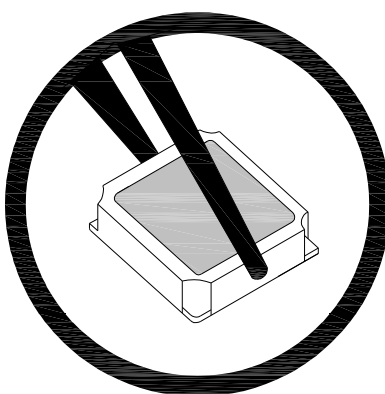
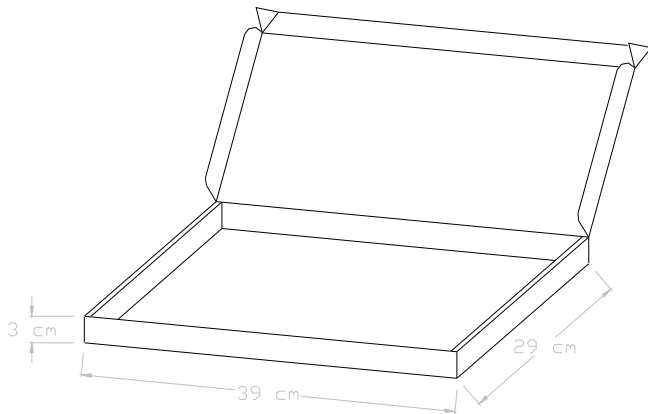
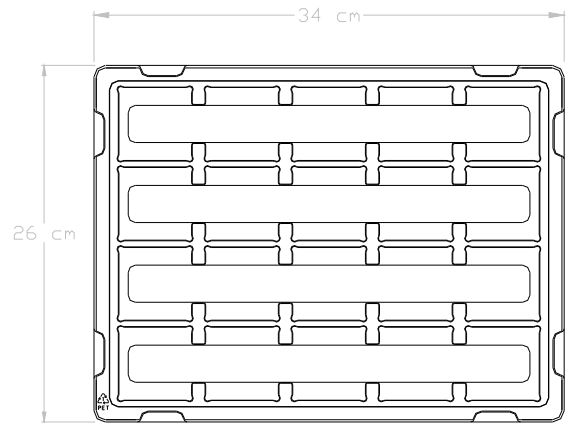
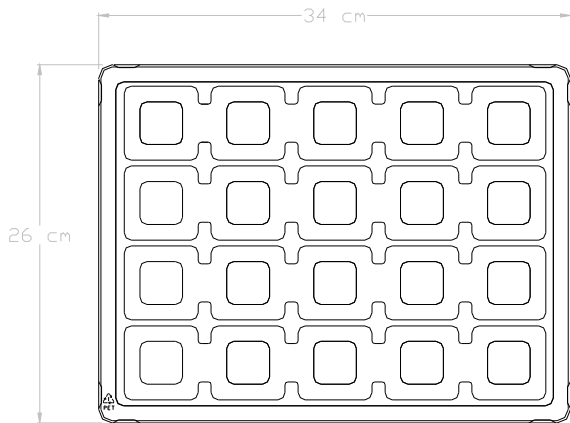

Figure 2

When populating boards in SMT production, there are basically no restrictions regarding the form of the pick and place nozzle, except that mechanical pressure on the surface of the resin must be prevented. This is assured by choosing a pick and place nozzle which is larger than the LED's reflector area.

Tray packaging



Inner box

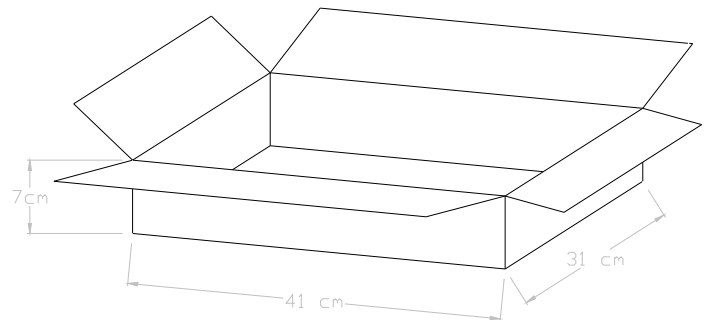

Outer box

Notes :

1. All dimensions are in mm.
2. There are 20pcs in a tray.
3. There are 2trays in an inner box.
4. There are 2 inner boxes in an outer box.