



LEDTECH ELECTRONICS CORP.

NANYA ROAD, MUGANG ZHAOQING
CITY GUANGDONG CHINA.

TEL: 86-758-2875541, 2870651, 2877464, 2876185, 2877017

FAX: 86-758-2878014

[Http://www.ledtech.com.tw](http://www.ledtech.com.tw)

SPECIFICATION

PART NO. : LP30NR-S002

10W HIGH POWER LED



Approved by

Checked by

Prepared by

Gary

Chih Liang

Eva Chang

**Features**

- Pb-Free soldering application
- RoHS compliance
- Multi-Chip package
- High Reliability

Application

- Bulb
- Indoor decoration lighting
- Reading lights
- Portable flashlight

Package Dimensions

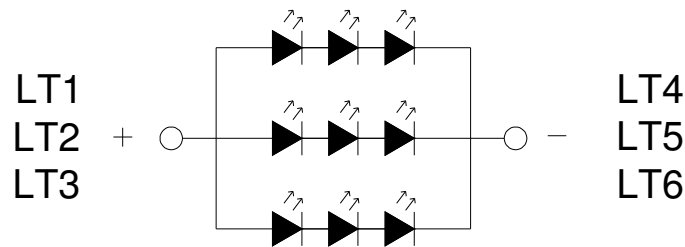
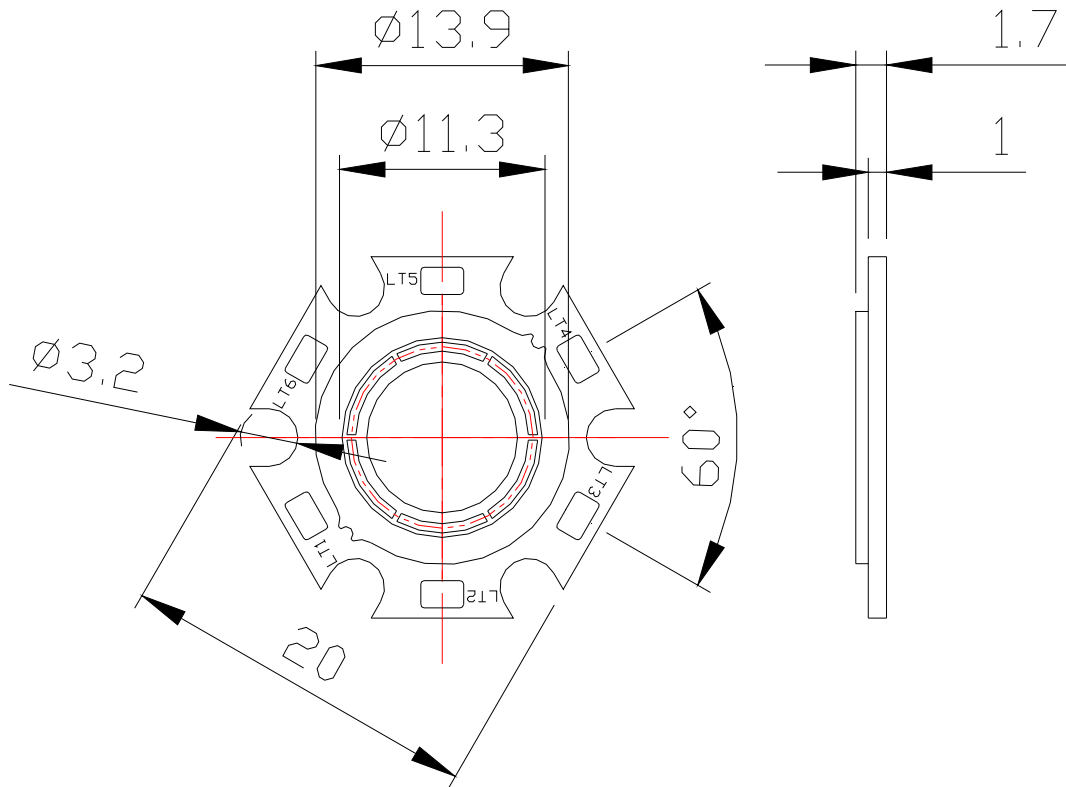

Notes:

- 1.All dimensions are in mm.
- 2.Tolerance is +/-0.6mm unless otherwise noted.

Description

Part NO.	LED Chip		Lens Color
	Material	Color Coordinates	
LP30NR-S002	InGaN/Sapphire	Warm White	Yellow Diffused

Absolute Maximum Ratings at Ta=25°C :

Parameter	Symbol	Rating	Unit
Power Dissipation ★	Pd	1260	mW
LED Junction Temperature★	Tj	120	°C
Reverse Voltage ★	Vr	5	V
D.C. Forward Current ★	If	350	mA
Peak Current(1/10Duty Cycle,0.1ms Pulse Width.) ★	If(Peak)	500	mA
Storage Temperature Range	Tstg.	-40 to +85	°C
Soldering Temperature	Tsld.	Reflow Soldering: 260°C for 10 sec. Hand Soldering: 350°C for 3 sec.	
Electric Static Discharge Threshold (HBM) ★	ESD	300	V

★ The value are based on 1 die performance.

Electrical and Optical Characteristics :

Parameter	Symbol	Condition	Values			Units	
			Min.	Typ.	Max.		
Luminous Flux	--	IF=1050mA	550	650	--	lm	
	Rank L1		550	--	650		
	Rank L2		650	--	750		
Forward voltage	--	VF	IF=1050mA	--	9.5	--	V
	Rank V1			9.00	--	9.50	
	Rank V2			9.51	--	10.00	
	Rank V3			10.01	--	10.50	
Correlated Colour Temperature	CCT	IF=1050mA	2875	3000	--	K	
CIE Chromaticity Coordinates: X Axis	X	IF=1050mA		0.4338			
CIE Chromaticity Coordinates: Y Axis	Y	IF=1050mA		0.4030			
Reverse Current	IR	Vr=5V	--	--	50	μA	
Color Renderig Index	CRI	IF=1050mA	--	74	--	Ra	
Viewing angle at 50% IV		2θ1/2	--	120	--	Deg.	
Thermal Resistance Junction to Case		RθJ-C	--	15	--	°C/W	

Notes :

1. The datas tested by IS tester.
2. Customer's special requirements are also welcome

Typical Electrical/Optical Characteristic Curves
 (25°C Ambient Temperature Unless Otherwise Noted)

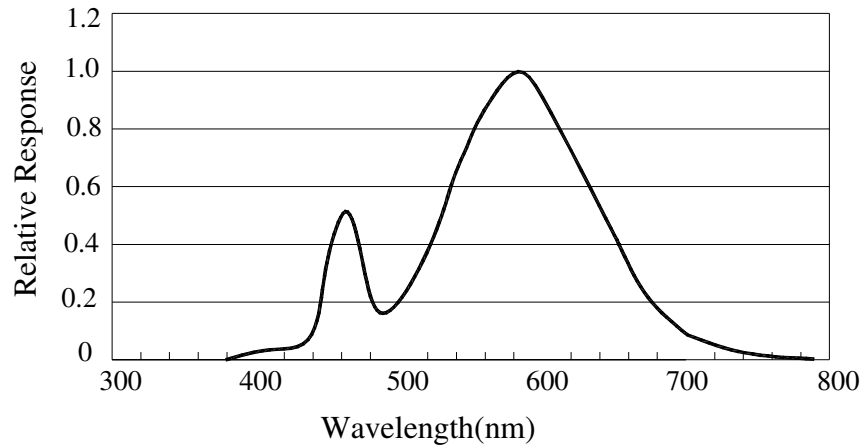
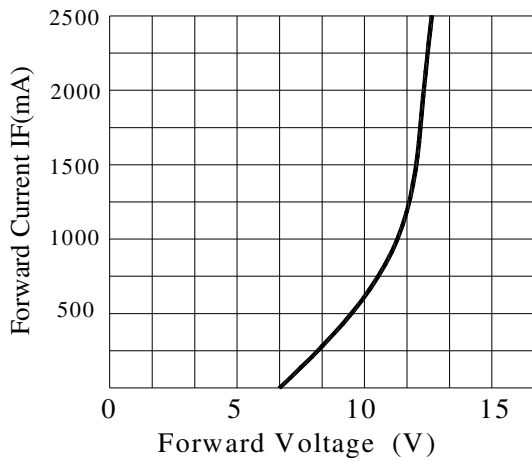
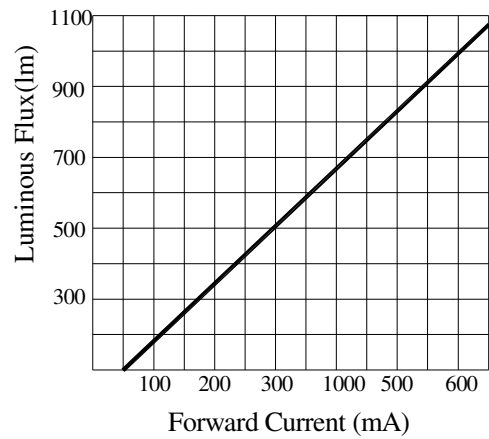

Fig.1 WARM WHITE LED Spectrum VS. WAVELENGTH



Forward Current VS. Applied Voltage



Forward Current VS. Luminous Flux

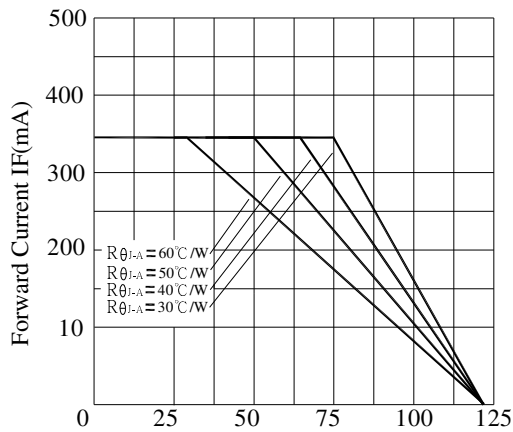

Ambient Temperature VS. Forward Current

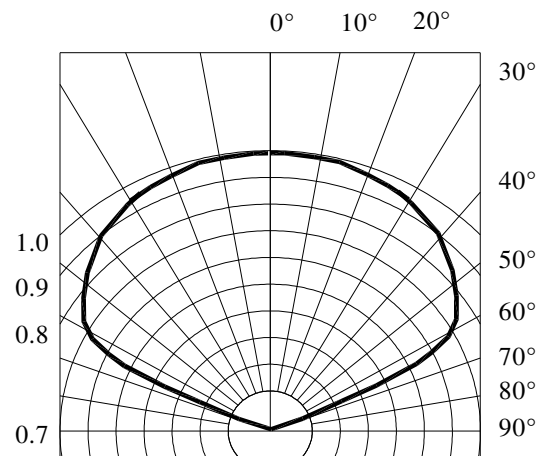

Radiation Diagram

Chromaticity Coordinates Specifications for Bin Grading:

COLOR RANKS (IF=1050mA.Ta=25°C)

BIN	RANK				
7A	X	0.4147	0.4221	0.4342	0.4259
	Y	0.3814	0.3984	0.4028	0.3853
7B	X	0.4221	0.4299	0.4430	0.4342
	Y	0.3984	0.4165	0.4212	0.4028
7C	X	0.4342	0.4430	0.4562	0.4465
	Y	0.4028	0.4212	0.4260	0.4071
7D	X	0.4259	0.4342	0.4465	0.4373
	Y	0.3853	0.4028	0.4071	0.3893

Note: X.Y Tolerance each Bin limit is ± 0.01 .

Chromaticity Coordinates & Bin grading diagram:

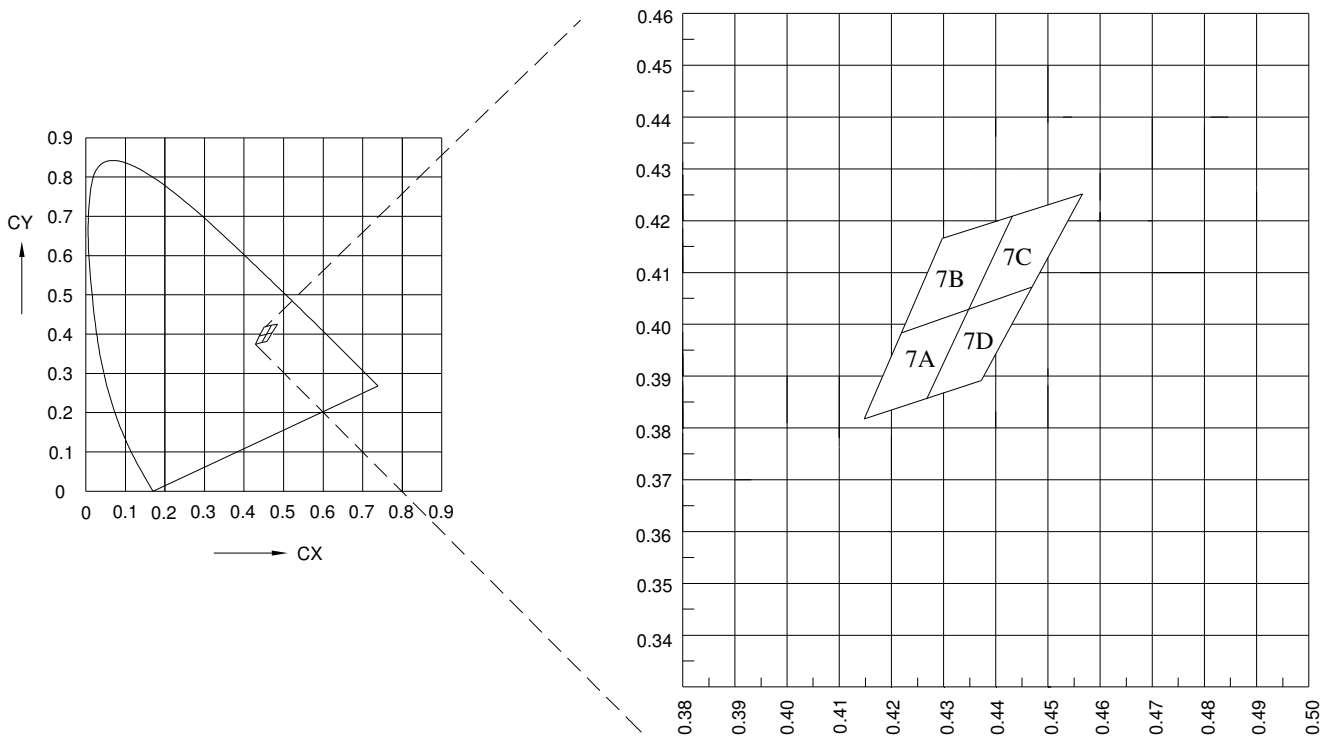

Tray packaging

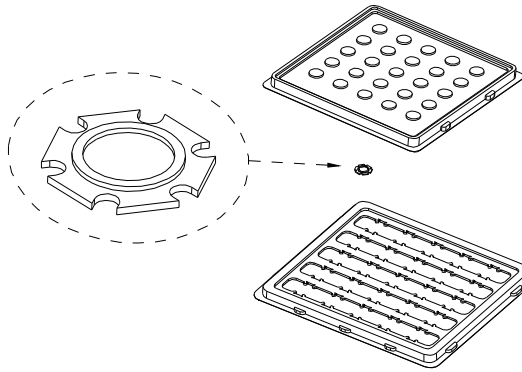

25 PCS LED / 1 TRAY

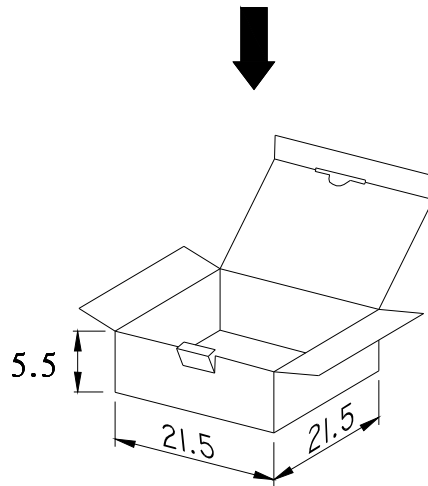

4 PCS TRAY / 1 INNER BOX

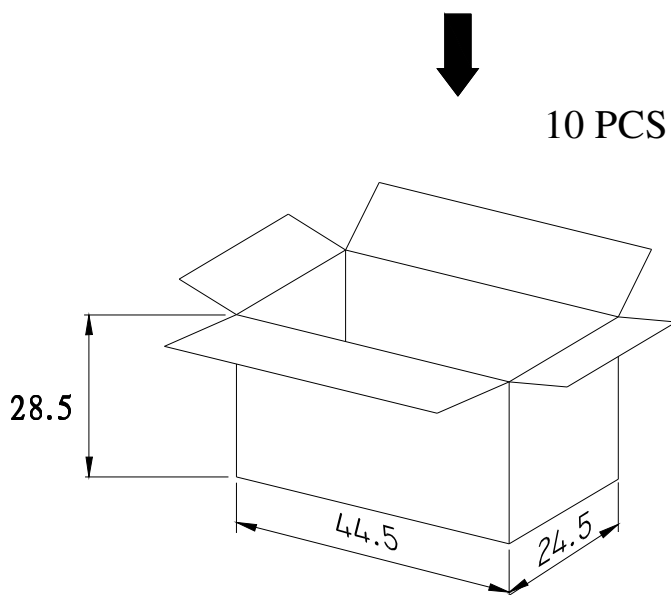

10 PCS INNER BOX / 1 OUTER BOX

UNIT : cm

Handling of Silicone Resin LEDs

Handling Indications

During processing, mechanical stress on the surface should be minimized as much as possible. Sharp objects of all types should not be used to pierce the sealing compound

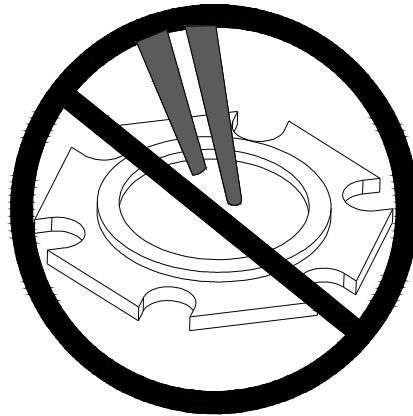

Figure 1

In general, LEDs should only be handled from the side. By the way, this also applies to LEDs without a silicone sealant, since the surface can also become scratched.

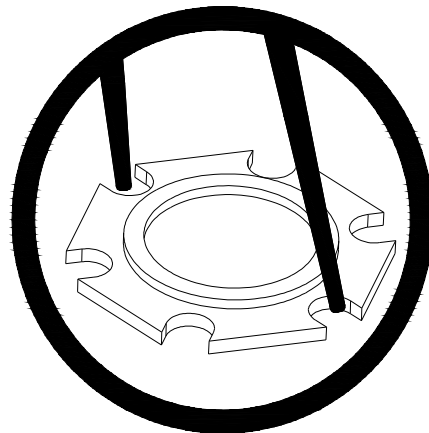

Figure 2

When populating boards in SMT production, there are basically no restrictions regarding the form of the pick and place nozzle, except that mechanical pressure on the surface of the resin must be prevented.

This is assured by choosing a pick and place nozzle which is larger than the LED's reflector area.