



LEDTECH ELECTRONICS CORP.

NANYA ROAD,MUGANG ZHAOQING  
CITY GUANGDONG CHINA.

TEL:86-758-2875541,2870651,2877464,2876185,2877017

FAX:86-758-2878014

[Http://www.ledtech.com.tw](http://www.ledtech.com.tw)

# SPECIFICATION

## COB $\phi$ 25mm TYPE

### *PART NO. : LP30NX-SXXX Series*

	5750-6750K	2875-3200K
3W	LP30N3-S049	LP30NR-S050
4W	LP30N3-S051	LP30NR-S052
6W	LP30N3-S053	LP30NR-S054
9W	LP30N3-S055	LP30NR-S056
12W	LP30N3-S057	LP30NR-S058
15W	LP30N3-S059	LP30NR-S060



Approved by

Checked by

Prepared by

--

--

--





## Features

- Pb-Free soldering application
- RoHS compliance
- Multi-Chip package
- High Reliability

## Application

- Bay-light module
- Indoor decorative lighting
- Illumination
- Automotive Application
- Architectural Lighting
- Indicator / Decoration



**Package Dimensions**

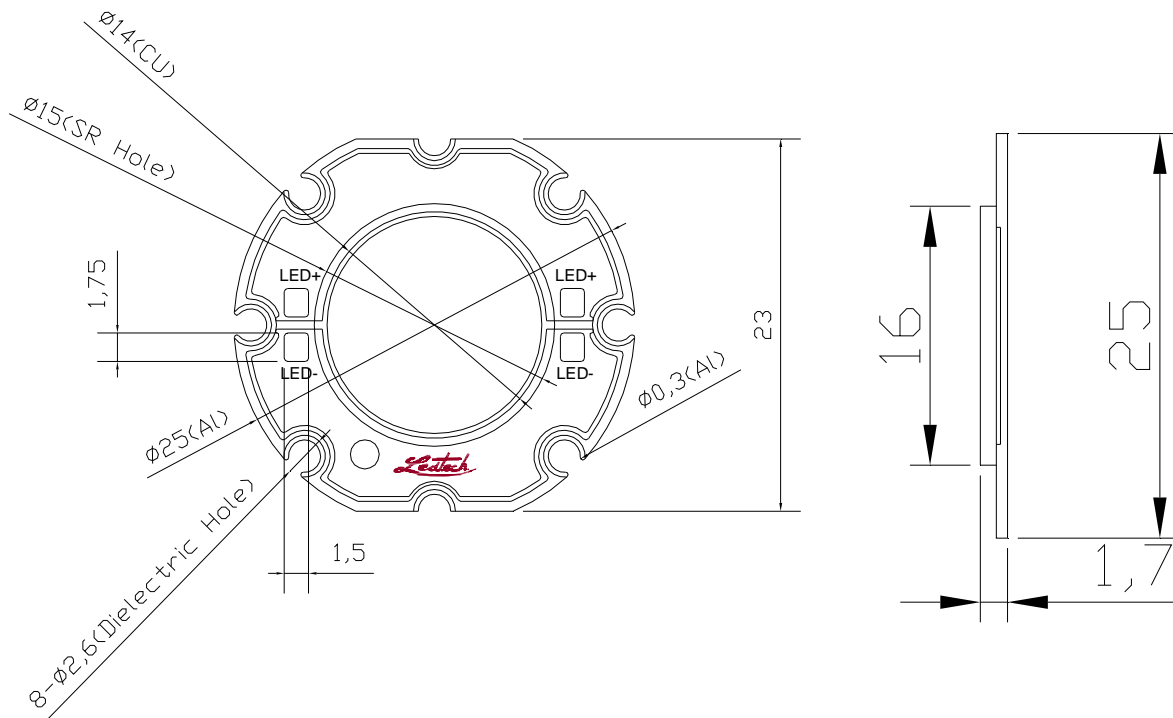

**Notes:**

1. All dimensions are in mm.
2. Tolerance is  $\pm 0.3$ mm unless otherwise noted

**Description**

Part NO.	LED Chip		Lens Color
	Material	Emitting Color	
LP30NX-SXXX	InGaN/Sapphire	White	Yellow Diffused
		Warm White	Orange Diffused

### Circuitry

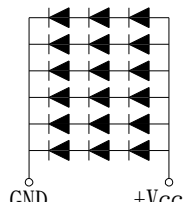
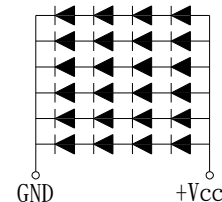
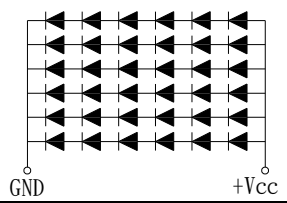
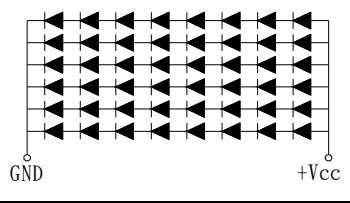
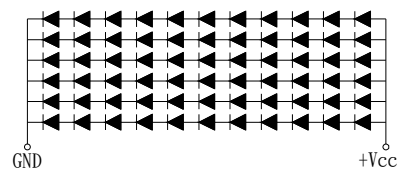
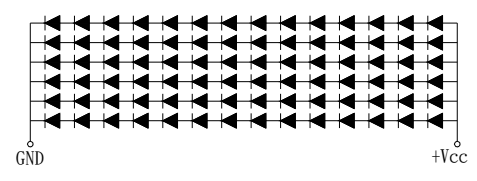
<b>3W</b>		<b>4W</b>	
	LP30N3-S049 LP30NR-S050		LP30N3-S051 LP30NR-S052
<b>6W</b>		<b>9W</b>	
	LP30N3-S053 LP30NR-S054		LP30N3-S055 LP30NR-S056
<b>12W</b>		<b>15W</b>	
	LP30N3-S057 LP30NR-S058		LP30N3-S059 LP30NR-S060

### Absolute Maximum Ratings at Ta=25°C :

Parameter	Symbol	Rating	Unit
LED Junction Temperature	T <sub>j</sub>	120	°C
Reverse Voltage ★	V <sub>r</sub>	5	V
D.C. Forward Current	I <sub>f</sub>	350	mA
Storage Temperature Range	T <sub>stg.</sub>	-40 to +85	°C
Soldering Temperature	T <sub>sl.</sub>	Hand Soldering: 350°C for 5 sec.	
Electric Static Discharge Threshold (HBM) ★	ESD	1000	V

★ The value are based on 1 die performance.



**LP30NX-SXXX**  
Series

COB  $\phi$  25mm TYPE

**Electrical and Optical Characteristics :**

**3W LP30N3-S049**

Parameter	Symbol	Condition	Values			Units	
			Min.	Typ.	Max.		
Luminous Flux		$\Phi_v$	IF=350mA	--	350	--	lm
	Rank L1			200	--	400	
	Rank L2			400	--	600	
Forward voltage		VF	IF=350mA	--	9.5	--	V
	Rank V1			8	--	10	
	Rank V2			10	--	12	
Correlated Color Temperature	CCT	IF=350mA	5750	--	6750	K	
CIE Chromaticity Coordinates: X Axis	X	IF=350mA	--	0.3123	--		
CIE Chromaticity Coordinates: Y Axis	Y	IF=350mA	--	0.3282	--		
Reverse Current	$I_R$	$V_r=5V$	--	--	50	$\mu A$	
Color Rendering Index	CRI	IF=350mA	--	75	--	Ra	
Viewing angle at 50% IV		2 $\theta$ 1/2	--	120	--	Deg.	

**3W LP30NR-S050**

Parameter	Symbol	Condition	Values			Units	
			Min.	Typ.	Max.		
Luminous Flux		$\Phi_v$	IF=350mA	--	320	--	lm
	Rank L1			200	--	400	
	Rank L2			400	--	600	
Forward voltage		VF	IF=350mA	--	9.5	--	V
	Rank V1			8	--	10	
	Rank V2			10	--	12	
Correlated Color Temperature	CCT	IF=350mA	2875	--	3200	--	
CIE Chromaticity Coordinates: X Axis	X	IF=350mA		0.4338		--	
CIE Chromaticity Coordinates: Y Axis	Y	IF=350mA		0.4030		--	
Reverse Current	$I_R$	$V_r=5V$	--	--	50	$\mu A$	
Color Rendering Index	CRI	IF=350mA	--	75	--	Ra	
Viewing angle at 50% IV		2 $\theta$ 1/2	--	120	--	Deg.	

**Notes :**

1. The data tested by IS tester.
2. Customer's special requirements are also welcome



**LP30NX-SXXX**  
Series

COB  $\phi$  25mm TYPE

**Electrical and Optical Characteristics :**

**4W LP30N3-S051**

Parameter	Symbol	Condition	Values			Units	
			Min.	Typ.	Max.		
Luminous Flux		$\Phi_v$	IF=350mA	--	470	--	lm
	Rank L1			350	--	550	
	Rank L2			550	--	750	
Forward voltage		VF	IF=350mA	--	12.7	--	V
	Rank V1			11	--	13	
	Rank V2			13	--	15	
Correlated Color Temperature	CCT	IF=350mA	5750	--	6750	K	
CIE Chromaticity Coordinates: X Axis	X	IF=350mA	--	0.3175	--		
CIE Chromaticity Coordinates: Y Axis	Y	IF=350mA	--	0.3283	--		
Reverse Current	$I_R$	$V_r=5V$	--	--	50	$\mu A$	
Color Rendering Index	CRI	IF=350mA	--	75	--	Ra	
Viewing angle at 50% IV		2 $\theta$ 1/2	--	120	--	Deg.	

**4W LP30NR-S052**

Parameter	Symbol	Condition	Values			Units	
			Min.	Typ.	Max.		
Luminous Flux		$\Phi_v$	IF=350mA	--	410	--	lm
	Rank L1			350	--	550	
	Rank L2			550	--	750	
Forward voltage		VF	IF=350mA	--	12.7	--	V
	Rank V1			11	--	13	
	Rank V2			13	--	15	
Correlated Color Temperature	CCT	IF=350mA	2875	--	3200	--	
CIE Chromaticity Coordinates: X Axis	X	IF=350mA		0.4338		--	
CIE Chromaticity Coordinates: Y Axis	Y	IF=350mA		0.4030		--	
Reverse Current	$I_R$	$V_r=5V$	--	--	50	$\mu A$	
Color Rendering Index	CRI	IF=350mA	--	75	--	Ra	
Viewing angle at 50% IV		2 $\theta$ 1/2	--	120	--	Deg.	

**Notes :**

1. The data tested by IS tester.
2. Customer's special requirements are also welcome



**LP30NX-SXXX**  
Series

COB  $\phi$  25mm TYPE

**Electrical and Optical Characteristics :**

**6W LP30N3-S053**

Parameter	Symbol	Condition	Values			Units	
			Min.	Typ.	Max.		
Luminous Flux		$\Phi_v$	IF=350mA	--	670	--	lm
	Rank L1			550	--	750	
	Rank L2			750	--	950	
Forward voltage		VF	IF=350mA	--	18.9	--	V
	Rank V1			17	--	19	
	Rank V2			19	--	21	
Correlated Color Temperature	CCT	IF=350mA	5750	--	6750	K	
CIE Chromaticity Coordinates: X Axis	X	IF=350mA	--	0.3175	--		
CIE Chromaticity Coordinates: Y Axis	Y	IF=350mA	--	0.3283	--		
Reverse Current	$I_R$	$V_r=5V$	--	--	50	$\mu A$	
Color Rendering Index	CRI	IF=350mA	--	75	--	Ra	
Viewing angle at 50% IV		2 $\theta$ 1/2	--	120	--	Deg.	

**6W LP30NR-S054**

Parameter	Symbol	Condition	Values			Units	
			Min.	Typ.	Max.		
Luminous Flux		$\Phi_v$	IF=350mA	--	620	--	lm
	Rank L1			550	--	750	
	Rank L2			750	--	950	
Forward voltage		VF	IF=350mA	--	18.9	--	V
	Rank V1			17	--	19	
	Rank V2			19	--	21	
Correlated Color Temperature	CCT	IF=350mA	2875	--	3200	--	
CIE Chromaticity Coordinates: X Axis	X	IF=350mA		0.4338		--	
CIE Chromaticity Coordinates: Y Axis	Y	IF=350mA		0.4030		--	
Reverse Current	$I_R$	$V_r=5V$	--	--	50	$\mu A$	
Color Rendering Index	CRI	IF=350mA	--	75	--	Ra	
Viewing angle at 50% IV		2 $\theta$ 1/2	--	120	--	Deg.	

**Notes :**

1. The data tested by IS tester.
2. Customer's special requirements are also welcome



**LP30NX-SXXX**  
Series

COB  $\phi$  25mm TYPE

**Electrical and Optical Characteristics :**

**9W LP30N3-S055**

Parameter	Symbol	Condition	Values			Units
			Min.	Typ.	Max.	
Luminous Flux		IF=350mA	--	940	--	lm
	Rank L1		700	--	900	
	Rank L2		900	--	1100	
Forward voltage		IF=350mA	--	25	--	V
	Rank V1		23	--	26	
	Rank V2		26	--	29	
Correlated Color Temperature	CCT	IF=350mA	5750	--	6750	K
CIE Chromaticity Coordinates: X Axis	X	IF=350mA	--	0.3175	--	
CIE Chromaticity Coordinates: Y Axis	Y	IF=350mA	--	0.3283	--	
Reverse Current	I <sub>R</sub>	V <sub>r</sub> =5V	--	--	50	$\mu$ A
Color Rendering Index	CRI	IF=350mA	--	75	--	Ra
Viewing angle at 50% IV		2 $\theta$ 1/2	--	120	--	Deg.

**9W LP30NR-S056**

Parameter	Symbol	Condition	Values			Units
			Min.	Typ.	Max.	
Luminous Flux		IF=350mA	--	800	--	lm
	Rank L1		700	--	900	
	Rank L2		900	--	1100	
Forward voltage		IF=350mA	--	25	--	V
	Rank V1		23	--	26	
	Rank V2		26	--	29	
Correlated Color Temperature	CCT	IF=350mA	2875	--	3200	--
CIE Chromaticity Coordinates: X Axis	X	IF=350mA		0.4338		--
CIE Chromaticity Coordinates: Y Axis	Y	IF=350mA		0.4030		--
Reverse Current	I <sub>R</sub>	V <sub>r</sub> =5V	--	--	50	$\mu$ A
Color Rendering Index	CRI	IF=350mA	--	75	--	Ra
Viewing angle at 50% IV		2 $\theta$ 1/2	--	120	--	Deg.

**Notes :**

1. The data tested by IS tester.
2. Customer's special requirements are also welcome



**LP30NX-SXXX**  
Series

COB  $\phi$  25mm TYPE

**Electrical and Optical Characteristics :**

**12W LP30N3-S057**

Parameter	Symbol	Condition	Values			Units	
			Min.	Typ.	Max.		
Luminous Flux		$\Phi_v$	IF=350mA	--	1230	--	lm
	Rank L1			1000	--	1200	
	Rank L2			1200	--	1400	
Forward voltage		VF	IF=350mA	--	35	--	V
	Rank V1			30	--	35	
	Rank V2			35	--	40	
Correlated Color Temperature	CCT	IF=350mA	5750	--	6750	K	
CIE Chromaticity Coordinates: X Axis	X	IF=350mA	--	0.3175	--		
CIE Chromaticity Coordinates: Y Axis	Y	IF=350mA	--	0.3283	--		
Reverse Current	$I_R$	$V_r=5V$	--	--	50	$\mu A$	
Color Rendering Index	CRI	IF=350mA	--	75	--	Ra	
Viewing angle at 50% IV		2 $\theta$ 1/2	--	120	--	Deg.	

**12W LP30NR-S058**

Parameter	Symbol	Condition	Values			Units	
			Min.	Typ.	Max.		
Luminous Flux		$\Phi_v$	IF=350mA	--	1100	--	lm
	Rank L1			1000	--	1200	
	Rank L2			1200	--	1400	
Forward voltage		VF	IF=350mA	--	35	--	V
	Rank V1			30	--	35	
	Rank V2			35	--	40	
Correlated Color Temperature	CCT	IF=350mA	2875	--	3200	--	
CIE Chromaticity Coordinates: X Axis	X	IF=350mA		0.4338		--	
CIE Chromaticity Coordinates: Y Axis	Y	IF=350mA		0.4030		--	
Reverse Current	$I_R$	$V_r=5V$	--	--	50	$\mu A$	
Color Rendering Index	CRI	IF=350mA	--	75	--	Ra	
Viewing angle at 50% IV		2 $\theta$ 1/2	--	120	--	Deg.	

**Notes :**

1. The data tested by IS tester.
2. Customer's special requirements are also welcome



**LP30NX-SXXX**  
Series

COB  $\phi$  25mm TYPE

**Electrical and Optical Characteristics :**

**15W LP30N3-S059**

Parameter	Symbol	Condition	Values			Units	
			Min.	Typ.	Max.		
Luminous Flux		$\Phi_v$	IF=350mA	--	1350	--	lm
	Rank L1			1100	--	1400	
	Rank L2			1400	--	1700	
Forward voltage		VF	IF=350mA	--	44.4	--	V
	Rank V1			40	--	45	
	Rank V2			45	--	50	
Correlated Color Temperature	CCT	IF=350mA	5750	--	6750	K	
CIE Chromaticity Coordinates: X Axis	X	IF=350mA	--	0.3175	--		
CIE Chromaticity Coordinates: Y Axis	Y	IF=350mA	--	0.3283	--		
Reverse Current	$I_R$	$V_r=5V$	--	--	50	$\mu A$	
Color Rendering Index	CRI	IF=350mA	--	75	--	Ra	
Viewing angle at 50% IV		2 $\theta$ 1/2	--	120	--	Deg.	

**15W LP30NR-S060**

Parameter	Symbol	Condition	Values			Units	
			Min.	Typ.	Max.		
Luminous Flux		$\Phi_v$	IF=350mA	--	1250	--	lm
	Rank L1			1100	--	1400	
	Rank L2			1400	--	1700	
Forward voltage		VF	IF=350mA	--	44.4	--	V
	Rank V1			40	--	45	
	Rank V2			45	--	50	
Correlated Color Temperature	CCT	IF=350mA	2875	--	3200	--	
CIE Chromaticity Coordinates: X Axis	X	IF=350mA		0.4338		--	
CIE Chromaticity Coordinates: Y Axis	Y	IF=350mA		0.4030		--	
Reverse Current	$I_R$	$V_r=5V$	--	--	50	$\mu A$	
Color Rendering Index	CRI	IF=350mA	--	75	--	Ra	
Viewing angle at 50% IV		2 $\theta$ 1/2	--	120	--	Deg.	

**Notes :**

1. The data tested by IS tester.
2. Customer's special requirements are also welcome

### Typical Electrical/Optical Characteristic Curves

(25°C Ambient Temperature Unless Otherwise Noted)

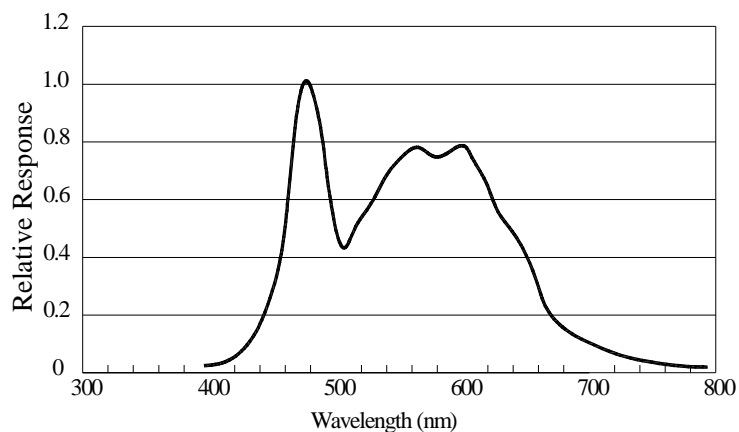

WHITE LED Spectrum VS. WAVELENGTH

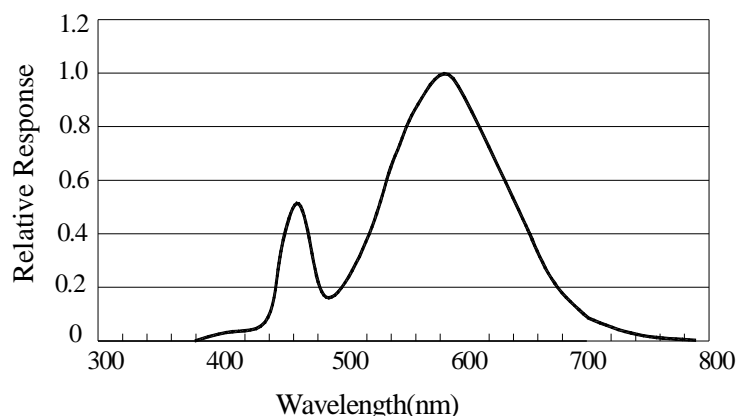

WARM WHITE LED Spectrum VS. WAVELENGTH

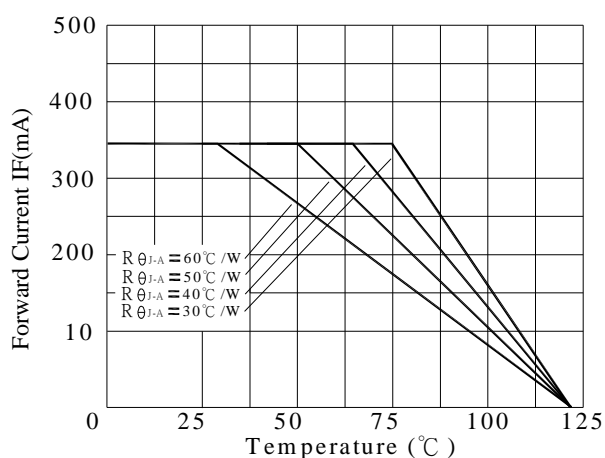

Ambient Temperature VS. Forward Current

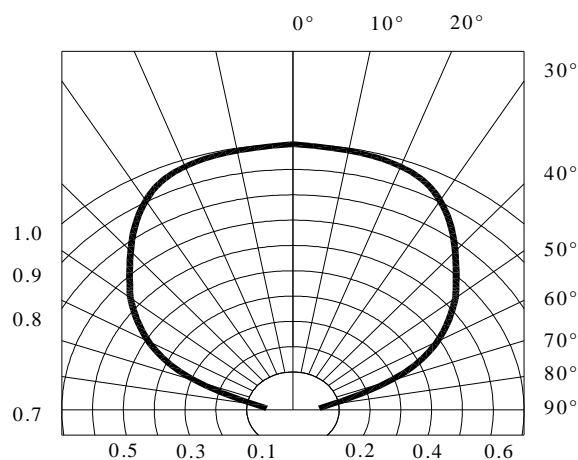

Radiation Diagram

### Chromaticity Coordinates Specifications for Bin Grading:

COLOR RANKS (.Ta=25°C)

#### WHITE

BIN	RANK					BIN	RANK				
WD6	X	0.3210	0.3264	0.3268	0.3218	WD7	X	0.3218	0.3268	0.3272	0.3227
	Y	0.3468	0.3551	0.3430	0.3353		Y	0.3353	0.3430	0.3305	0.3233
WE6	X	0.3164	0.3210	0.3218	0.3175	WE7	X	0.3175	0.3218	0.3227	0.3186
	Y	0.3395	0.3468	0.3353	0.3283		Y	0.3283	0.3353	0.3233	0.3169
WF6	X	0.3122	0.3164	0.3175	0.3136	WF7	X	0.3136	0.3175	0.3186	0.3151
	Y	0.3331	0.3395	0.3283	0.3223		Y	0.3223	0.3283	0.3169	0.3114
WG6	X	0.3085	0.3122	0.3136	0.3100	WG7	X	0.3103	0.3136	0.3151	0.3120
	Y	0.3273	0.3331	0.3223	0.3170		Y	0.3170	0.3223	0.3114	0.3064

Note: X.Y Tolerance each Bin limit is  $\pm 0.01$ .

### Chromaticity Coordinates & Bin grading diagram:

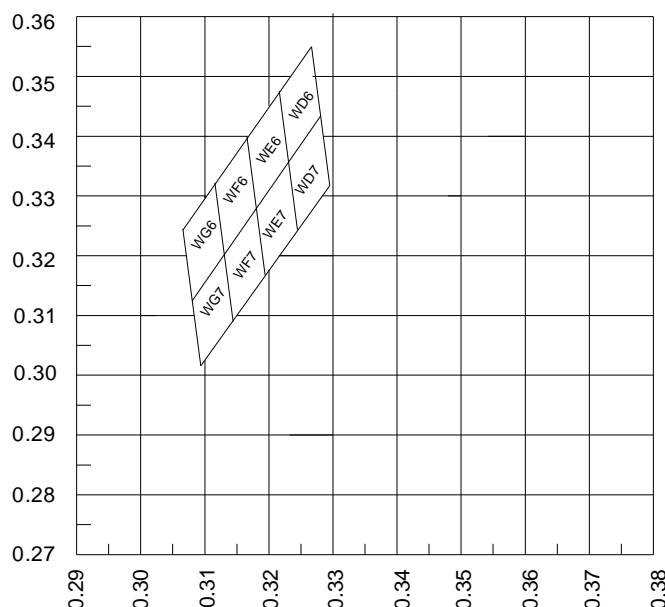
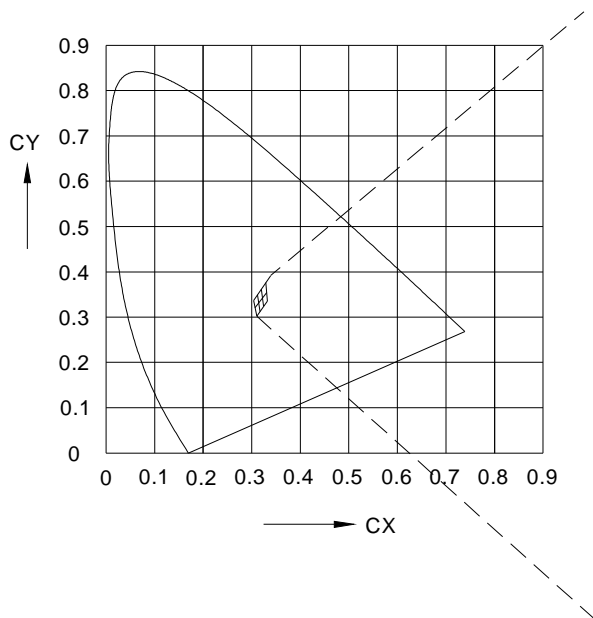

**Chromaticity Coordinates Specifications for Bin Grading:**

COLOR RANKS (.Ta=25°C)

**WARM WHITE**

BIN	RANK				
7A	X	0.4147	0.4221	0.4342	0.4259
	Y	0.3814	0.3984	0.4028	0.3853
7B	X	0.4221	0.4299	0.4430	0.4342
	Y	0.3984	0.4165	0.4212	0.4028
7C	X	0.4342	0.4430	0.4562	0.4465
	Y	0.4028	0.4212	0.4260	0.4071
7D	X	0.4259	0.4342	0.4465	0.4373
	Y	0.3853	0.4028	0.4071	0.3893

Note: X,Y Tolerance each Bin limit is  $\pm 0.01$ .

**Chromaticity Coordinates & Bin grading diagram:**

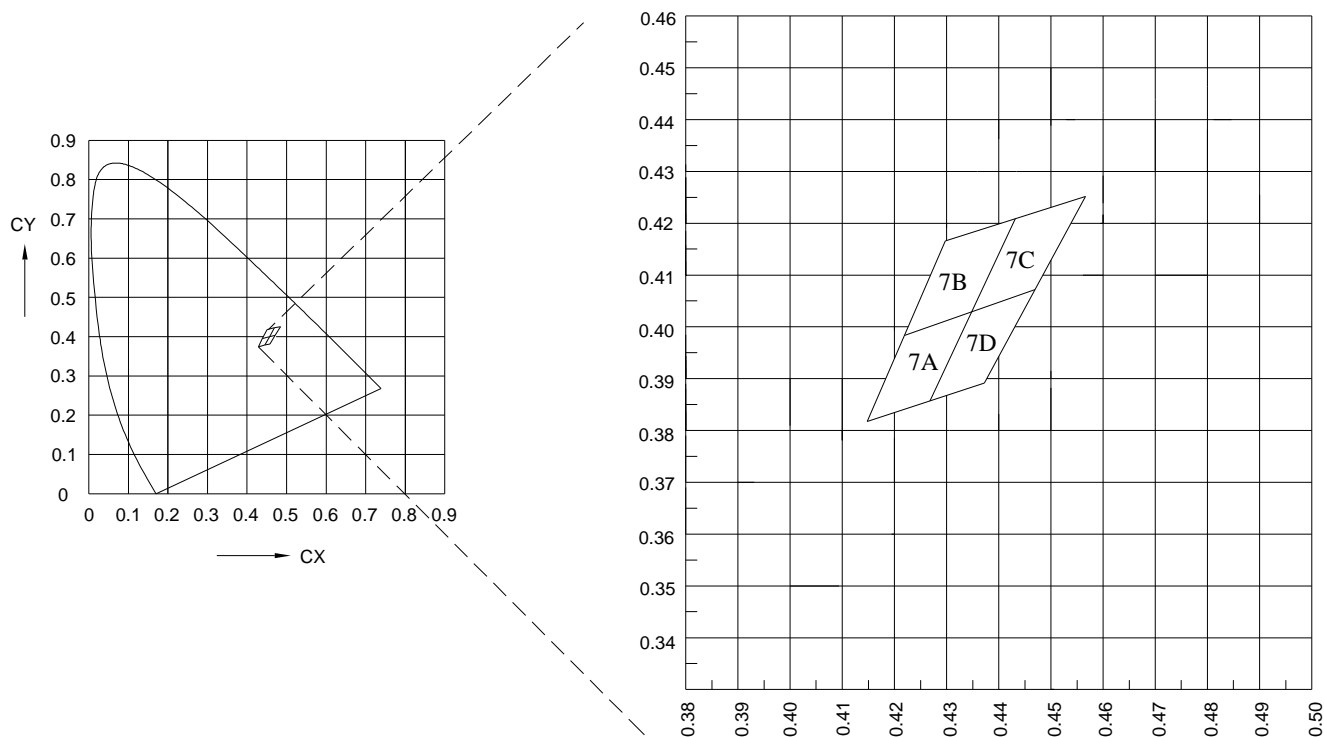

## Handling Indications

During processing, mechanical stress on the surface should be minimized as much as possible. Sharp objects of all types should not be used to pierce the sealing compound

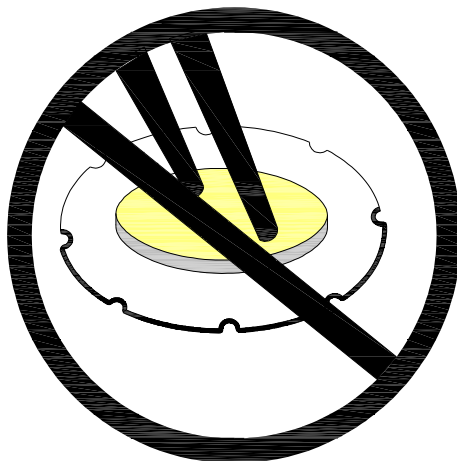

Figure 1

In general, LEDs should only be handled from the side. By the way, this also applies to LEDs without a silicone sealant, since the surface can also become scratched.

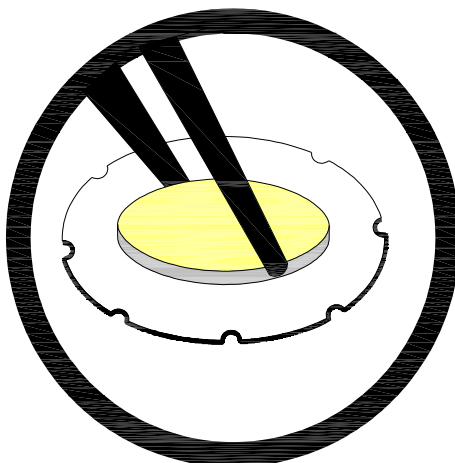

Figure 2

When populating boards in SMT production, there are basically no restrictions regarding the form of the pick and place nozzle, except that mechanical pressure on the surface of the resin must be prevented.

This is assured by choosing a pick and place nozzle which is larger than the LED's reflector area.

**Tray packaging**

