



LEDTECH ELECTRONICS CORP.

NANYA ROAD, MUGANG ZHAOQING
CITY GUANGDONG CHINA.

TEL: 86-758-2875541, 2870651, 2877464, 2876185, 2877017

FAX: 86-758-2878014

[Http://www.ledtech.com.tw](http://www.ledtech.com.tw)

SPECIFICATION

PART NO. : LP30NR-S036

COB 28.4 x 25mm TYPE



Approved by	Checked by	Prepared by
王方波	蘇智良	顏保宏

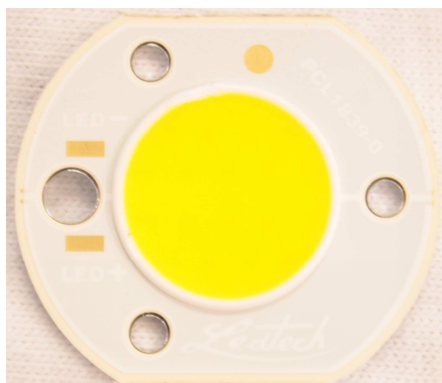

Features

- Pb-Free soldering application
- RoHS compliance
- Multi-Chip package
- High Reliability

Application

- Bulb
- Indoor decoration lighting
- Signal and symbol luminaries
- Reading lights
- Portable flashlight

Package Dimensions

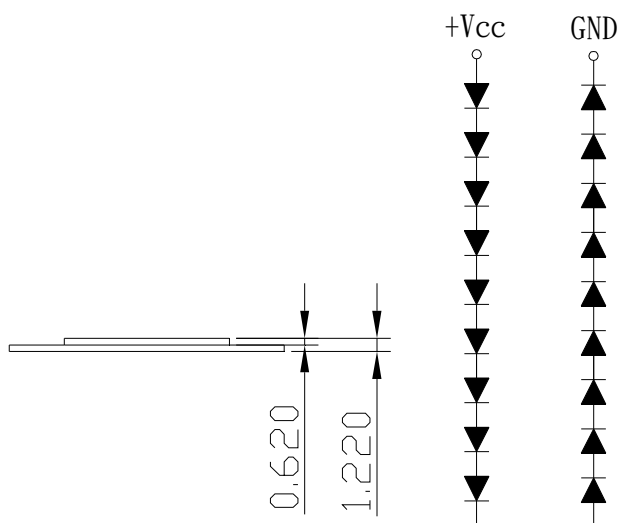
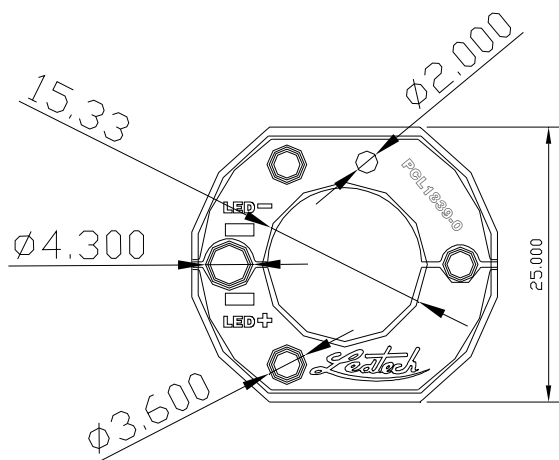

Notes:

1. All dimensions are in mm.
2. Tolerance is ± 0.25 mm unless otherwise noted.

Description

Part No.	LED Chip		Lens Color
	Material	Emitting Color	
LP30NR-S036	InGaN/ Sapphire	Warm White	Orange Diffused

Absolute Maximum Ratings at Ta=25 °C

Parameter	Symbol	Rating	Unit
Power Dissipation	P _D	3.9	W
Reverse Voltage ★	V _R	5	V
D.C. Forward Current	I _f	60	mA
Peak Current(1/10Duty Cycle,0.1ms Pulse Width.)	I _f (Peak)	100	mA
Operating Temperature Range	T _{opr.}	-40 to +100	°C
Storage Temperature Range	T _{stg.}	-40 to +100	°C
Solder Heat Resistance	SHR	Hand Soldering:300±5°C for 3 sec.	
Electric Static Discharge Threshold (HBM)	ESD	1000	V

★ The value are based on 1 die performance.

Electrical and Optical Characteristics :

Parameter	Symbol	Condition	Values			Units	
			Min.	Typ.	Max.		
Luminous Flux	Φ _v	IF=60mA		350		lm	
			Rank L1	200	--		300
			Rank L2	300	--		400
			Rank L3	400	--		500
Forward voltage	V _F	IF=60mA		56		V	
			Rank V1	50	--		55
			Rank V2	55	--		60
			Rank V3	60	--		65
Correlated Colour Temperature	CCT	IF=60mA	2585	--	2875	K	
CIE Chromaticity Coordinates: X Axis	X	IF=60mA	--	0.4578	--		
CIE Chromaticity Coordinates: Y Axis	Y	IF=60mA	--	0.4101	--		
Reverse Current	I _R	V _r =5V	--	--	50	μA	
Color Renderig Index	CRI	IF=60mA	--	80	--	Ra	
Viewing angle at 50% IV		2θ1/2	--	120	--	Deg.	

Notes:

1. The datas tested by IS tester.
2. Customer's special requirements are also welcome.

Chromaticity Coordinates Specifications for Bin Grading:

COLOR RANKS (IF=20mA.Ta=25°C)

BIN	RANK				
8A	X	0.4345	0.4430	0.4582	0.4483
	Y	0.3880	0.4055	0.4099	0.3919
8B	X	0.4430	0.4530	0.4687	0.4582
	Y	0.4055	0.4248	0.4289	0.4099
8C	X	0.4582	0.4687	0.4813	0.4700
	Y	0.4099	0.4289	0.4319	0.4126
8D	X	0.4483	0.4582	0.4700	0.4593
	Y	0.3919	0.4099	0.4126	0.3944

Note: X,Y Tolerance each Bin limit is±0.01.

Chromaticity Coordinates & Bin grading diagram:

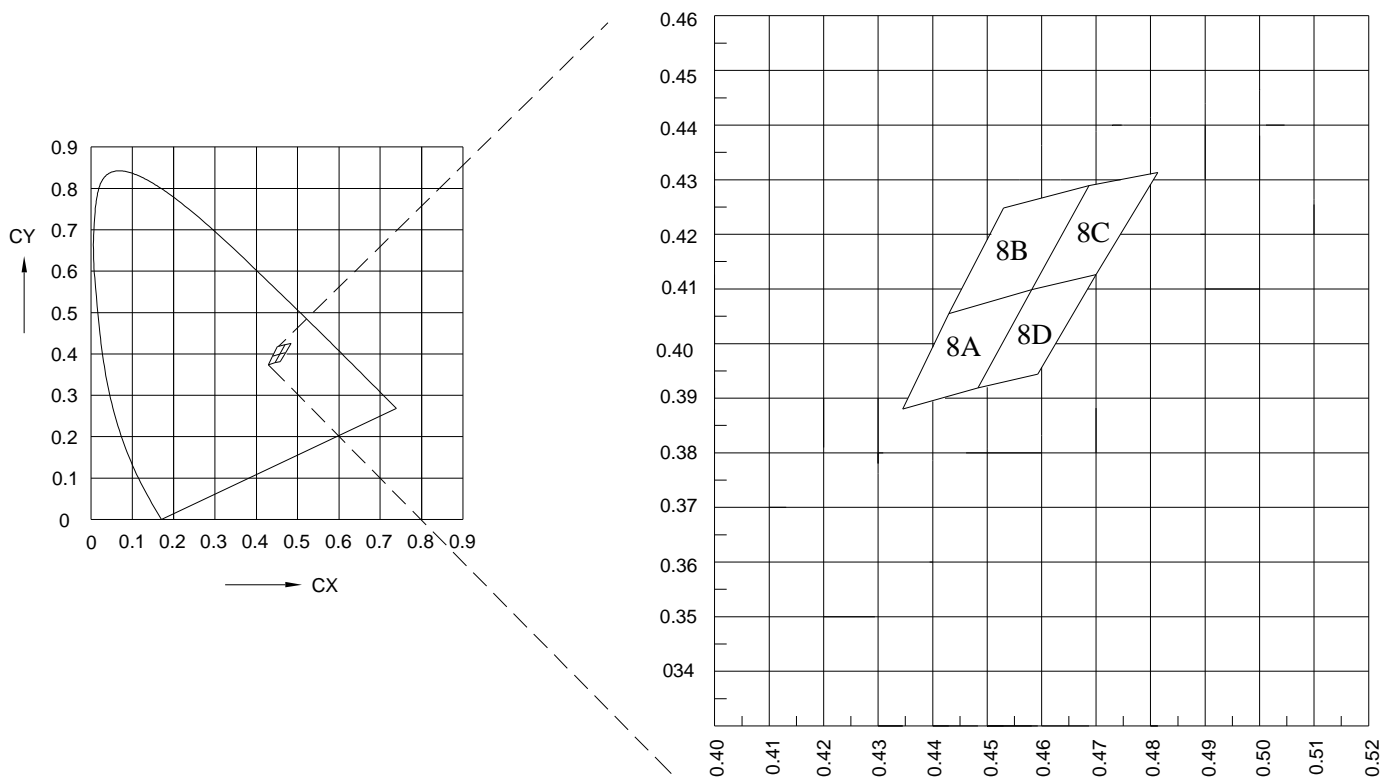

Typical Electrical/Optical Characteristic Curves

(25°C Ambient Temperature Unless Otherwise Noted)

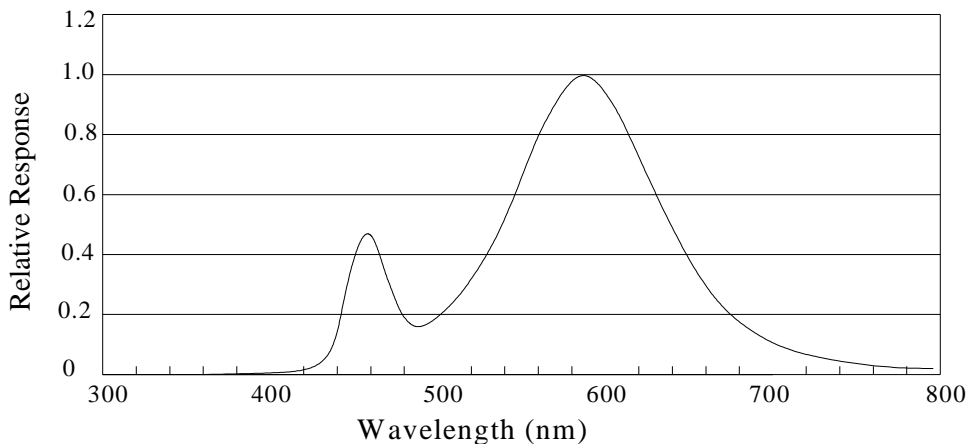
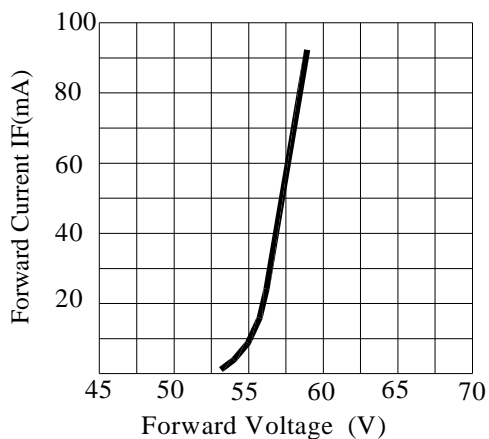
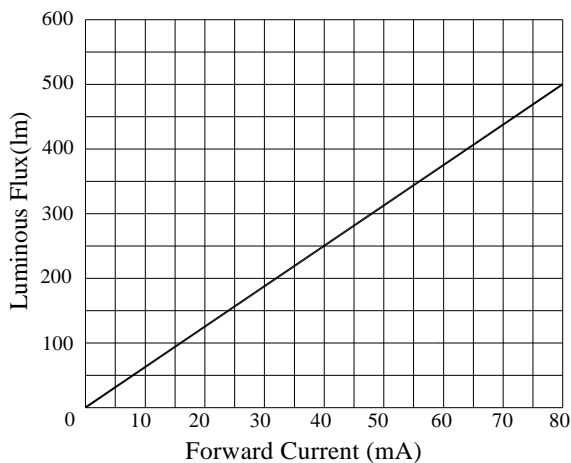

Fig.1 WHITE LED Spectrum VS. WAVELENGTH



Forward Current VS. Applied Voltage



Forward Current VS. Luminous Intensity

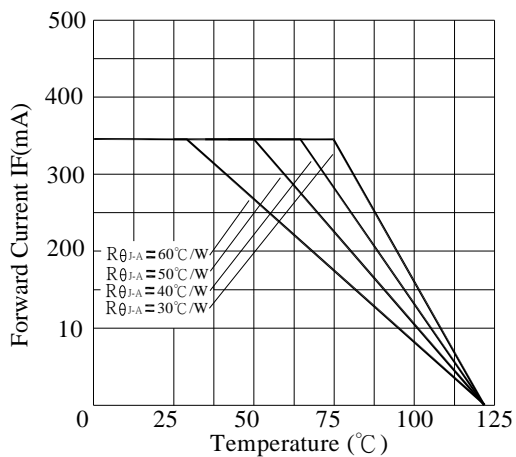

Ambient Temperature VS. Forward Current

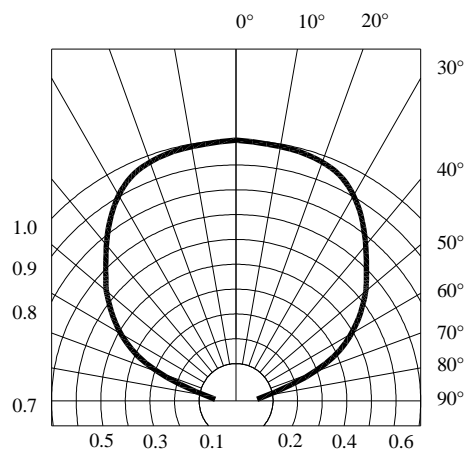

Radiation Diagram

Handling of Silicone Resin LEDs

Handling Indications

During processing, mechanical stress on the surface should be minimized as much as possible. Sharp objects of all types should not be used to pierce the sealing compound

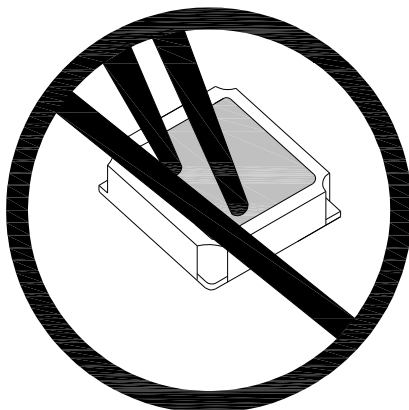

Figure 1

In general, LEDs should only be handled from the side. By the way, this also applies to LEDs without a silicone sealant, since the surface can also become scratched.

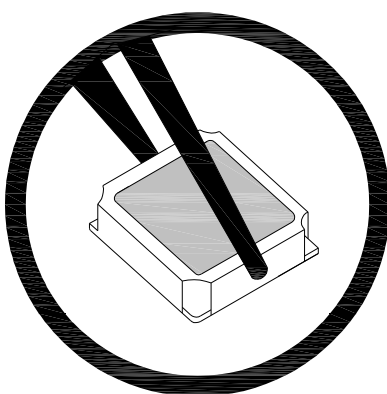

Figure 2

When populating boards in SMT production, there are basically no restrictions regarding the form of the pick and place nozzle, except that mechanical pressure on the surface of the resin must be prevented. This is assured by choosing a pick and place nozzle which is larger than the LED's reflector area.