



LEDTECH ELECTRONICS CORP.

NANYA ROAD, MUGANG ZHAOQING
CITY GUANGDONG CHINA.

TEL: 86-758-2875541, 2870651, 2877464, 2876185, 2877017

FAX: 86-758-2878014

[Http://www.ledtech.com.tw](http://www.ledtech.com.tw)

SPECIFICATION

PART NO. : LP3HG3-ST-UCR3-S16

1W HIGH POWER LED



Approved by

Checked by

Prepared by

Fang-Po

Chih_liang

Carlos-Chen

Package Dimensions

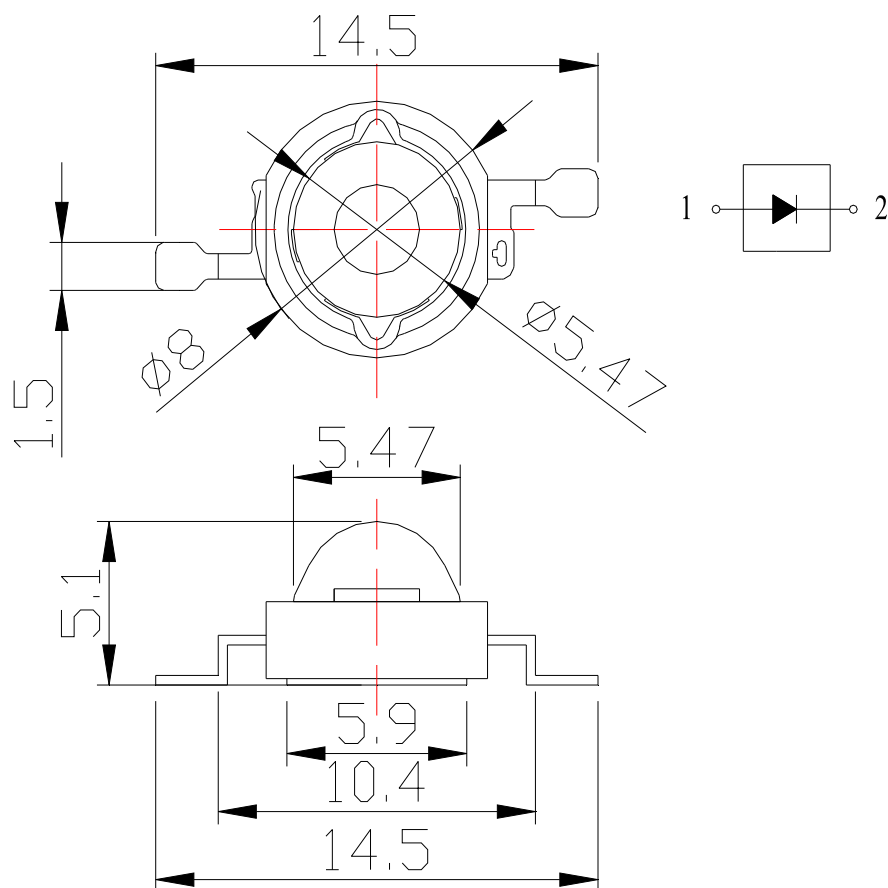

Notes:

1. All dimensions are in mm.
2. Tolerance is +/-0.6mm unless otherwise noted.

Description

Part NO.	LED Chip		Lens Color
	Material	Color Coordinates	
LP3HG3-ST-UCR3-S16	InGaN/Al2O3	True Green	Water Clear

Absolute Maximum Ratings at Ta=25°C :

Parameter	Rating	Unit
Power Dissipation	1365	mW
LED Junction Temperature	120	°C
Reverse Voltage	5	V
D.C. Forward Current	350	mA
Pulsed Forward Current ; $t_p \leq 100\mu\text{s}$, Duty cycle=0.005)*1	700	mA
Operating Temperature Range	-40 to +75	°C
Storage Temperature Range	-40 to +100	°C
Soldering Temperature	Reflow Soldering: 260°C for 10 sec. Hand Soldering: 350°C for 3 sec.	
Electric Static Discharge Threshold (HBM)	6000	V

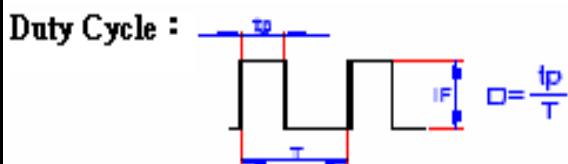
**Notes:**

- 1、 Proper current derating must be observed to maintain junction temperature below the maximum .
- 2、 All products not sensitive to ESD damage(6000 Volts by HBM condition).
- 3、 Be careful with a powered up current limited power supply, because of current spikes during power up and/or connection. Best practice is to connect the LED then turn up the voltage gradually. People building their own power supplies should design for minimum current spikes during power up and connection.
- 4、 For best results the customer needs to provide proper control of the thermal path ,protect against electrical overstress conditions, and ensure that Ledtech emitters are properly attached to the mcpcb/heat sink.
- 5、 It is strongly recommended that the temperature of lead does not exceed 55°C.
- 6、 It is strongly recommended to apply on electrically isolated heat conducting film between the slug and contact surfaces.

Electrical and Optical Characteristics :

Parameter		Symbol	Condition	Values			Units
				Min.	Typ.	Max.	
Luminous Flux	FULL	Φ_v	IF=350mA		84		lm
	Rank L1			80	90		
	Rank L2			90	100		
Forward voltage	Rank V1	VF	IF=350mA	2.9	--	3.1	V
	Rank V2			3.1	--	3.3	
	Rank V3			3.3	--	3.5	
	Rank V4			3.5	--	3.7	
	Rank V5			3.7		3.9	
Dominant Wavelength		λ_d	IF=350mA	515		520	nm
				520		525	
				525		530	
				530		535	
Reverse Current		I_R	$V_r = 5 V$	--	--	50	μA
Viewing angle at 50% IV		$2\theta_{1/2}$	IF=350mA	--	130	--	Deg.
Thermal Resistance Junction to Case		$R\theta_{J-C}$	IF=350mA	--	15	--	$^{\circ}C/W$

Notes :

1. The datas tested by IS tester.
2. Customer's special requirements are also welcome.

Typical Electrical/Optical Characteristic Curves

(25°C Ambient Temperature Unless Otherwise Noted)

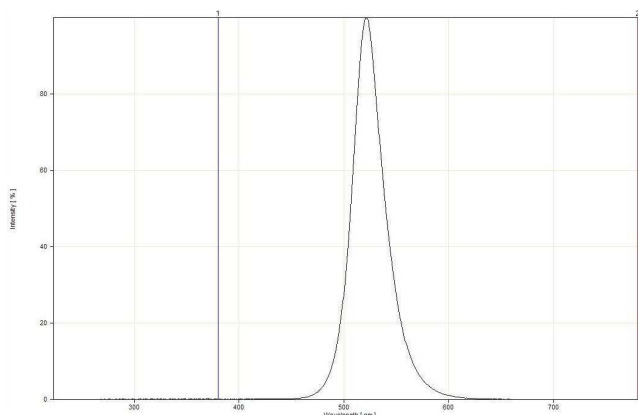
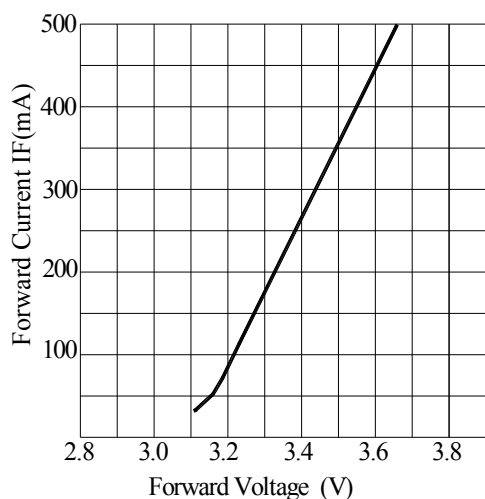
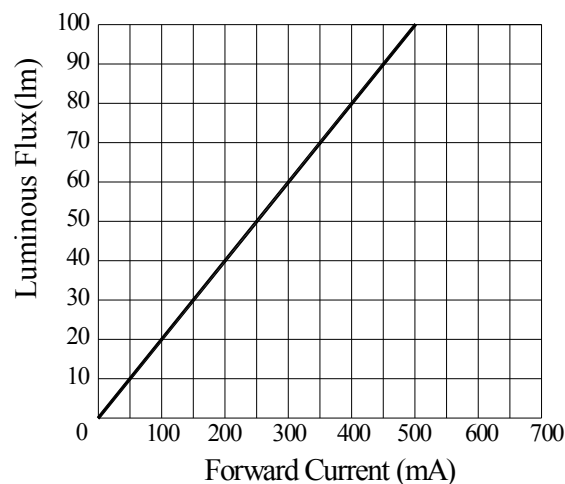

Fig.1 WHITE LED Spectrum VS. WAVELENGTH



Forward Current VS. Applied Voltage



Forward Current VS. Luminous Flux

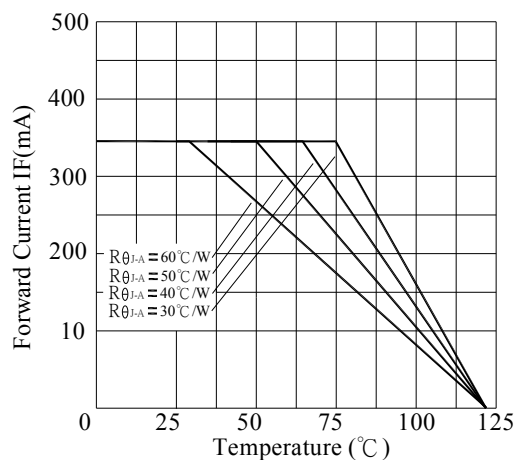

Ambient Temperature VS. Forward Current

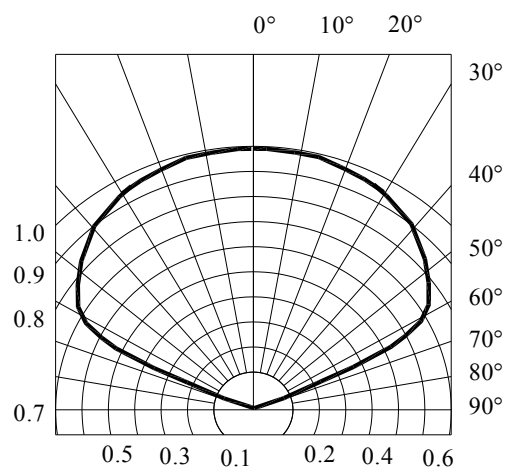

Radiation Diagram

PRECAUTION IN USE

Storage

Recommended storage environment

Temperature: 5°C ~ 30°C (41°F ~ 86°F)

Humidity: 60% RH Max.

Moisture measures: Please refer to Moisture-sensitive label on reels package bags.

If unused LEDs remain, they should be stored in moisture proof packages, such as sealed container with packages of moisture absorbent material (silica gel). It is also recommended to return the LEDs to the original moisture proof bag and to reseal the moisture proof bag again.

Fold the opened bag firmly and keep in dry environment.

Soldering

	Reflow Soldering		Hand Soldering	
	Lead Solder	Lead – free Solder		
Pre-heat	120~150°C	180~200°C	Temperature	350°C Max.
Pre-heat time	120sec. Max.	120sec. Max.	Soldering time	3sec. Max. (one time only)
Peak temperature	240°C Max.	260°C Max.		
Soldering time	10sec. Max.	10sec. Max.		
Condition	refer to Temperature- profile 1	refer to Temperature- profile 2		

*After reflow soldering rapid cooling should be avoided.

[Temperature-profile (Surface of circuit board)]

Use the conditions shown to the under figure.

< 1 : Lead Solder >

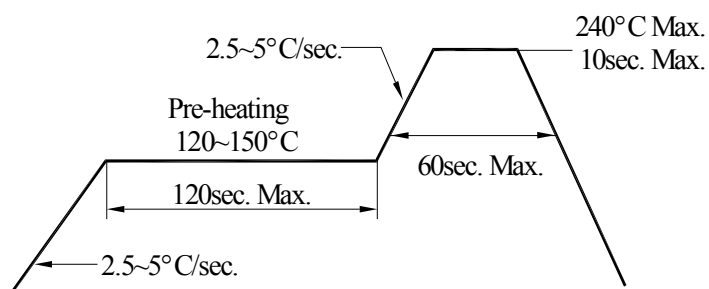

< 2 : Lead-free Solder >

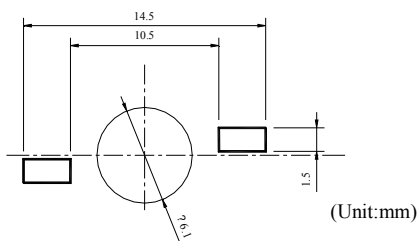
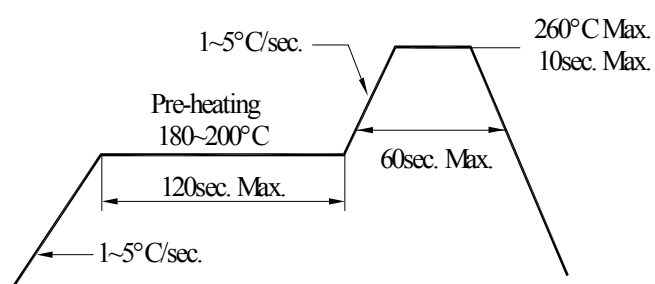

Handling of Silicone Resin LEDs

Handling Indications

During processing, mechanical stress on the surface should be minimized as much as possible. Sharp objects of all types should not be used to pierce the sealing compound

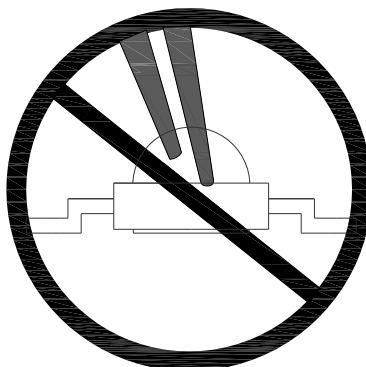

Figure 1

In general, LEDs should only be handled from the side. By the way, this also applies to LEDs without a silicone sealant, since the surface can also become scratched.

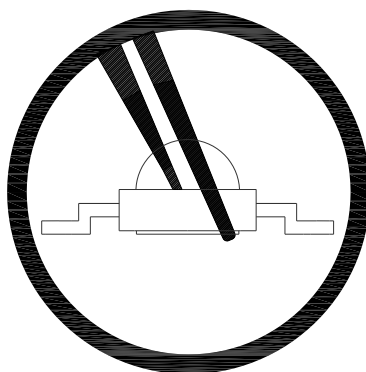

Figure 2

When populating boards in SMT production, there are basically no restrictions regarding the form of the pick and place nozzle, except that mechanical pressure on the surface of the resin must be prevented.

This is assured by choosing a pick and place nozzle which is larger than the LED's reflector area.

ENCASED TYPE

TUBE:
QUANTITY: 50 PCS

PART NO :LTXXXX-XX
LOT :XXXXXXXX QTY'S :XXPCS BIN CODE:XX-XX

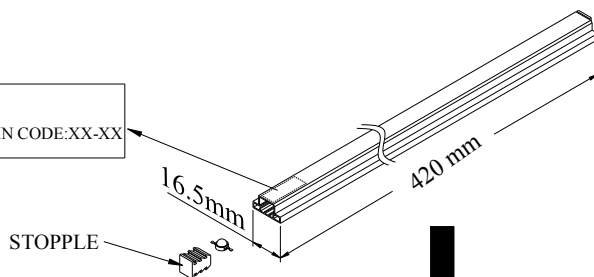

INNER BOX
QUANTITY: 10 TUBES
TOTAL: 5,00 PCS

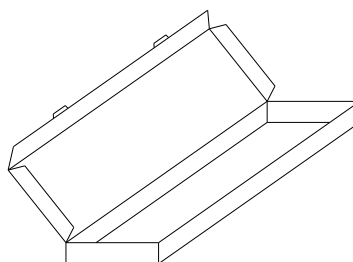

MIDDLE BOX
QUANTITY: 10 BOXES
TOTAL: 5,000 PCS

PART NO.	LXXXXX-XX-XX				
LOT NO.	XXXXXXXXXX				
BIN CODE	Xx X	Xx X	Xx X	Xx X	TOTAL
QUANTITY	PCS	PCS	PCS	PCS	PCS
DATE	XXXX, XX, XX				

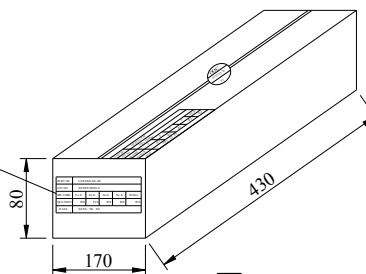

OUTER CARTON
QUANTITY: 2 BOXES
TOTAL: 10,000 PCS

C/T NO. 箱 號	XX
PART NO. 料 號	LXXXXX-XX-XX
QUANTITY 數 量	PCS
N.W. 淨 重	KGS
G.W. 毛 重	KGS
REMARK 備 註	

